



Government of Nepal
Ministry of Physical Infrastructure and Transport
Department of Roads
Planning and Design Branch

Standard Drawings for Road Elements

Published by:
Planning and Design Branch
Department of Roads
February 2014

FOREWORD

The Standard Drawings for Road Elements has been prepared keeping in mind the similarity and simplicity of road structures being constructed by Department of Roads. These structures are only for the thumb rule and a separate design is necessary for a specific site condition.

It is hoped that these drawings will guide the engineers in their practical field and save time for designing simple structures.

Any comments, suggestions and corrections are most welcome. We appreciate written comments with justifications. Those comments shall be incorporated in its next revision.

Department of Roads

Members of the Committee:

- | | |
|------------------------------|----------------------------|
| 1. Arjun Jung Thapa | Deputy Director General |
| 2. Purna Siddhi Lal Shrestha | Superintendent Engineer |
| 3. Saroj Kumar Pradhan | Superintendent Engineer |
| 4. Saroj Bhattarai | Senior Divisional Engineer |
| 5. Naresh Man Shakya | Senior Divisional Engineer |
| 6. Rajesh Kumar Yadav | Senior Divisional Engineer |

Table of Contents

S.N.	Drawing Name	D. No.	Page No
1	Cover Page		1
2	Foreword		2
3	Table of Contents		3
4	General Notes for Culverts		4
5	Typical Plan and Profile	1	5
6	Typical Cross Sections	2	6
7	Miscellaneous Geometric Details : Curve	3	7
8	Miscellaneous Geometric Details : Road intersection	4	8
9	Geometric Details : Hairpin Bends	5	9
10	Bus bay and Passing Zone	6	10
11	Benchmark and ROW Monument	7	11
12	Delineators Spacing	8	12
13	Typical Petrol pump Station for Plains	9	13
14	Typical Side Drains	10	14
15	Precast RCC Side Drains	11	15
16	Kilometer Post	12	16
17	Road Safety Barrier	13	17
18	Gabion Barrier and Delineator Post	14	18
19	Land slide stabilization	15	19
20	Rip Rap Aprons and Chute Details	16	20
21	Gabion Retaining Walls	17	21
22	Stone Masonry Retaining Wall	18	22
23	Dry and Composite Masonry Retaining Walls	19	23
24	Revetments and Breast Walls	20	24
25	RCC Cantilever Wall	21	25
26	Crib Walls	22	26
27	Pipe Culvert for Plain area	23	27
28	Pipe Culvert for Hilly Area	24	28
29	Pipe Culvert for Plain and Hilly Area	25	29
30	Slab Culvert (No Fill): General Details	26	30
31	Slab Culvert (No Fill): Brick Masonry Abutments	27	31

Table of Contents

S.N.	Drawing Name	D. No.	Page No
32	Slab Culvert (No Fill): Reinforcement Details	28	32
33	Slab Culvert (With Fill): General Details	29	33
34	Slab Culvert (With Fill): Reinforcement Details	30	34
35	Slab Culvert : Double and Triple Cell General Details	31	35
36	Slab Culvert : Double and Triple Cell Reinforcement Details	32	36
37	Box Culvert Single Cell Without EC: Typical Drawing	33	37
38	Box Culvert Single Cell Without EC: Reinforcement Details	34	38
39	Box Culvert Single Cell Without EC: Bar Schedule	35	39
40	Box Culvert Single Cell With 3m EC: Typical Drawing	36	40
41	Box Culvert Single Cell With 3m EC: Reinforcement Details	37	41
42	Box Culvert Single Cell With 3m EC: Bar Schedule	38	42
43	Box Culvert Double Cell Without EC: Typical Drawing	39	43
44	Box Culvert Double Cell Without EC: Reinforcement Details	40	44
45	Box Culvert Double Cell Without EC: Bar Schedule	41	45
46	Box Culvert Double Cell With 3m EC: General Details	42	46
47	Box Culvert Double Cell With 3m EC: Reinforcement Details	43	47
48	Box Culvert Double Cell With 3m EC: Bar Schedule	44	48
49	Box Culvert Triple Cell Without EC: General Details	45	49
50	Box Culvert Triple Cell Without EC: Reinforcement Details	46	50
51	Box Culvert Triple Cell Without EC: Bar Schedule	47	51
52	Wing wall for Box culvert General Details	48	52
52	Wing wall for Box culvert Reinforcement Details	49	53
53	Overhead Traffic Sign Plan	50	54
54	Overhead Traffic Sign Front View	51	55
55	Overhead Traffic Sign Girder Details	52	56
56	Overhead Traffic Sign Section Details	53	57
57	Overhead Traffic Sign Additional Details	54	58
58	Road Traffic Sign-1	55	59
59	Road Traffic Sign-2	56	60

GENERAL NOTES FOR CULVERTS

1. These notes are applicable for the Standard Drawings for R.C.C culverts with and without footpaths.
2. These drawings are applicable only for slab culverts and slab bridges for single lane as well as double lane traffic.
3. All dimensions are in millimeters unless otherwise mentioned. Only written dimensions are to be followed. No drawing shall be scaled.
4. Design criteria:
The design is according to the following codes:
a) NRS : 2027 (Second Revision 2070)

The following loads have been considered in the design:
a) Design load NRS 2027 (Second Revision 2070)
b) Wearing coat load of 2 KN/sq.m.

The designs are applicable for 'MODERATE' conditions of exposure.
5. Wearing coat shall consist of the following:
50 mm thick at the end and 100 mm thick at the middle Confirming to clause 3104 of standard specifications for Road and Bridge works.
6. 20 mm expansion joint does not cater for any allowance for possible tilting of abutment.
7. Support for the deck shall provide a bearing width of 400 mm.

MATERIALS SPECIFICATIONS

Concrete

1. Concrete shall be of nominal mix and shall have minimum 28 days characteristic strength on 150 mm cubes for all elements of superstructure as indicated below.

Conditions of exposure	Concrete grade	Characteristic Strength
MODERATE	M25	25 N/mm ²

High strength ordinary Portland cement conforming to IS: 8112 or ordinary Portland cement conforming to IS 269

capable of achieving the required design concrete strength shall only be used.

2. The minimum cement content and maximum water cement ratio in the concrete design mix shall be 310 kg/cum and 0.45 respectively for 'MODERATE' conditions of exposure.

Reinforcement

All reinforcing bars shall be High Yield Strength Deformed bars (Grade designation Fe 415) conforming to Nepal Standard (NS).

Water

Water to be used in concreting and curing shall conform to Clause 302.4 of IRC 21 - 1987.

WORKMANSHIP/ DETAILING

1. Minimum clear cover to any reinforcement including stirrups shall be 50 mm unless shown otherwise in the drawings.
2. For ensuring proper cover of concrete to reinforcement bars specially made polymer cover blocks shall only be used.
3. Construction Joints
 - I. The location and provision of construction joints shall be approved by Engineer-in-charge. The concreting operation shall be carried out continuously upto the construction joint.
 - II. The concrete surface at the joint shall be brushed with a stiff brush after casting while the concrete is still fresh and it has only slightly hardened.
 - III. Before new concrete is poured the surface of old concrete shall be prepared as under:
 - a) For hardened concrete, the surface shall be thoroughly cleaned to remove debris/laitance and made rough so that 1/4 of the size of the aggregate or structurally damaging the concrete.
 - b) For partially hardened concrete, the surface shall be treated by wire brush followed by an air jet.

- c) The old surface shall be soaked with water without leaving puddles immediately before starting concreting to prevent the absorption of water from new concrete.

IV. New concrete shall be thoroughly compacted in the region of the joint.

4. Welding of reinforcement bars shall not be permitted.

5. Laps in reinforcement:

- i) Minimum lap length of reinforcement shall be kept as 83ϕ where ' ϕ ' is the diameter of bar.
- ii) Not more than 50% of reinforcement shall be lapped at any one location.

6. Bending of reinforcement bars shall be as per IS: 2502.

7. Supporting chairs of 12 mm diameter shall be provided at suitable intervals as per IS: 2502

8. Concrete shall be produced in a mechanical mixer of capacity not less than 200 liters having integral weigh-batching facility and automatic water measuring and dispensing device.

9. Proper compaction of concrete shall be ensured by use of full width screed vibrators for concrete in deck slab.

10. Properly braced steel plates shall be used as shuttering.

11. Sharp edges of concrete shall be chamfered.

GENERAL SPECIFICATIONS

The work shall be executed in accordance with standard specifications for Road and Bridge Works (Ministry of physical planning and works, Department of Roads, July 2001).

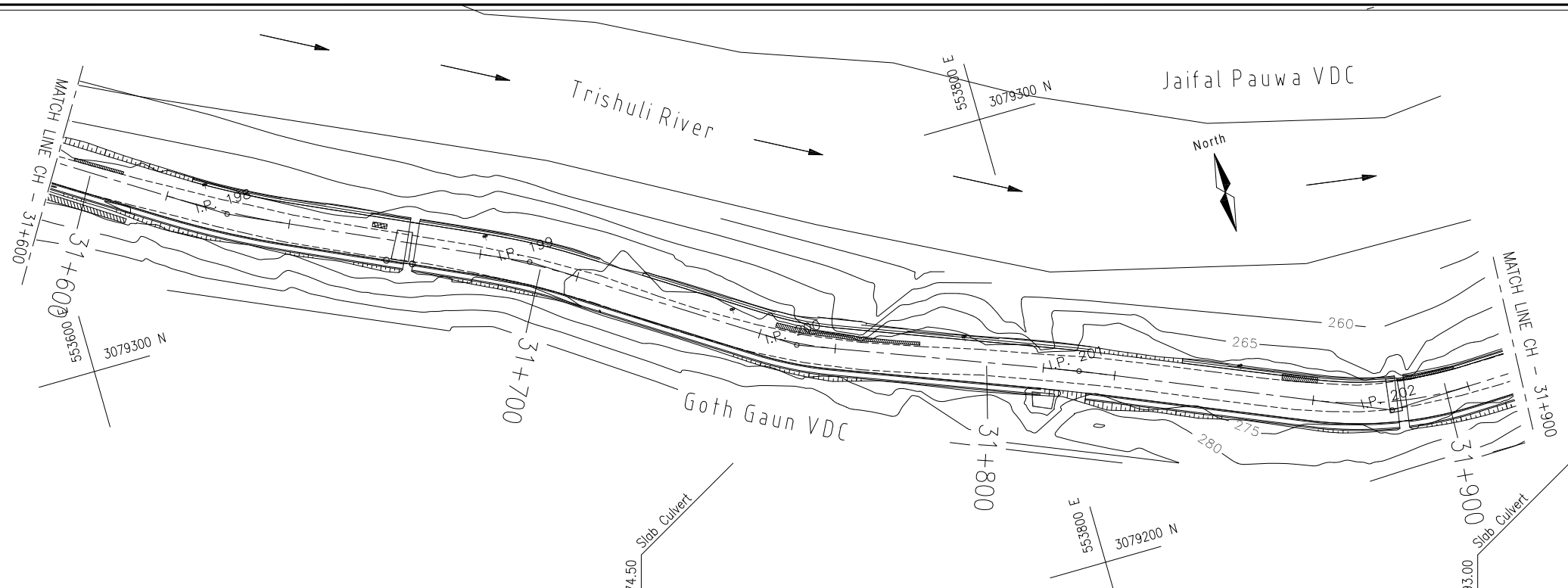

IP NO.	COORDINATES		DIS (M)	DEF. ANGLE Deg	RADIUS M	CURVE DATA		
	EASTING	NORTHING				T	E	Lc
198	553637.13	3079325.00	54.14	7.82	200	13.67	0.47	27.30
199	553697.50	3079297.00	66.55	8.29	150	10.86	0.39	21.69
200	553748.38	3079263.75	60.78	11.99	80	8.40	0.44	16.74
201	553805.81	3079241.50	61.60	1.79	500	7.80	0.06	15.60
202	553868.94	3079214.75	68.56	24.44	80	17.32	1.85	34.12

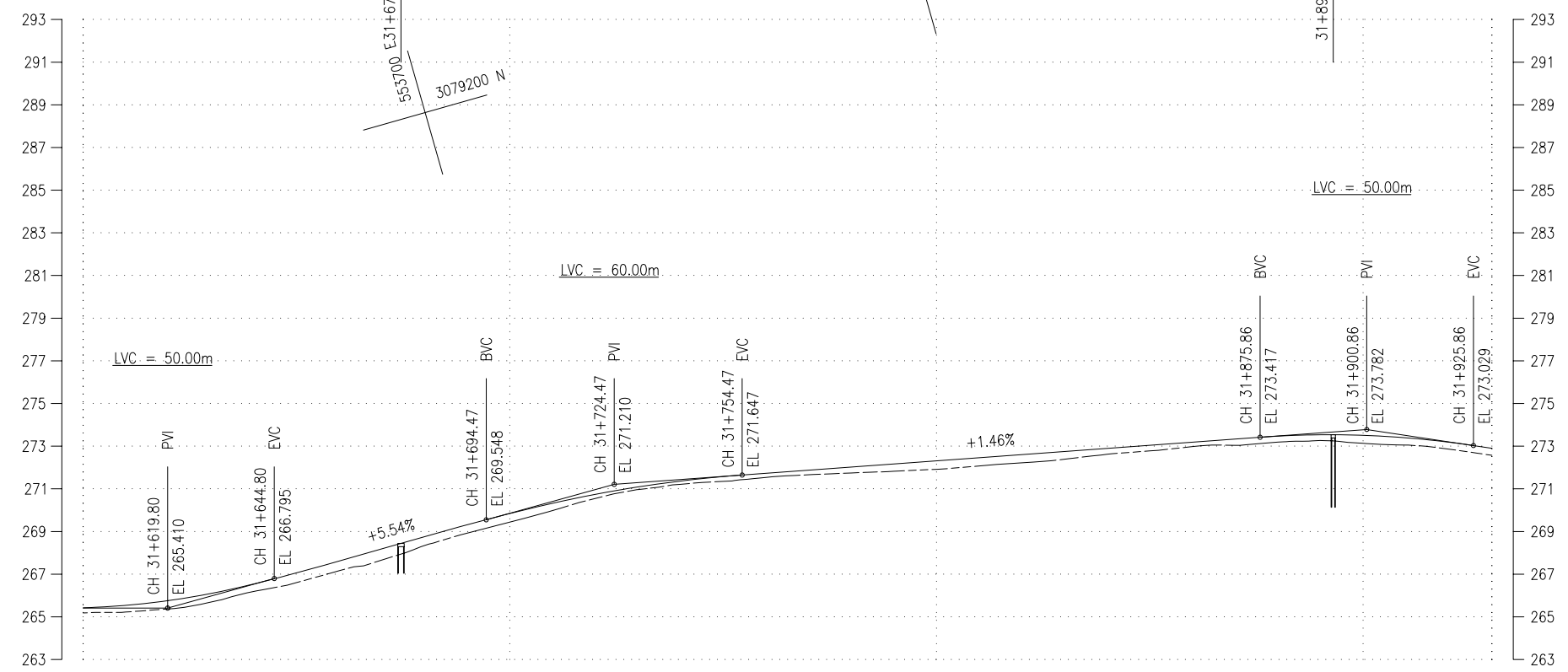

DESIGN LEVEL (m)	265.425	265.762	266.542	267.638	268.746	269.844	270.741	271.365	271.728	272.020	272.311	272.603	272.895	273.186	273.470	273.509	273.190
EXISTING LEVEL (m)	265.182	265.374	266.189	267.160	268.337	269.435	270.548	271.214	271.533	271.743	271.916	272.220	272.619	272.979	273.188	273.135	272.865
CHAINAGE (km)	31+600.00	31+620.00	31+640.00	31+660.00	31+680.00	31+700.00	31+720.00	31+740.00	31+760.00	31+780.00	31+800.00	31+820.00	31+840.00	31+860.00	31+880.00	31+900.00	31+920.00
HORIZONTAL ALIGNMENT	RIGHT: IP-193 (R=150.00), IP-195 (R=500.00) LEFT: IP-192 (R=200.00), IP-194 (R=80.00), IP-196 (R=80.00)																
SUPER ELEVATION	+602.53	T	+629.53	+638.83	T	+698.85	+702.54	T	+760.79	+762.05	T	+821.78	+824.18	T	+884.72	+897.84	T

Government of Nepal
 Ministry of Physical Infrastructure & Transport
 Department of Roads

STANDARD DRAWINGS FOR ROAD ELEMENTS

PLAN AND PROFILE

TYPICAL DRAWING

Signature	Recommended by	Approved by	SHEET. NO. 01
Name	Arjun Jung Thapa	Devendra Karki	
Designation	Deputy Director General	Director General	

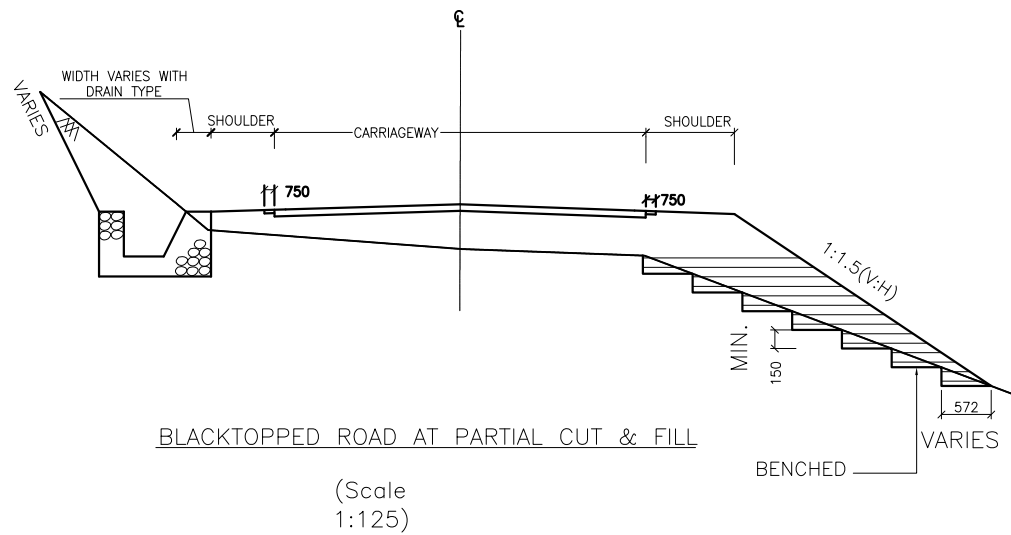

BLACKTOPPED ROAD AT PARTIAL CUT & FILL
(Scale 1:125)

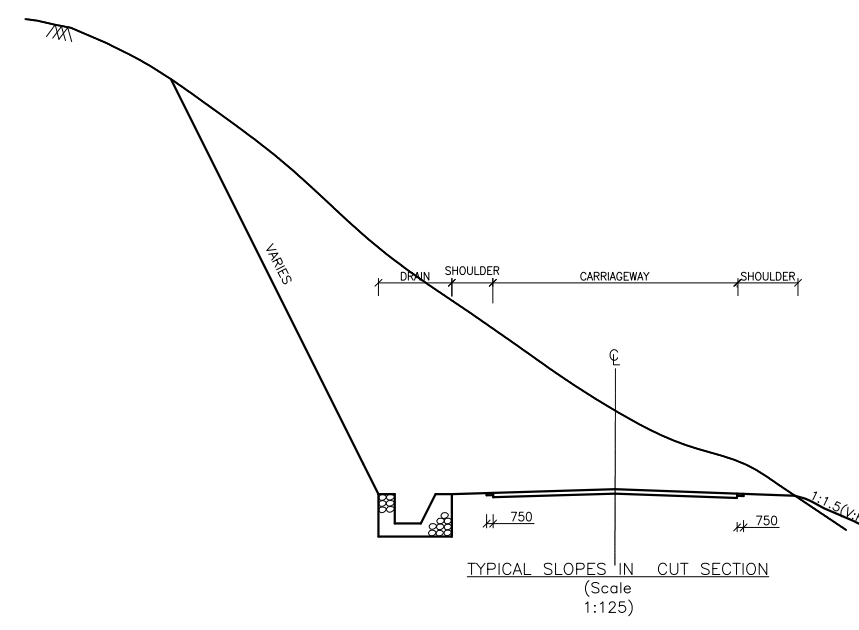

TYPICAL SLOPES IN CUT SECTION
(Scale 1:125)

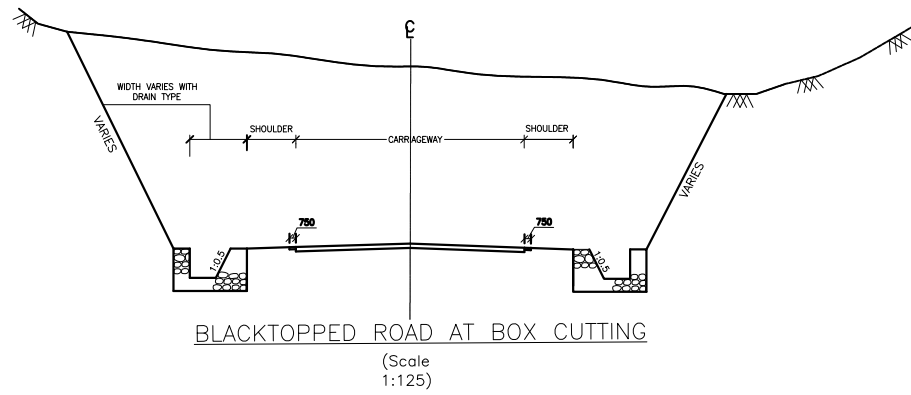

BLACKTOPPED ROAD AT BOX CUTTING
(Scale 1:125)

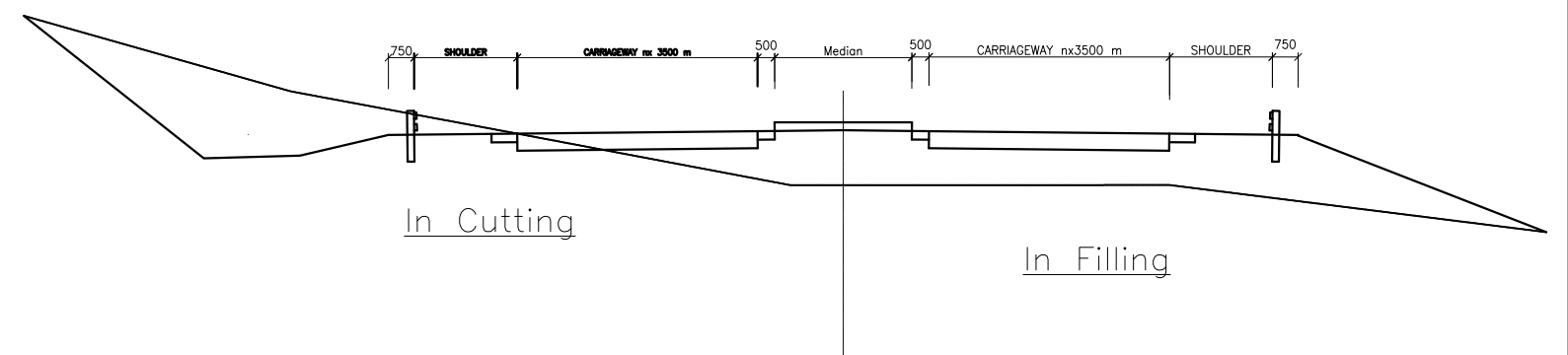

CROSS SECTION OF CLASS I ROAD
(Scale 1:500)

NOTE:

1. Cut slope shall be adjusted as per actual site condition.
2. All dimensions are in mm unless noted otherwise.
3. In plain area the embankment height should be 750 mm high above HFL for highways and 500 mm high above HFL for feeder roads.
4. Carriageway width and shoulder width shall vary according to terrain and traffic volume (i.e. single lane, intermediate lane or two lane) as per NRS.
5. The breadth of berm in high cut slopes should be minimum 1000 mm with good side drain they should be placed at height interval of 6000 - 7500 mm. But slope above the topmost berm is at least 3000 - 4000 mm.
6. In hill roads, the vertical alignment should be fixed in such a way that the cut and fill areas are nearly equal.
7. Indicated width of formation and carriageway are exclusive of extra widening at curves and passing zone/busbays.

Details of Road width as per NRS 2070

CLASS OF ROAD	CARRIAGEWAY WIDTH, M	SHOULDER WIDTH, m		MEDIAN WIDTH, m
		HARD	TOTAL	
CLASS I	7.0 + 7.0 = 14.0	0.75	1.5	3.0 TO 5.0
CLASS II	7.0	0.75	2.50	NA
CLASS III	7.0	0.75	2.00	NA
CLASS IV	3.75 OR 5.50	0.75	1.50	NA

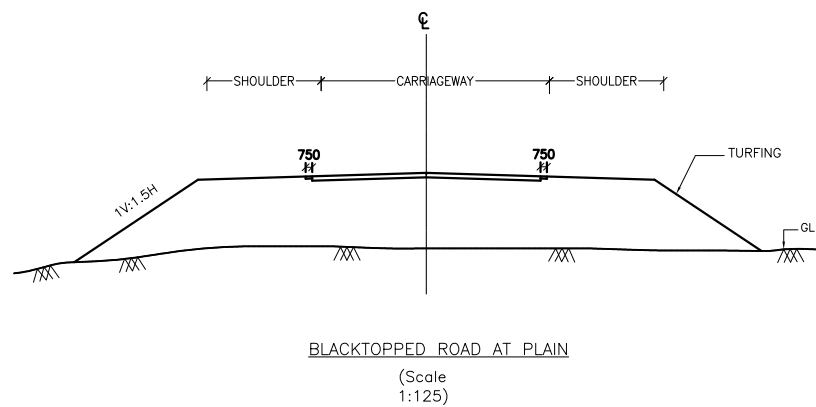

BLACKTOPPED ROAD AT PLAIN
(Scale 1:125)

Government of Nepal
Ministry of Physical Infrastructure & Transport
Department of Roads

STANDARD DRAWINGS FOR ROAD ELEMENTS

CROSS SECTIONS

TYPICAL DRAWING

	Recommended by	Approved by	SHEET. NO. 02
Signature	<i>[Signature]</i>	<i>[Signature]</i>	
	Arjun Jung Thapa	Devendra Karki	
Designation	Deputy Director General	Director General	

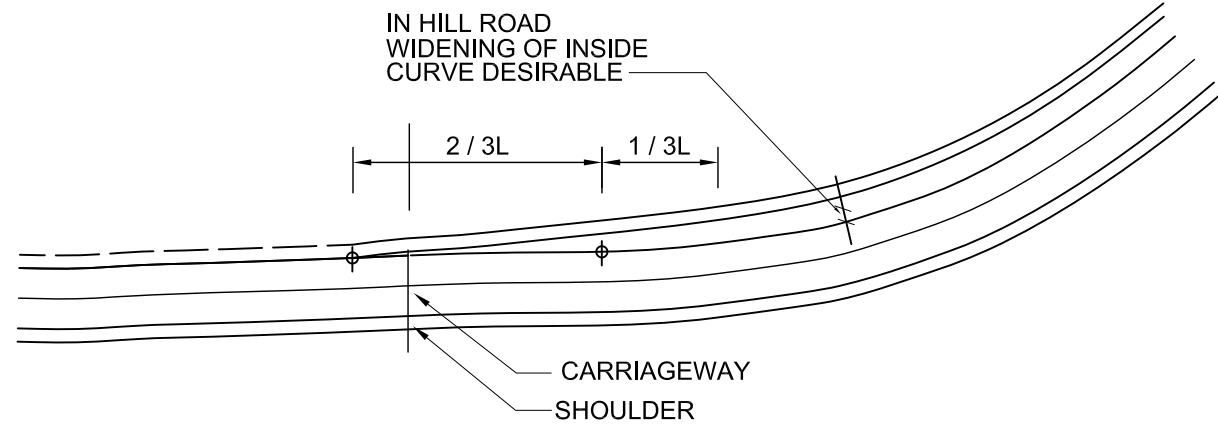

ROAD EXTRA-WIDENING

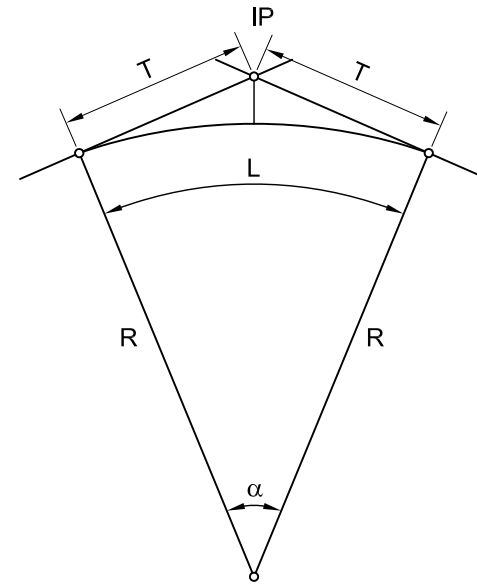

CIRCULAR CURVE FOR HORIZONTAL ALIGNMENT

- T = $R \tan \alpha$
- IP = INTERSECTION POINT
- R = RADIUS OF CIRCULAR CURVE
- T = TANGENT LENGTH
- L = LENGTH OF CIRCULAR CURVE
- T1 = BEGINNING OF CIRCULAR CURVE
- T2 = END OF CIRCULAR CURVE

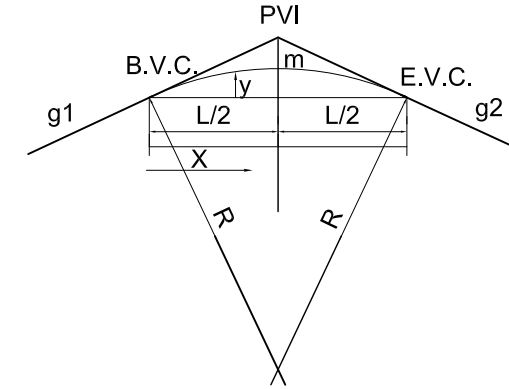

VERTICAL CURVE CALCULATION

$$y = \frac{GL}{200} \left[\frac{X}{L} \right]^2$$

- PVI = POINT OF VERTICAL INTERSECTION
- BVC = BEGINNING OF VERTICAL CURVE
- EVC = END OF VERTICAL CURVE
- G = ALGEBRAIC DIFFERENCE IN GRADES, (%)
- X = HORIZONTAL DISTANCE FROM THE START OF THE VERTICAL CURVE m.
- y = VERTICAL DISTANCE FROM THE TANGENT TO THE CURVE, m.
- g1, g2 = GRADIENT
- L = LENGTH OF CURVE

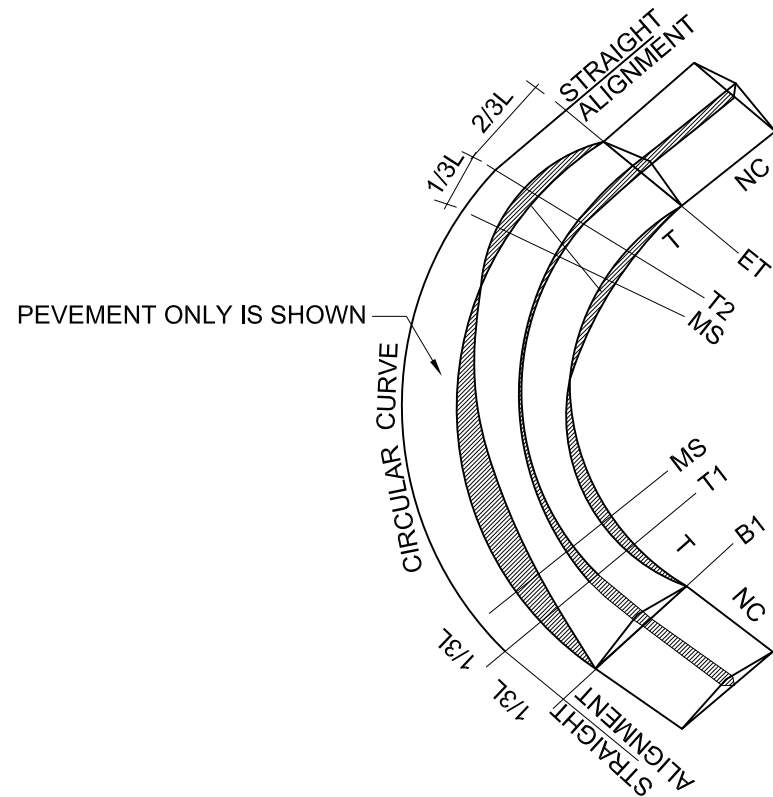

TYPICAL SUPERELEVATION

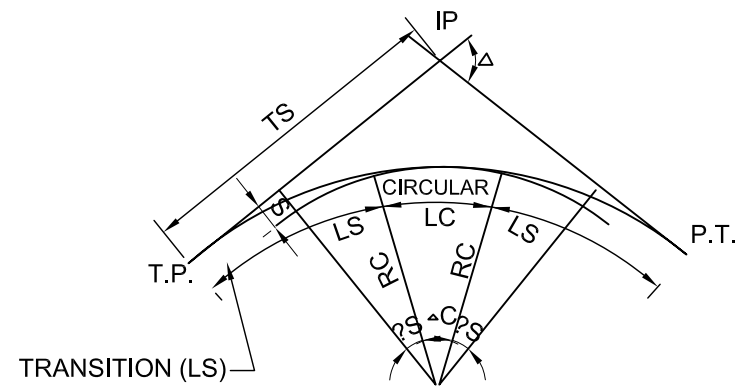

ELEMENTS OF COMBINED CIRCULAR AND TRANSITION CURVE

- IP = HORIZONTAL INTERSECTION POINT
- TP,PT = TANGENT POINT
- R = RADIUS OF CIRCULAR CURVE
- S = SHIFT
- LS = LENGTH OF TRANSITION
- LC = LENGTH OF CIRCULAR CURVE
- Δ = DEFLECTION ANGLE
- L = LENGTH OF CURVE

NOTE:
Widening to be attained over the Length of superelevation run - off.

Government of Nepal Ministry of Physical Infrastructure & Transport Department of Roads			
STANDARD DRAWINGS FOR ROAD ELEMENTS			
MISCELLANEOUS GEOMETRIC DETAILS			
TYPICAL DRAWINGS: CURVE			
Signature	Recommended by	Approved by	SHEET. NO. 03
	Arjun Jung Thapa	Devendra Karki	
Designation	Deputy Director General	Director General	

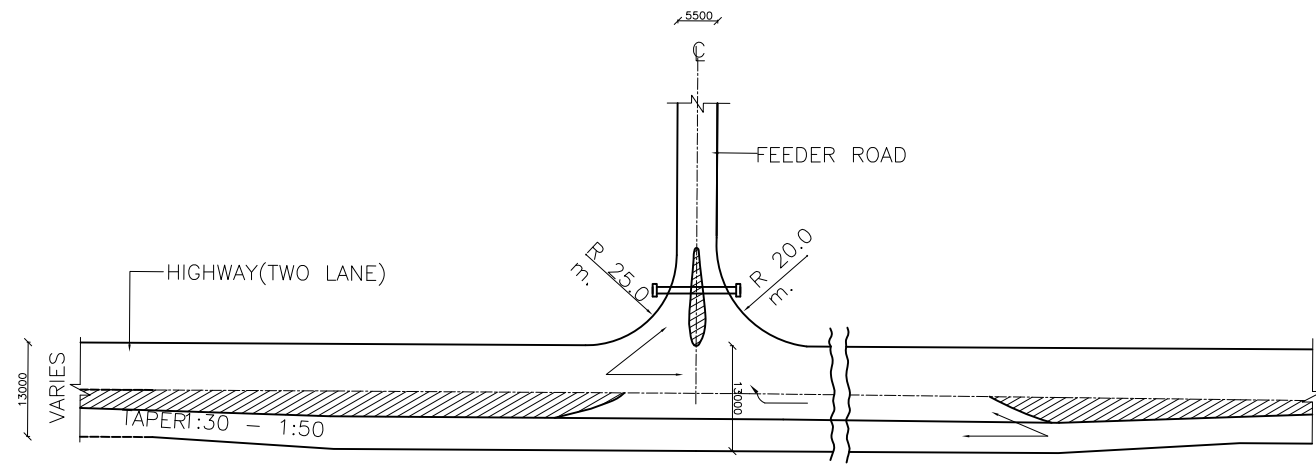

WIDENING TWO LANE CARRIAGEWAY FOR RIGHT TURNING TRAFFIC
TYPE A

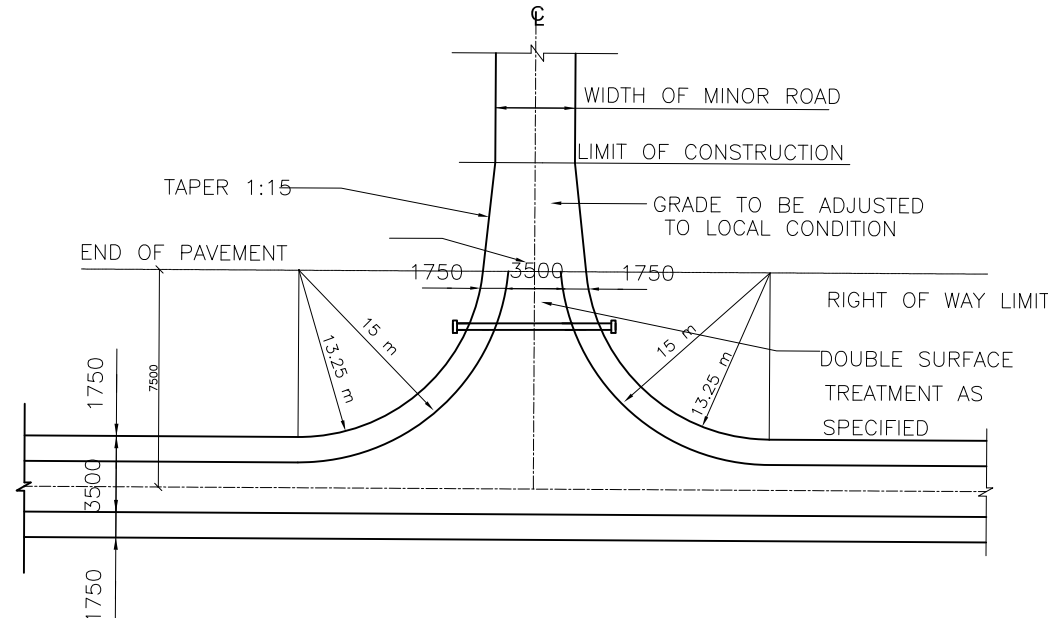

MINOR FEEDER ROAD INTERSECTION (DIRT ROAD)
TYPE B

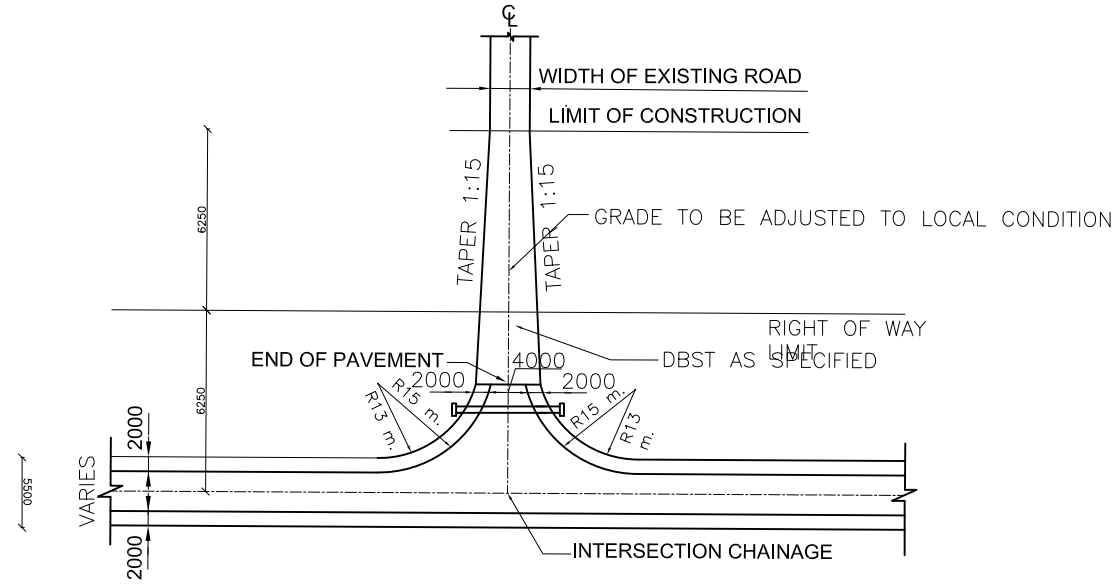

MINOR FEEDER ROAD INTERSECTION PLAN (GRAVEL ROAD)
TYPE C

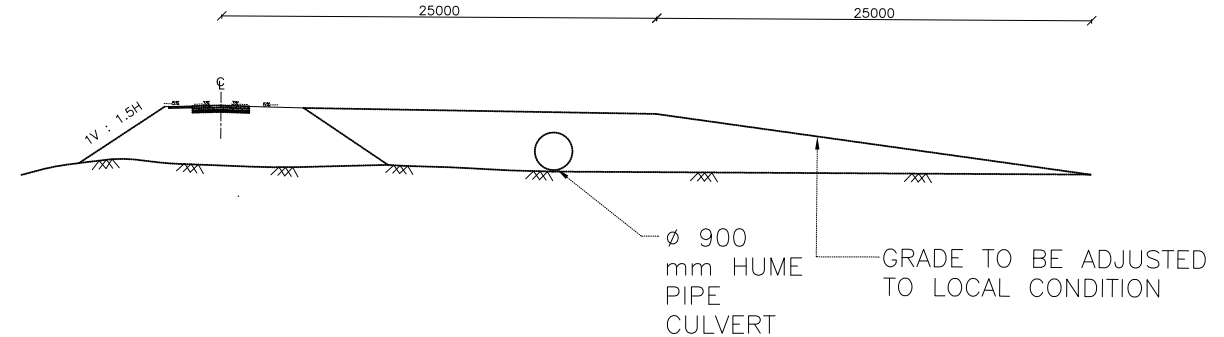

TYPICAL MINOR ROAD INTERSECTION

TURNING SPEED Km / hr	R min (m)
25	15
30	27
40	45
50	70
60	95

- NOTE:
1. Type A intersection is recommended if there is heavy right turning movement.
 2. Type B and type C intersections are preferable if meeting road is local minor road.
 3. Where land is available bigger radius of turning is recommended.
 4. Limit of construction length along the access road will be minimum 1500 mm.
 5. Install RCC slab and necessary foundation work across intersection where required.
 6. All dimensions are in mm unless otherwise stated.
 7. Turning radius should be designed as mentioned in the table.

Government of Nepal
Ministry of Physical Infrastructure & Transport
Department of Roads

STANDARD DRAWINGS FOR ROAD ELEMENTS

MISCELLANEOUS GEOMETRIC DETAILS

TYPICAL DRAWINGS: ROAD INTERSECTIONS

Recommended by	Approved by	SHEET. NO. 04
Signature	Signature	
Designation	Designation	

Arjun Jung Thapa
Deputy Director General

Devendra Karki
Director General

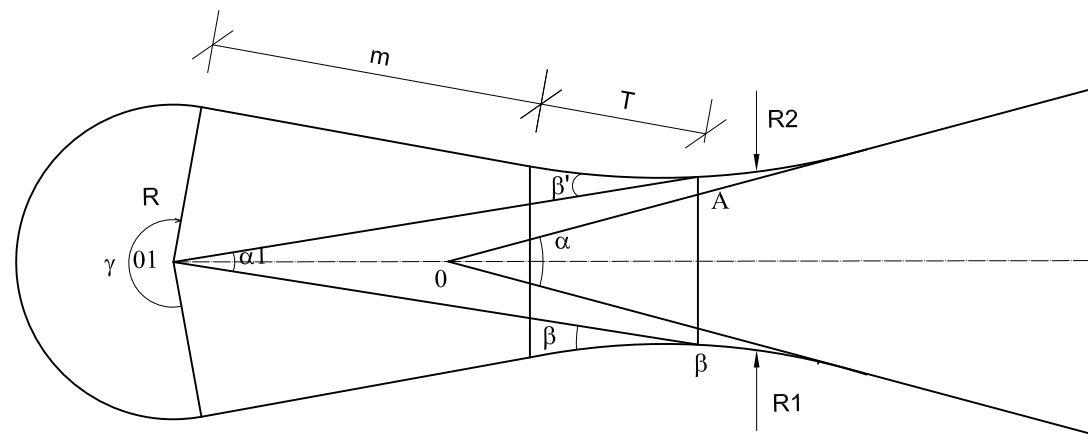

EXTENDED

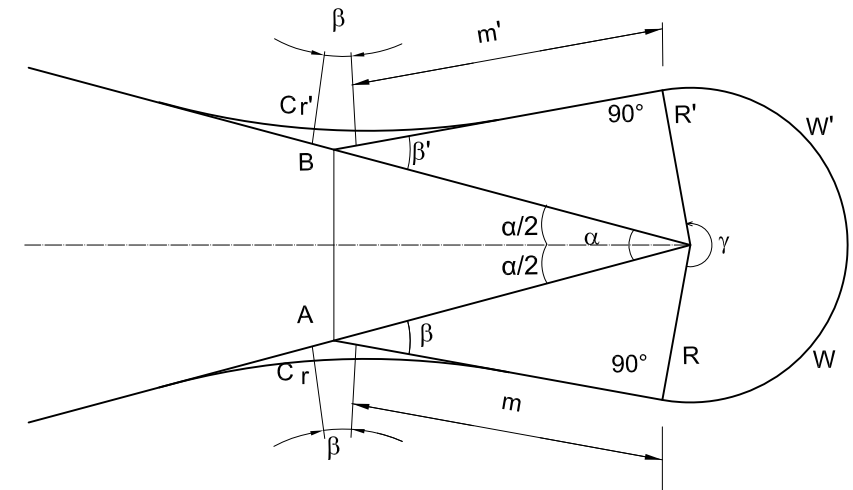

$$\gamma = 360^\circ - 2(90^\circ - \beta) - \alpha = 180^\circ + 2\beta - \alpha$$

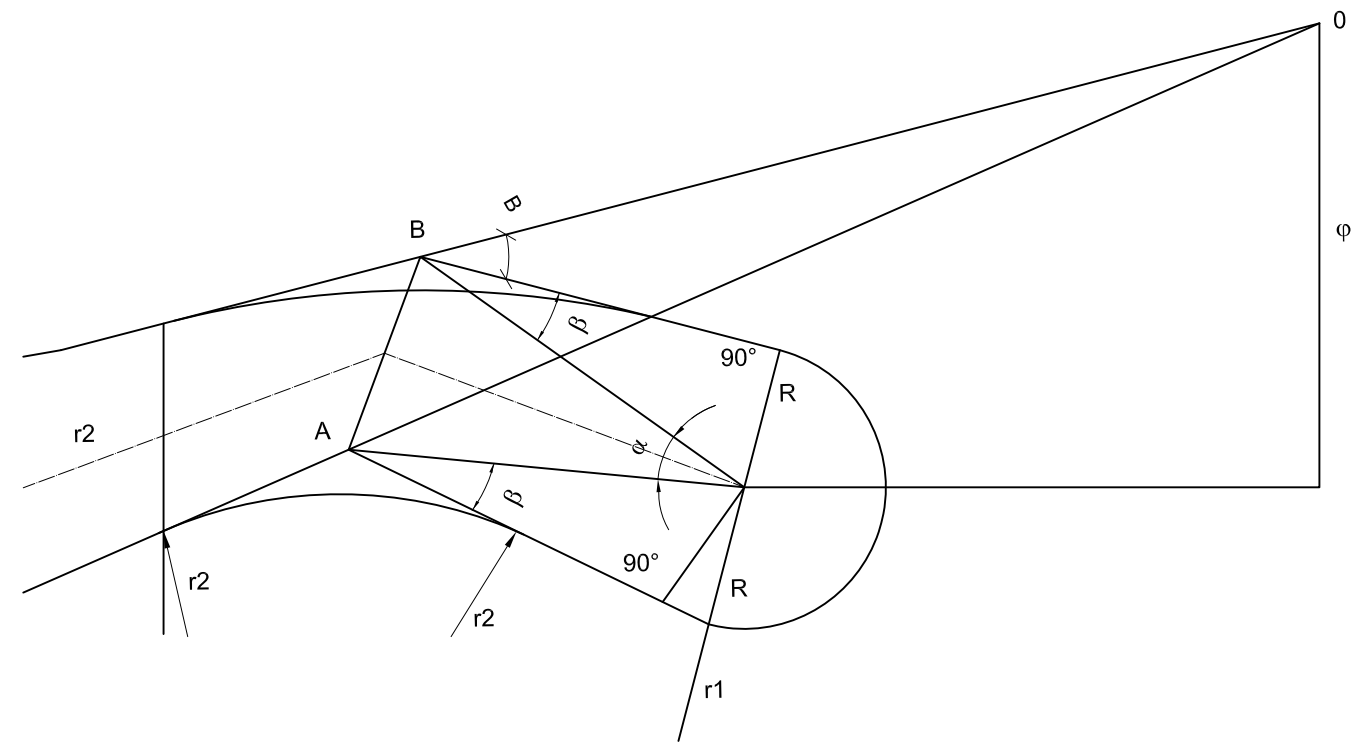
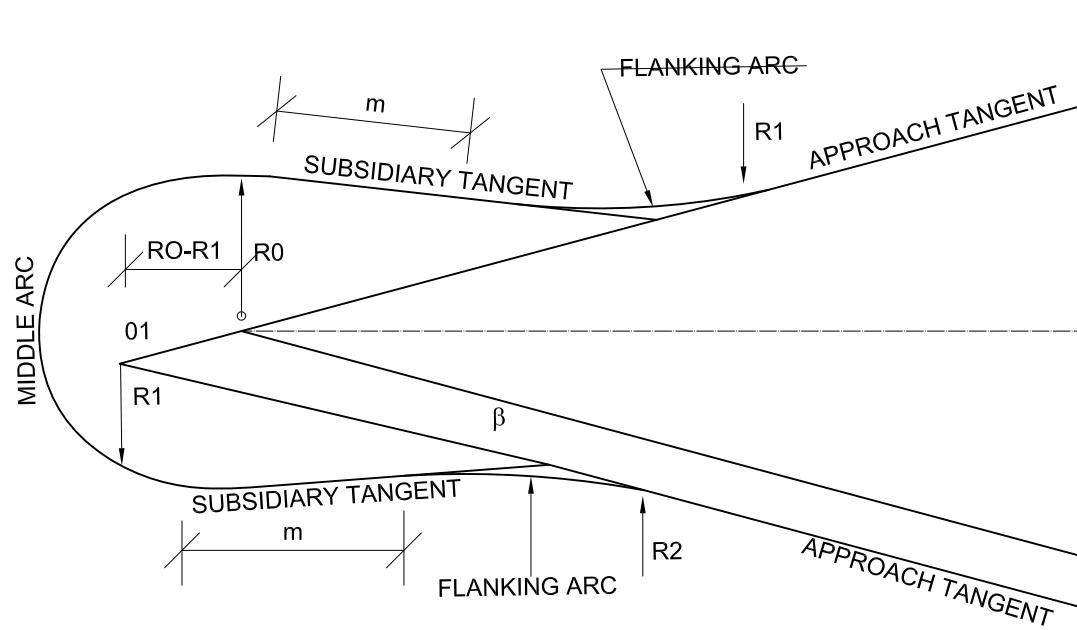

HAIR PIN DETAILS

SUBSIDIARY TANGENT, $K=m+r \tan \text{Abs}(B/2)$
 SUBSIDIARY TANGENT, $K'=m'+r' \tan \text{Abs}(B'/2)$

Government of Nepal Ministry of Physical Infrastructure & Transport Department of Roads			
STANDARD DRAWINGS FOR ROAD ELEMENTS			
GEOMETRIC DETAILS: Hairpin Bends			
TYPICAL DRAWING			
Signature	Recommended by	Approved by	SHEET. NO. 05
	Arjun Jung Thapa	Devendra Karki	
Designation	Deputy Director General	Director General	

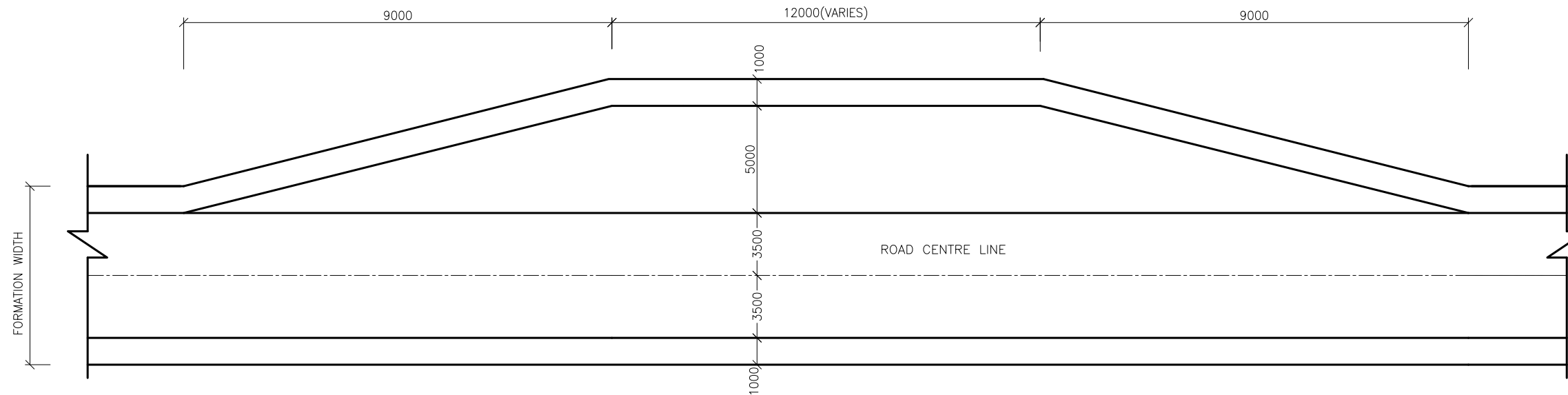

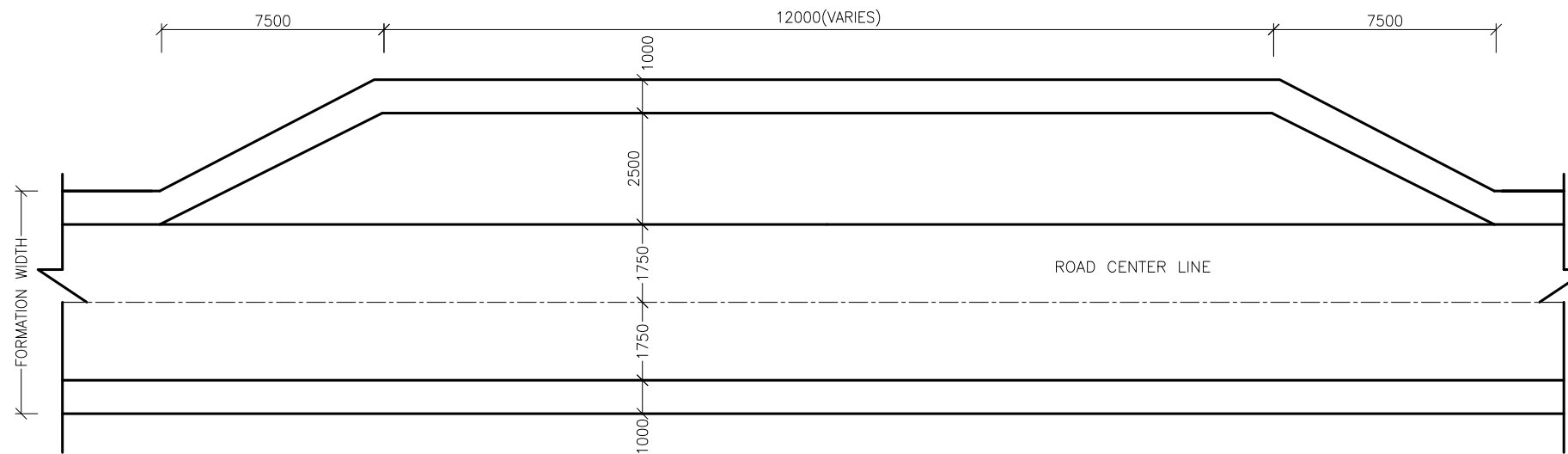

TYPICAL BUSBAY
(SCALE 1:100)



TYPICAL PASSING ZONE
(SCALE 1:100)

NOTE:

1. All dimension are in mm unless stated otherwise.
2. Length of the busbay and passing zone may vary to suit site condition and terrain.
3. Length of the busbay depends upon number of buses they may have to accommodate.
4. The exact location of passing zone should be judiciously determined taking into consideration the available extra width and visibility.

 Government of Nepal Ministry of Physical Infrastructure & Transport Department of Roads			
STANDARD DRAWINGS FOR ROAD ELEMENTS			
BUSBAY AND PASSING ZONE			
TYPICAL DRAWING			
	Recommended by	Approved by	
Signature			SHEET. NO. 06
	Arjun Jung Thapa	Devendra Karki	
Designation	Deputy Director General	Director General	

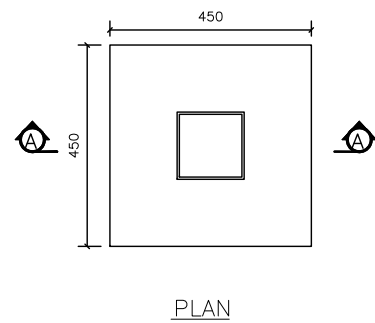

PLAN

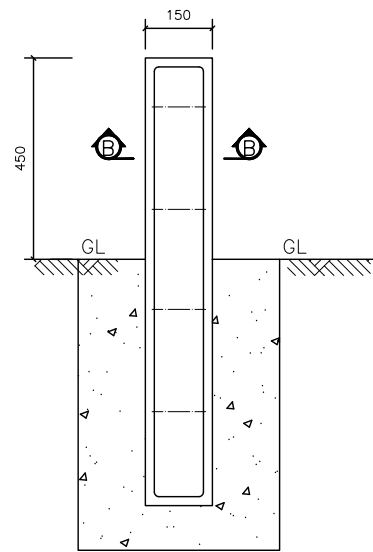

SECTION A-A

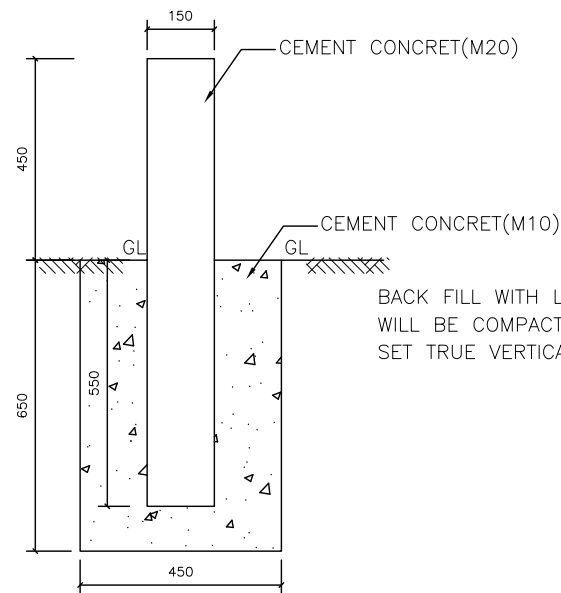

ELEVATION

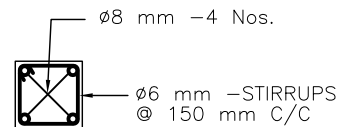

SECTION AT B-B

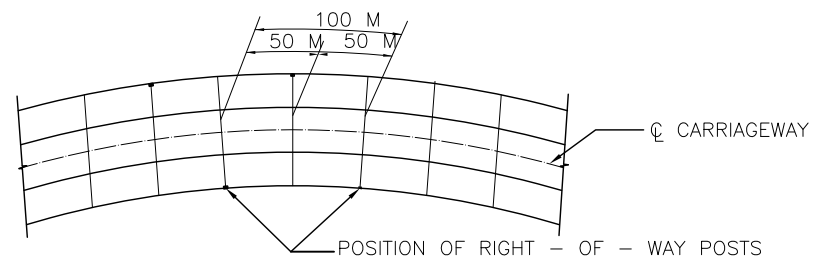

RIGHT OF WAY MONUMENTS

BENCH MARKS

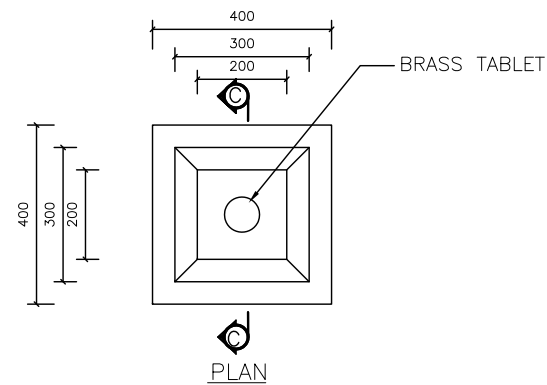

PLAN

BRASS TABLET

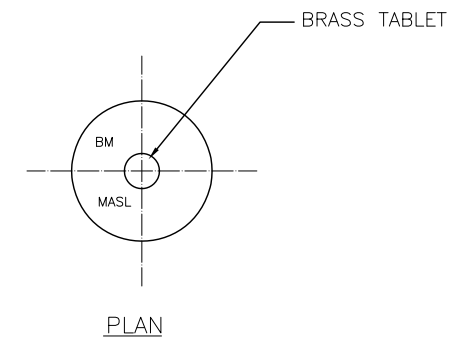

PLAN

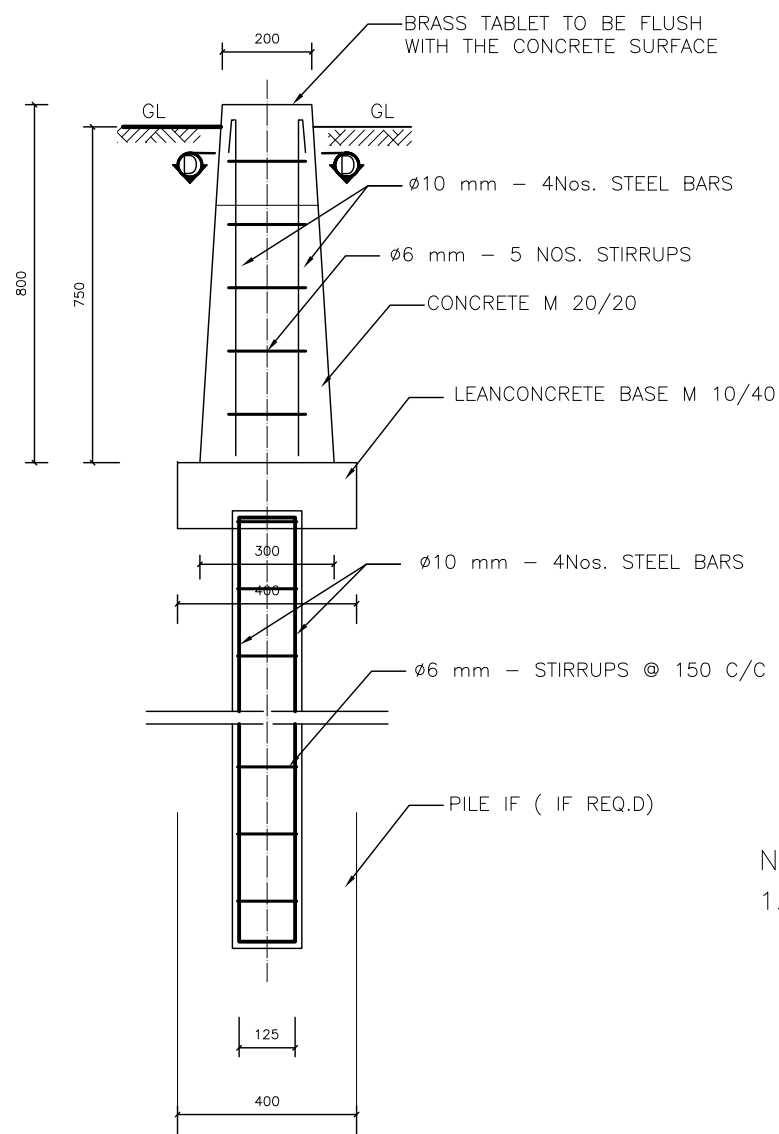

SECTION C-C

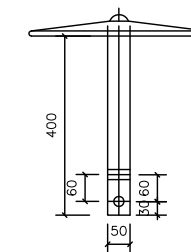

ELEVATION

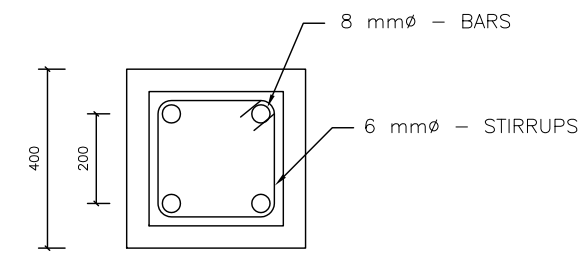

SECTION AT D-D

NOTE:

1. All dimension are in mm unless otherwise stated

Government of Nepal Ministry of Physical Infrastructure & Transport Department of Roads			
STANDARD DRAWINGS FOR ROAD ELEMENTS			
BENCHMARK & ROW MONUMENT			
TYPICAL DRAWING			
Signature	Recommended by	Approved by	SHEET. NO. 07
	Arjun Jung Thapa	Devendra Karki	
Designation	Deputy Director General	Director General	

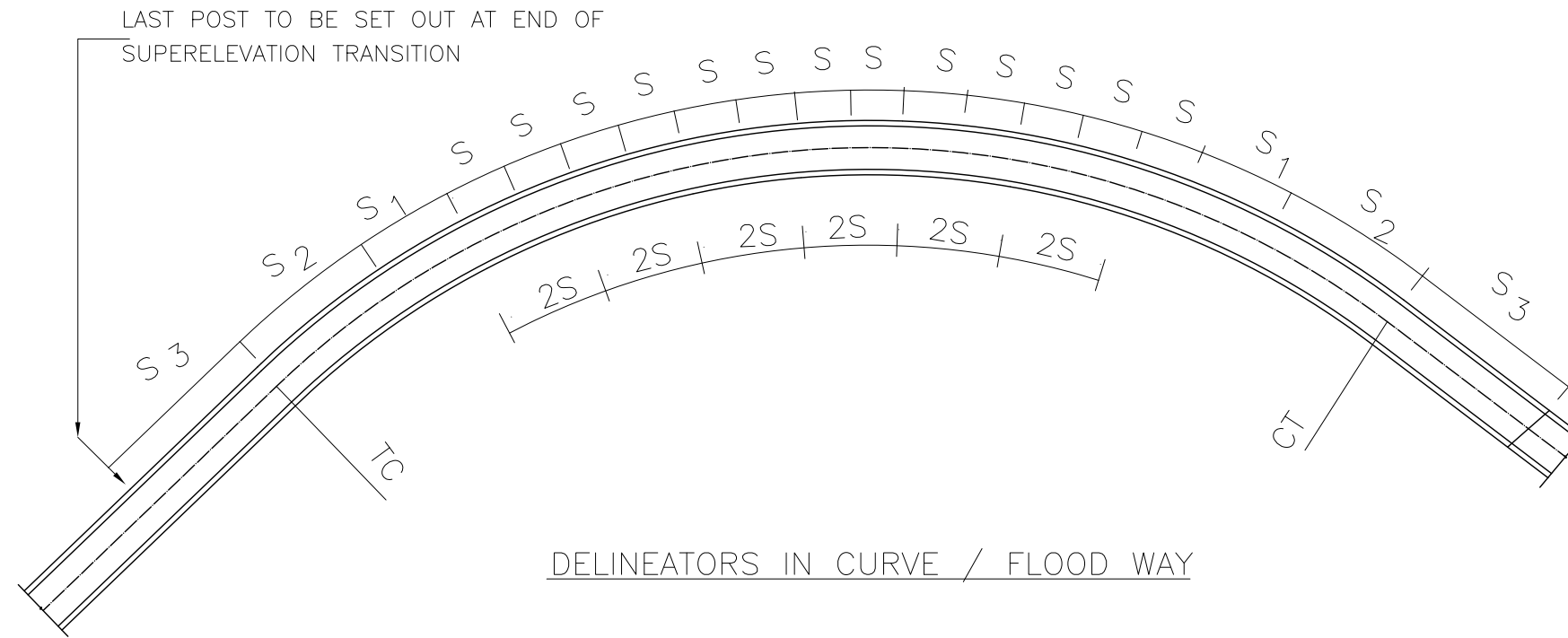



Recommended Spacing for Delineator Posts

Radius of curve, m	Spacing on curve, m			
	S	S1	S2	S3
Up to 20	3	5	7	12
40	5	7	10	20
60	7	10	15	28
80	9	13	22	35
100	10	15	25	40
120	11	17	28	44
140	12	19	31	48
160	13	21	34	50
180	14	23	37	50
200	15	25	40	50
300	20	30	45	50
400	30	45	50	50
500	No Delineators Installed			

SOURCE IRC79-1980(2004)

NOTE:

Half of the delinator post shall be embedded to the ground.

 Government of Nepal Ministry of Physical Infrastructure & Transport Department of Roads			
STANDARD DRAWINGS FOR ROAD ELEMENTS			
DELINEATORS SPACING			
TYPICAL DRAWING			
	Recommended by	Approved by	
Signature			SHEET. NO. 08
	Arjun Jung Thapa	Devendra Karki	
Designation	Deputy Director General	Director General	

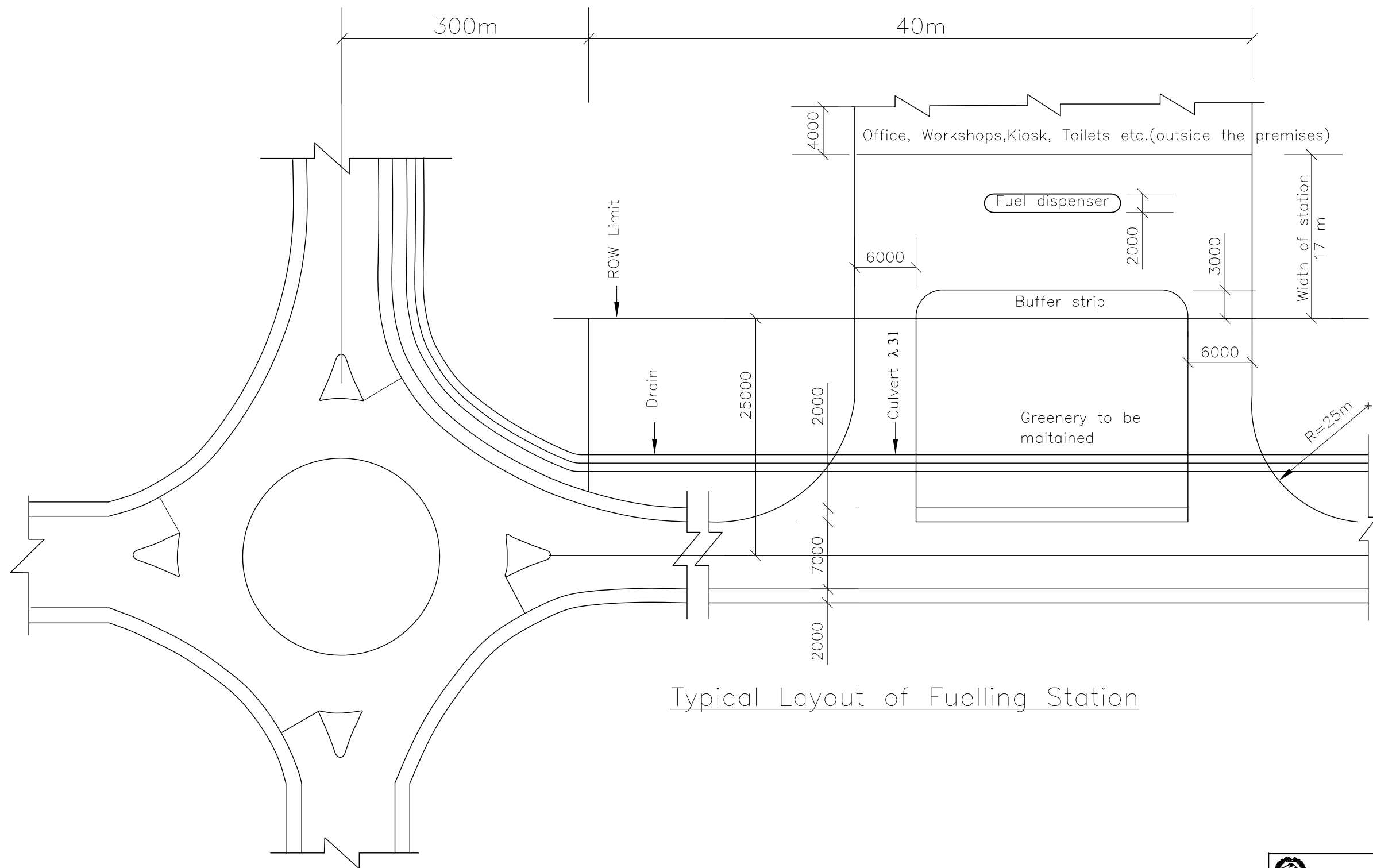

Typical Layout of Fuelling Station

Note:
1. All dimensions are in mm unless otherwise stated.

Government of Nepal Ministry of Physical Infrastructure & Transport Department of Roads			
STANDARD DRAWINGS FOR ROAD ELEMENTS			
PETROL PUMP STATION FOR PLAINS			
TYPICAL DRAWING			
	Recommended by	Approved by	SHEET. NO. 09
Signature	<i>[Signature]</i>	<i>[Signature]</i>	
	Arjun Jung Thapa	Devendra Karki	
Designation	Deputy Director General	Director General	

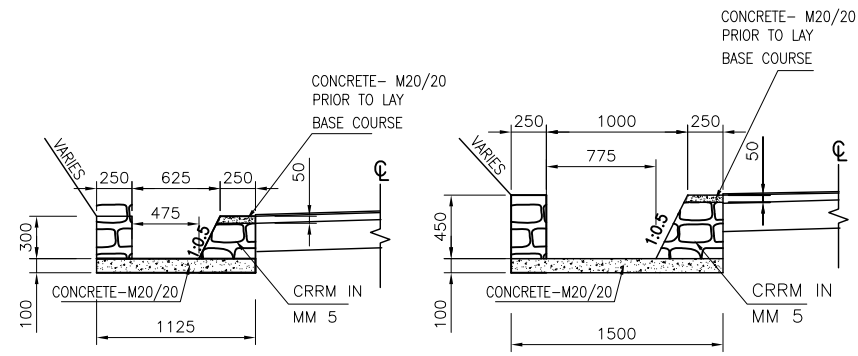

SIDE DRAIN - D1

SIDE DRAIN - D2

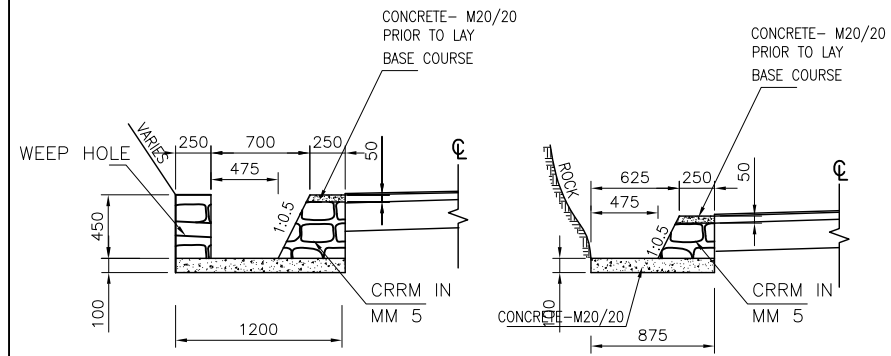

SIDE DRAIN - D3

SIDE DRAIN - D4

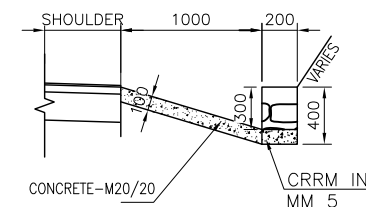

SIDE DRAIN - D5A

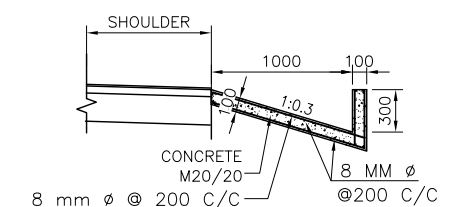

SIDE DRAIN - D5B

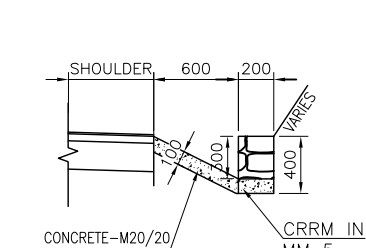

SIDE DRAIN - D5C

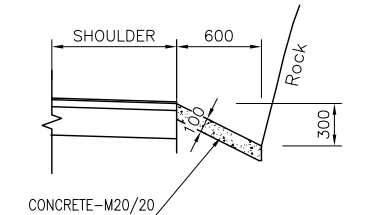

SIDE DRAIN - D5D

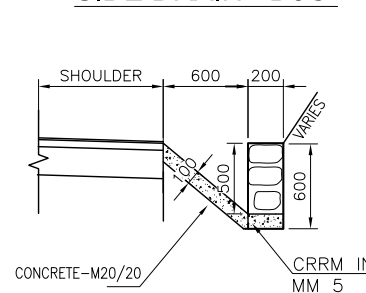

SIDE DRAIN - D5E

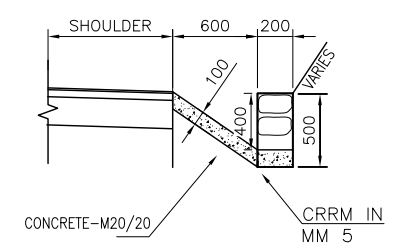

SIDE DRAIN - D5F

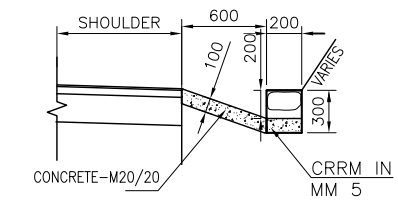

SIDE DRAIN - D5G

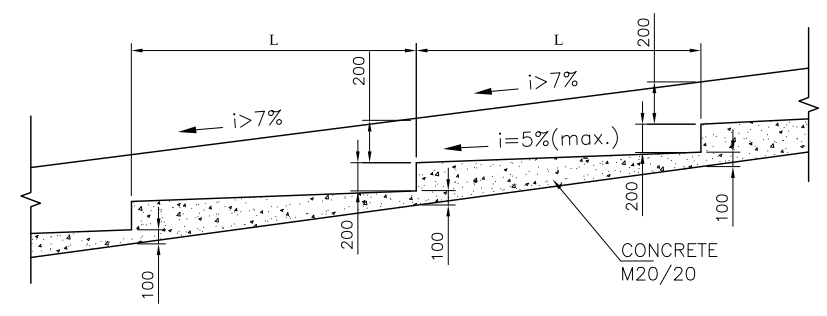

DRAIN PROFILE

Notes:

1. M20/20-Concrete will be placed to maintain flow depth of MIN 300mm.
2. Gradient is greater than 7% drop will be provided or as directed.
3. Min. 5% slope be provided for the drain with drops.

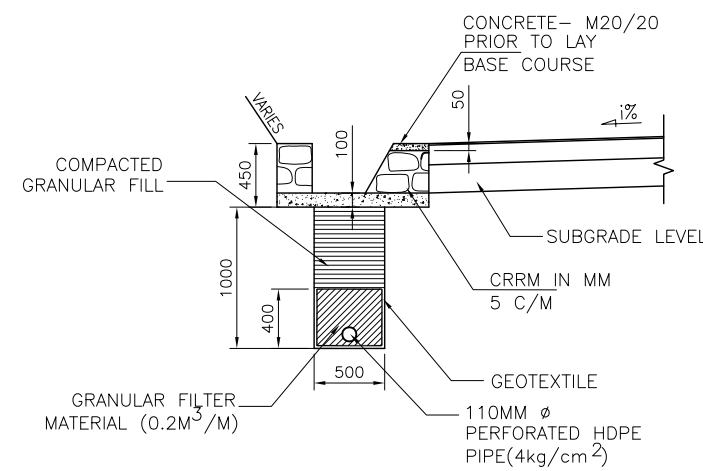

TYPICAL SUB-SURFACE DRAIN
(LOCATION AS DIRECTED)

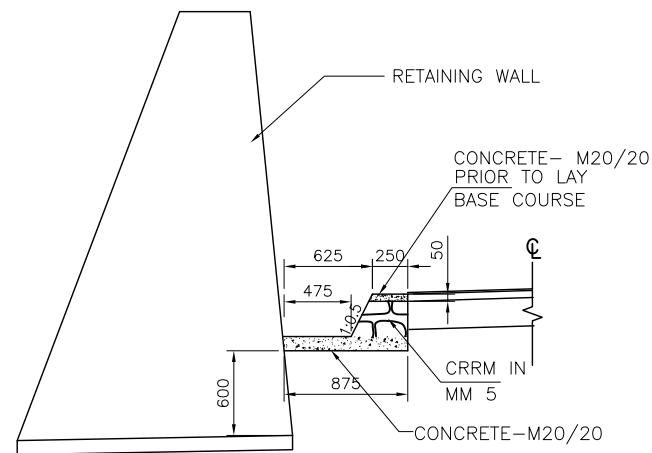

SIDE DRAIN - D6 [WITH RETAINING WALL]

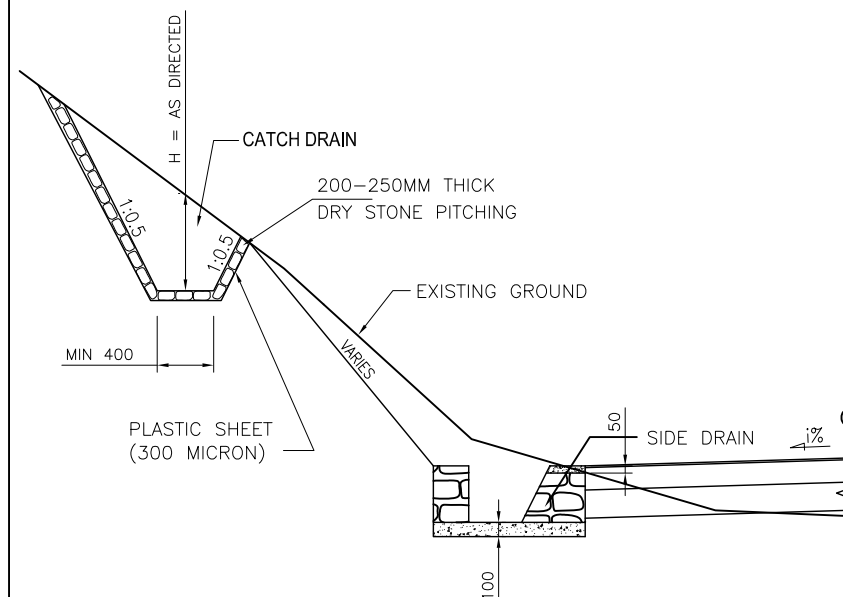

CATCH WATER DRAIN - D7

Notes:

1. Side Drain- D5C, D5D & D5E is to be used in narrow road in general.
2. Side Drain-D5B is to be used in narrow road in settlement area.

Government of Nepal Ministry of Physical Infrastructure & Transport Department of Roads			
STANDARD DRAWINGS FOR ROAD ELEMENTS			
SIDE DRAINS			
TYPICAL DRAWING			
Recommended by	Approved by		SHEET. NO. 10
Signature	Signature		
Designation	Designation		
Deputy Director General	Director General		

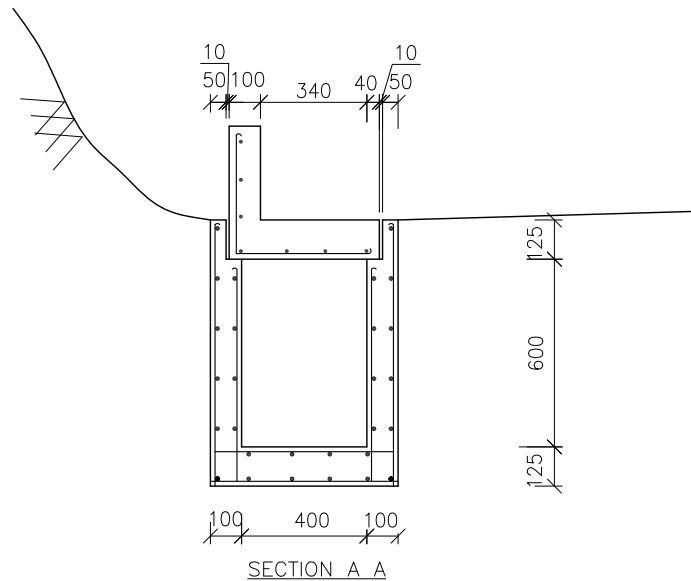

SECTION A A

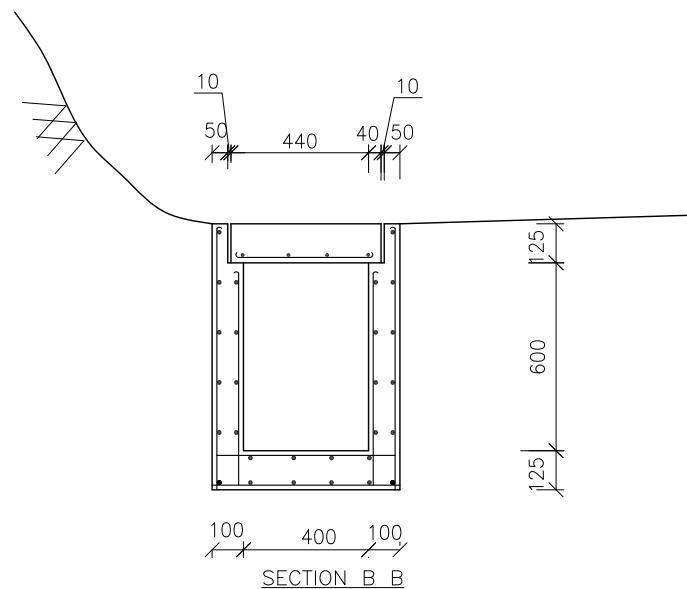

SECTION B B

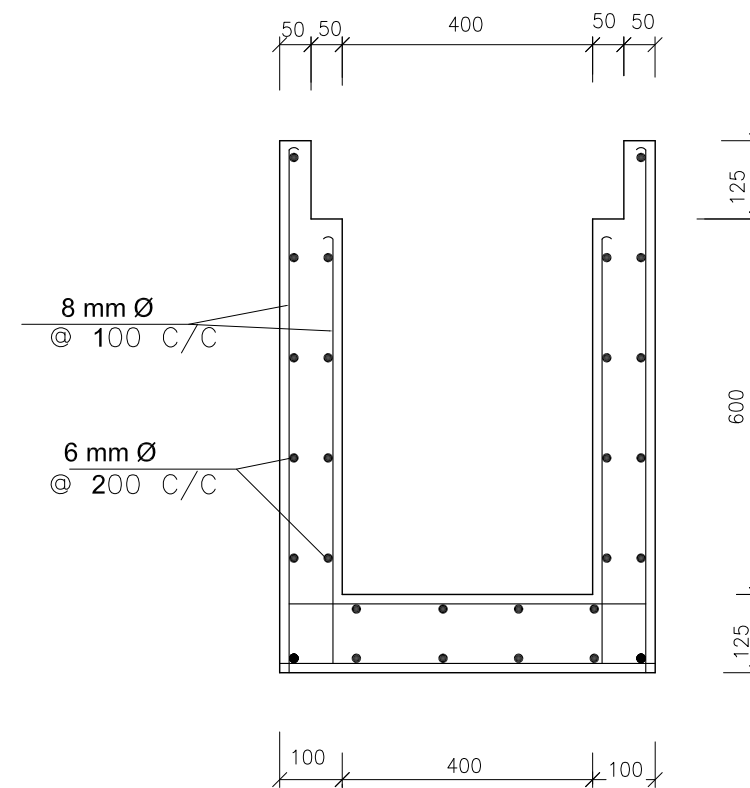

RCC PRE-CAST DRAIN

SLOT IN COVER TO BE CENTRALLY LOCATED

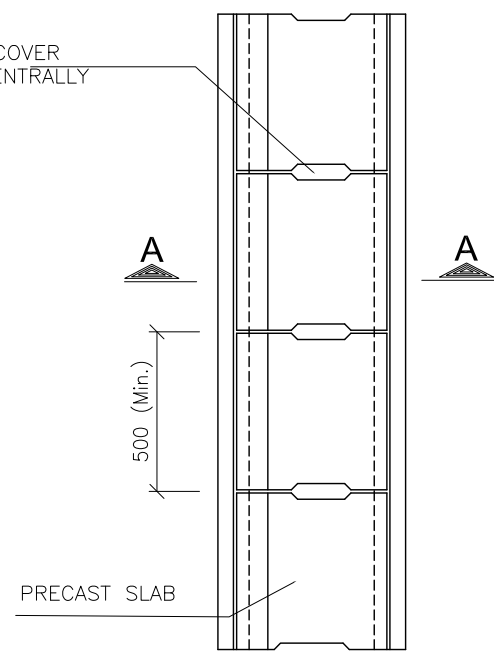

PLAN OF PRECAST DRAIN WITH L TYPE COVER

SLOT IN COVER TO BE CENTRALLY LOCATED

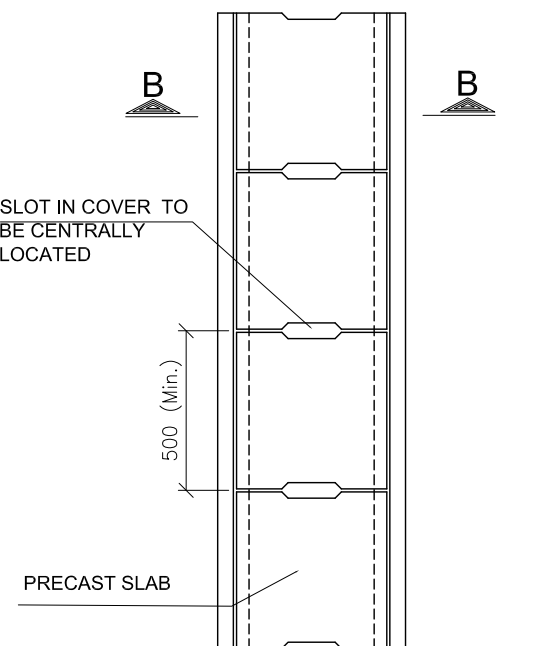

PLAN OF RCC PRECAST DRAIN WITH PLAIN COVER

NOTE:

1. All dimensions are in mm unless stated otherwise.
2. The side drains are provided with minimum gradient of 3%.
3. The dimensions of the side drain could be varied according to design discharge.
4. Concrete M 25

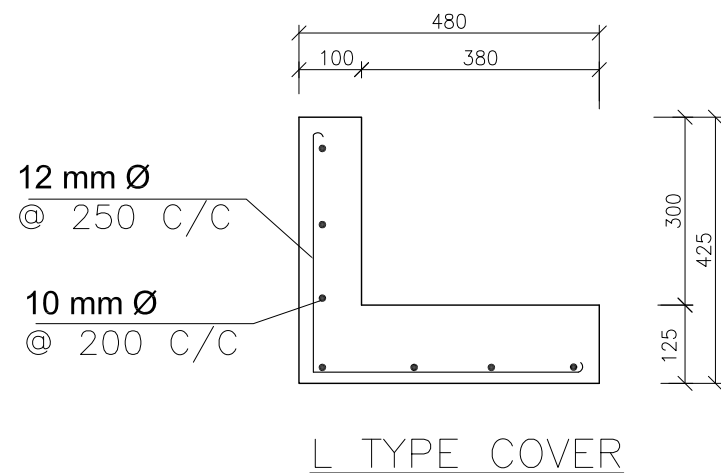

L TYPE COVER

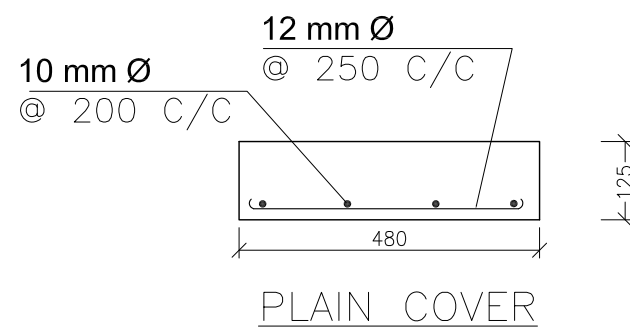

PLAIN COVER

Government of Nepal Ministry of Physical Infrastructure & Transport Department of Roads			
STANDARD DRAWINGS FOR ROAD ELEMENTS			
PRE-CAST RCC SIDE DRAIN			
TYPICAL DRAWING			
Signature	Recommended by	Approved by	SHEET. NO. 11
	Arjun Jung Thapa	Devendra Karki	
Designation	Deputy Director General	Director General	

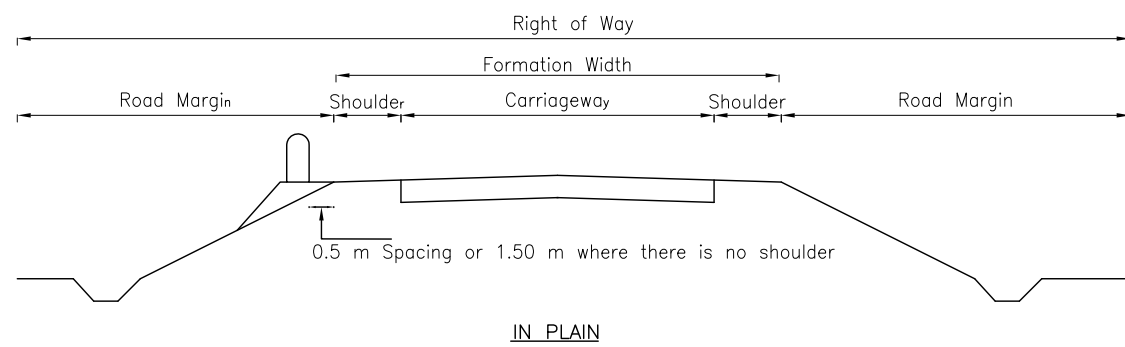
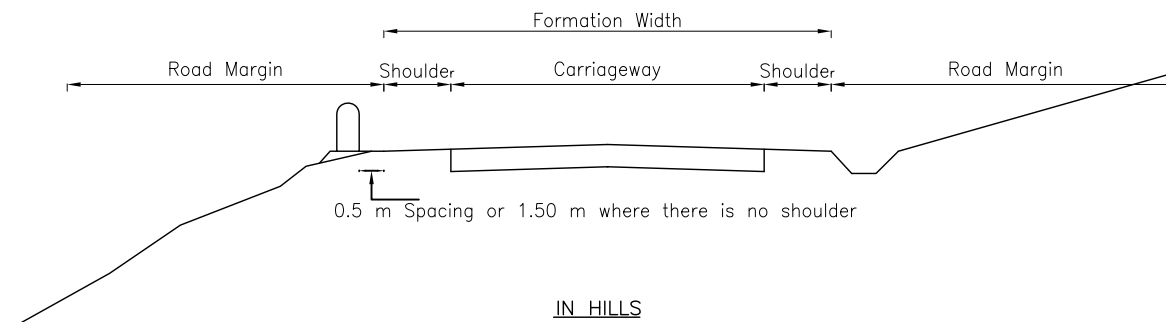
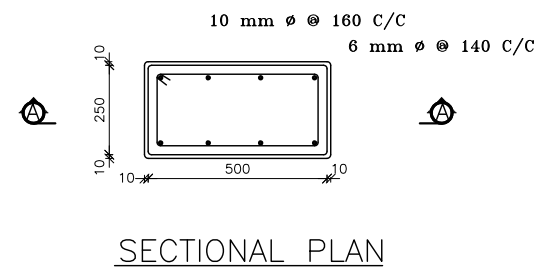
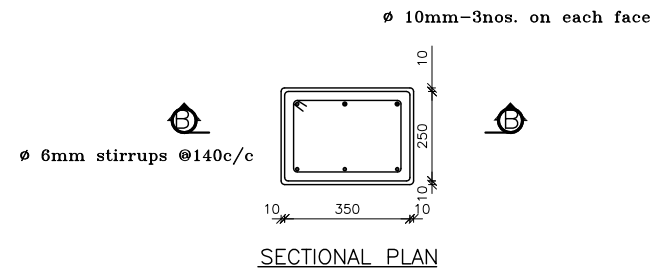
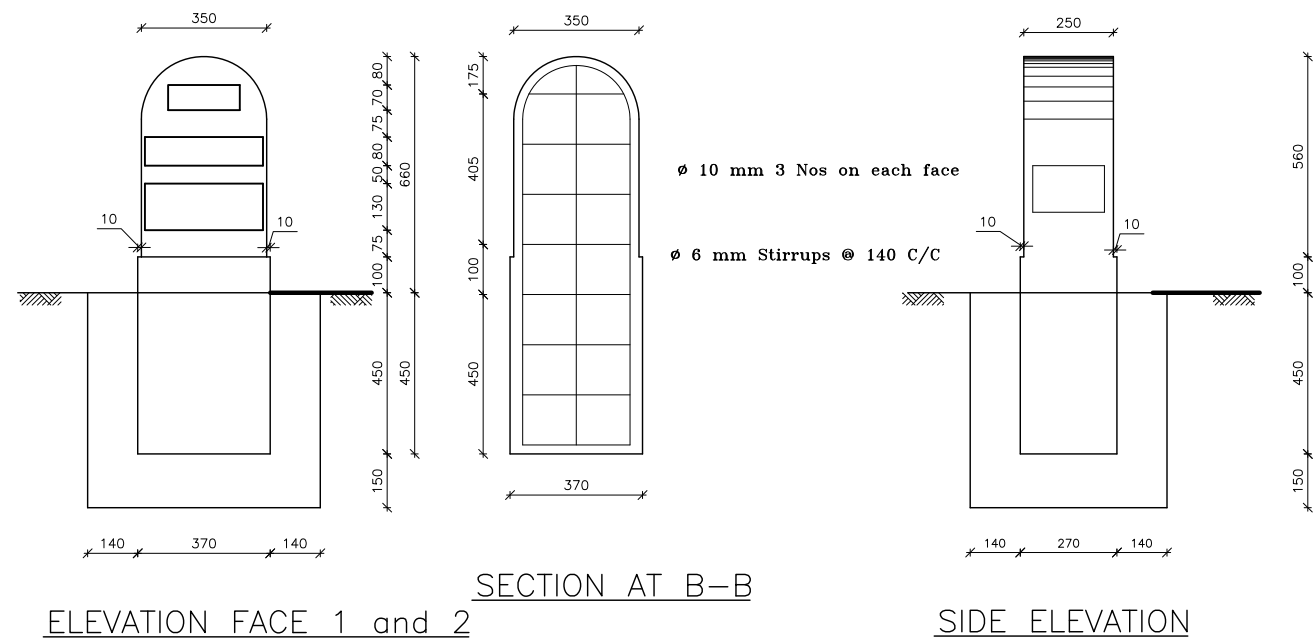
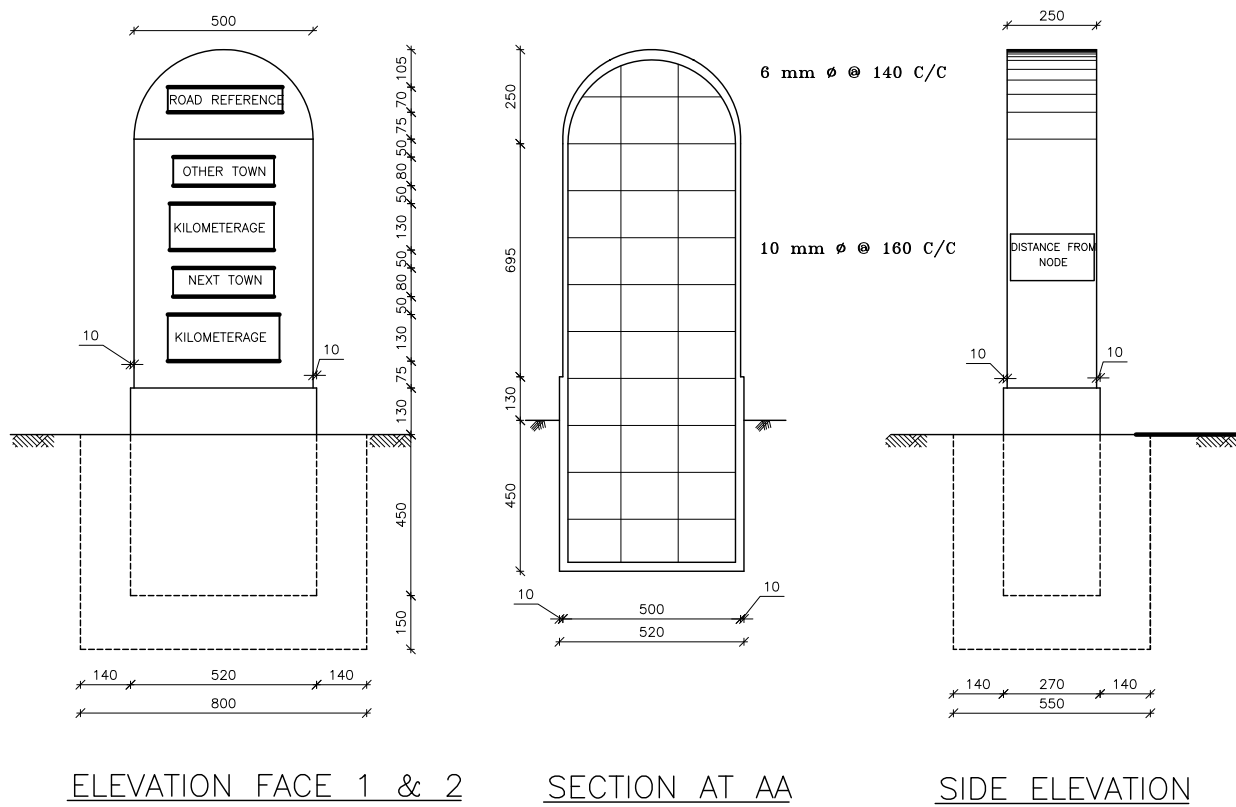

NOTE:

1. All dimensions are in mm unless otherwise stated.
2. Alternate km and 5km post will be in Nepali and English language.
3. Lettering size will be as given in the box.
4. The back ground of the post will be painted in white and deep black paints will be used for letters & numerals.
5. Top half circle shall be painted in yellow colour.
6. In hilly terrain the post will be located in the valley side of the road and in plain area will be located on the left side as one proceeds the starting station towards the terminal station.

Government of Nepal Ministry of Physical Infrastructure & Transport Department of Roads			
STANDARD DRAWINGS FOR ROAD ELEMENTS			
KILOMETER POST			
TYPICAL DRAWING			
Signature	Recommended by Arjun Jung Thapa Deputy Director General	Approved by Devendra Karki Director General	SHEET. NO. 12
Designation	Deputy Director General	Director General	

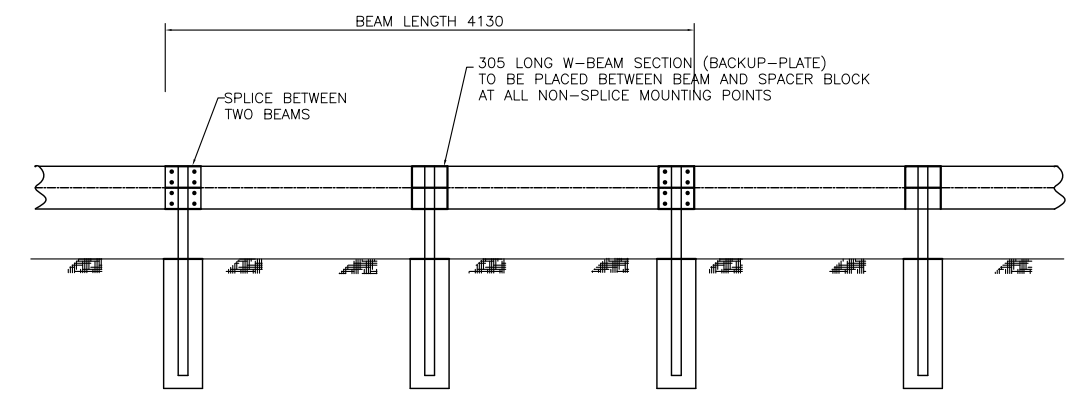
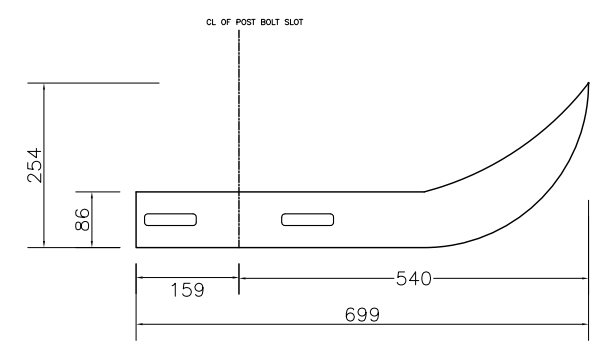
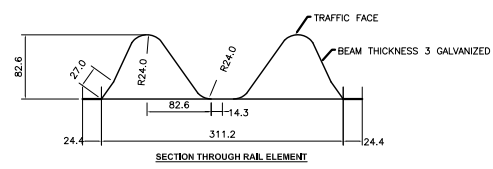

REAR ELEVATION

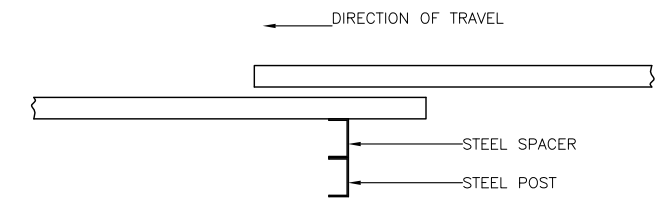

OVERLAPPING OF BEAMS AND POST POSITION TO BE AS SHOWN

BEAMS ARE OVERLAPPED AT EACH SPLICE BY 318mm AND BUTTON HEAD 16mm DIA BOLTS
 BEAMS ARE CONNECTED TO SPACER BLOCK BY ONE BUTTON HEAD 16mm DIA BOLT

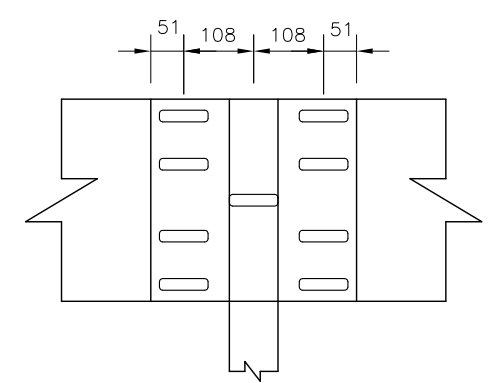

RAIL SPLICE

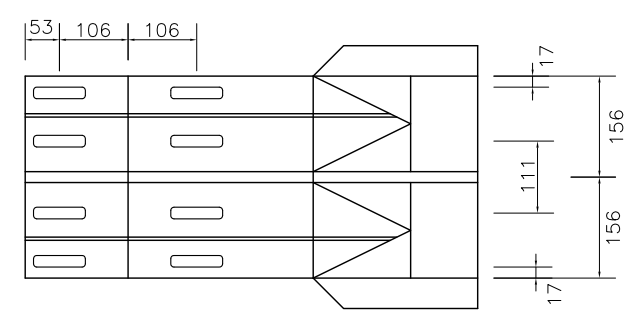

END SECTION

ONLY FOR USE AT THE DOWNSTREAM END OF THE GUARDRAIL ON ONE WAY ROADS

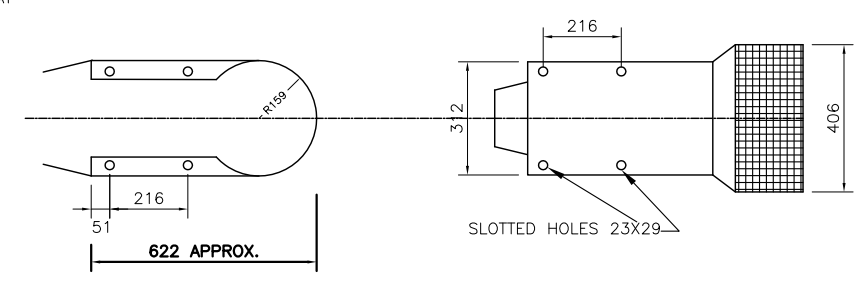

BUFFER END

NOTE :
 1. ALL DIMENSIONS ARE IN MILIMETER.
 2. ALL GUARDRAIL COMPONENTS ARE TO BE HOT DIP GALVANIZED HAVING A MASS ZINC COATING OF 550gm/m²

THERE MUST BE AT LEAST 1000 CLEARANCE BETWEEN THE BACK OF THE POST AND ANY SOLID OBJECT

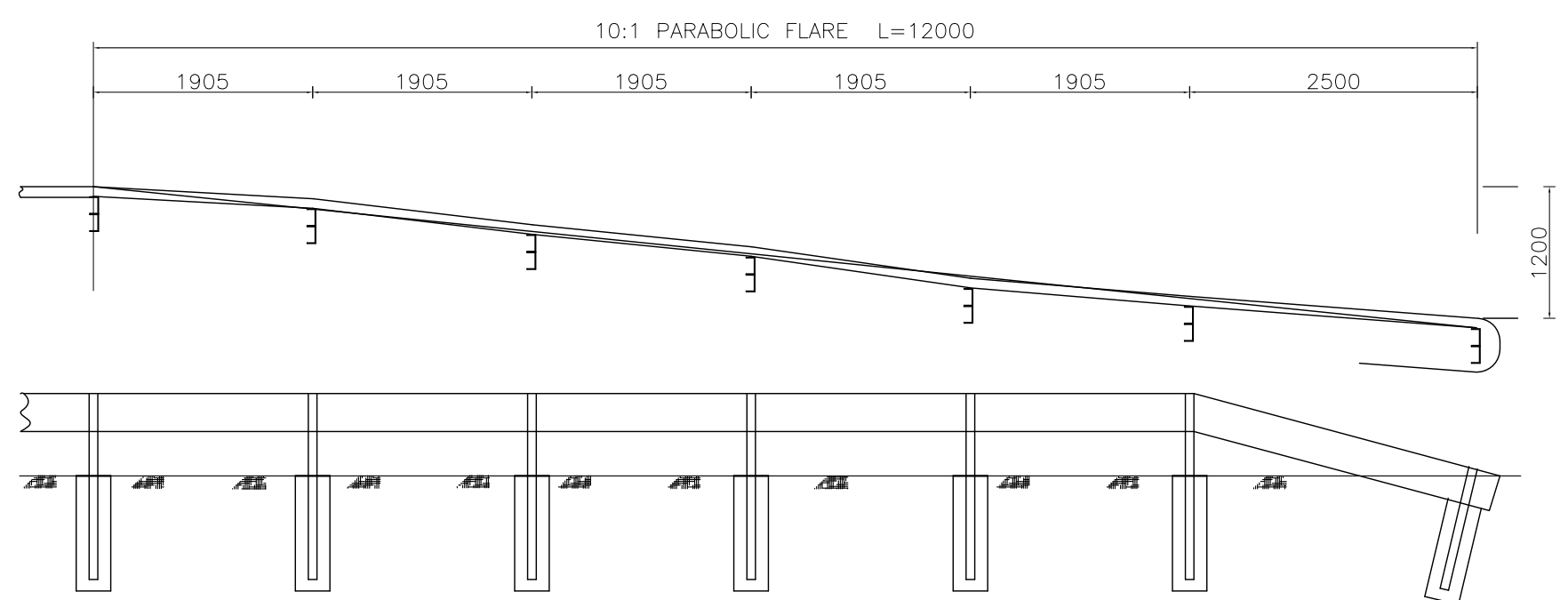
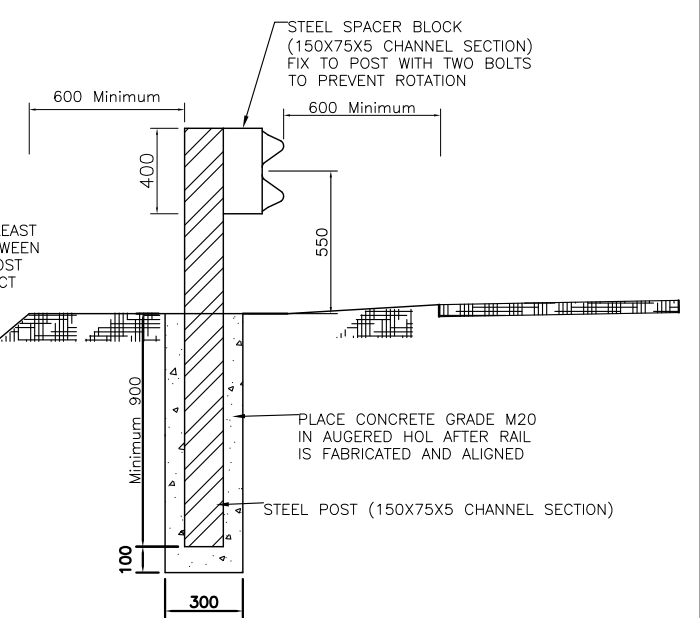

REAR ELEVATION

Government of Nepal Ministry of Physical Infrastructure & Transport Department of Roads			
STANDARD DRAWINGS FOR ROAD ELEMENTS			
ROAD SAFETY BARRIER			
TYPICAL DRAWING			
Recommended by	Approved by		SHEET. NO. 13
Signature	Signature		
Designation	Designation		
Deputy Director General	Director General		

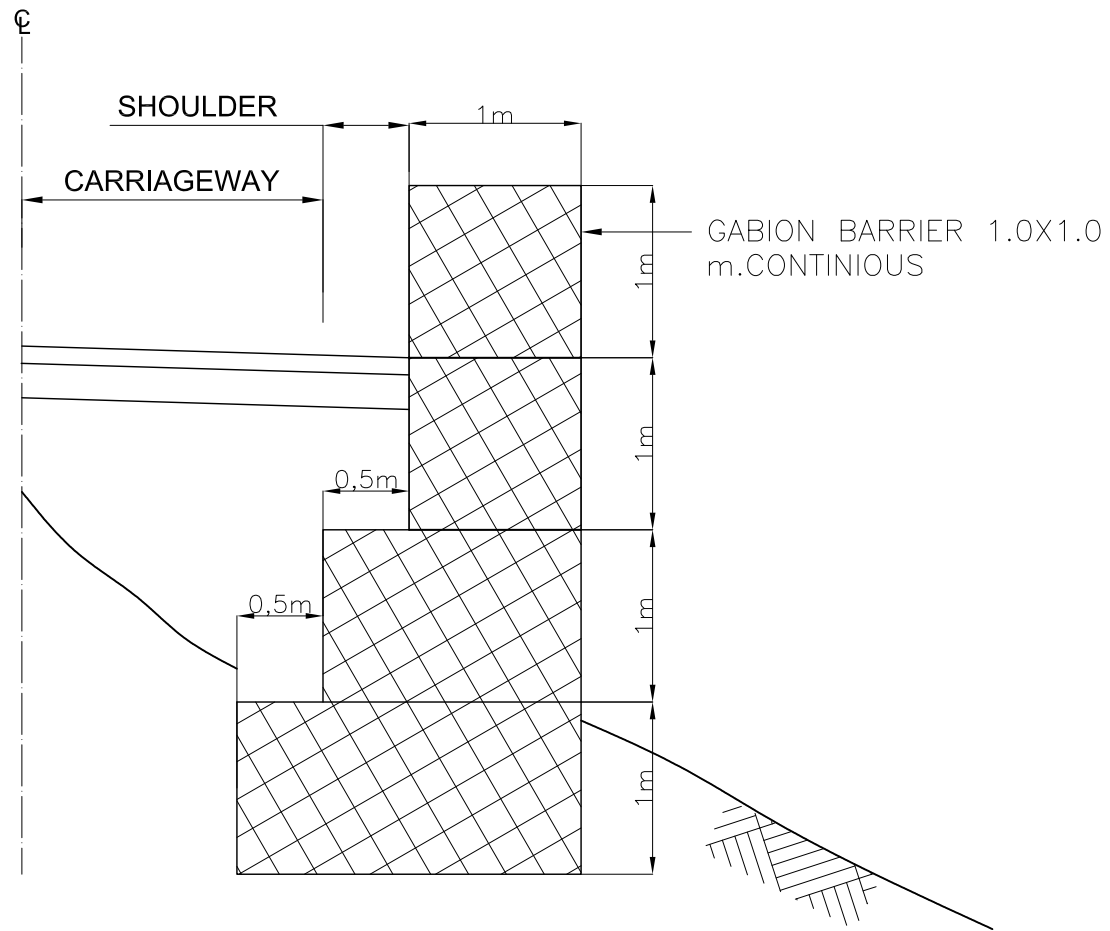

GABION BARRIER FOR GABION WALL (HEIGHT > 3.0 m)
(Scale 1:100)

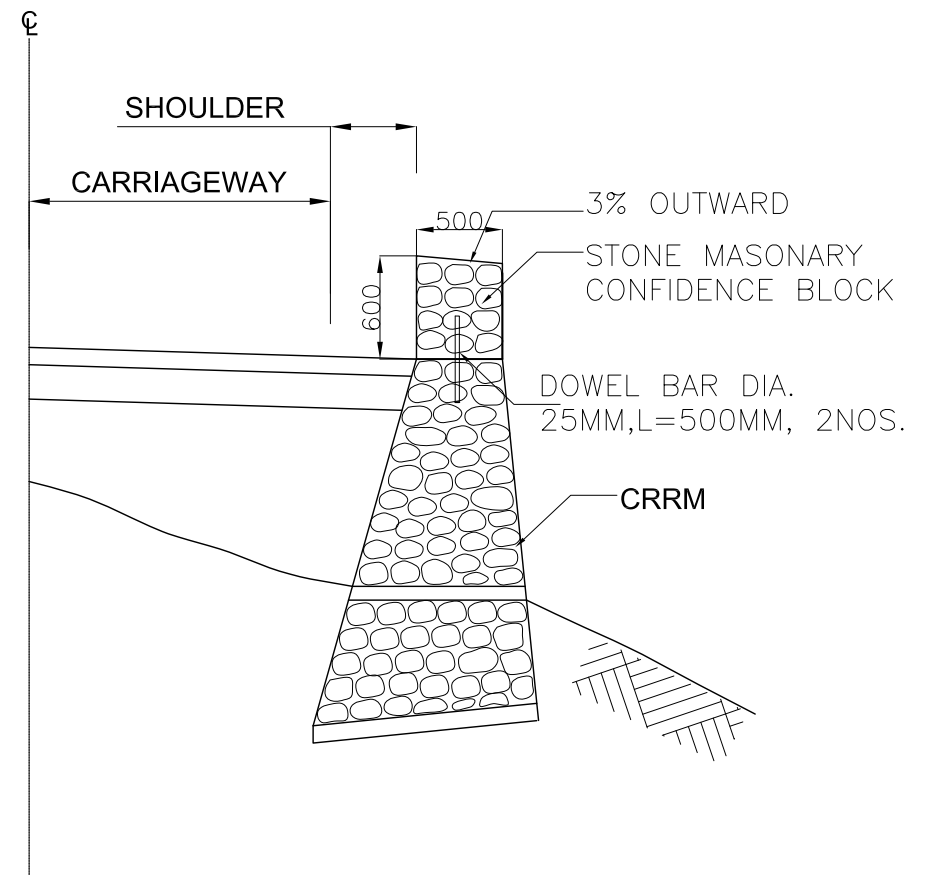

SECTIONAL VIEW OF DELINEATOR FOR CRRM WALL (HEIGHT > 3.0 m.)
(Scale 1:100)

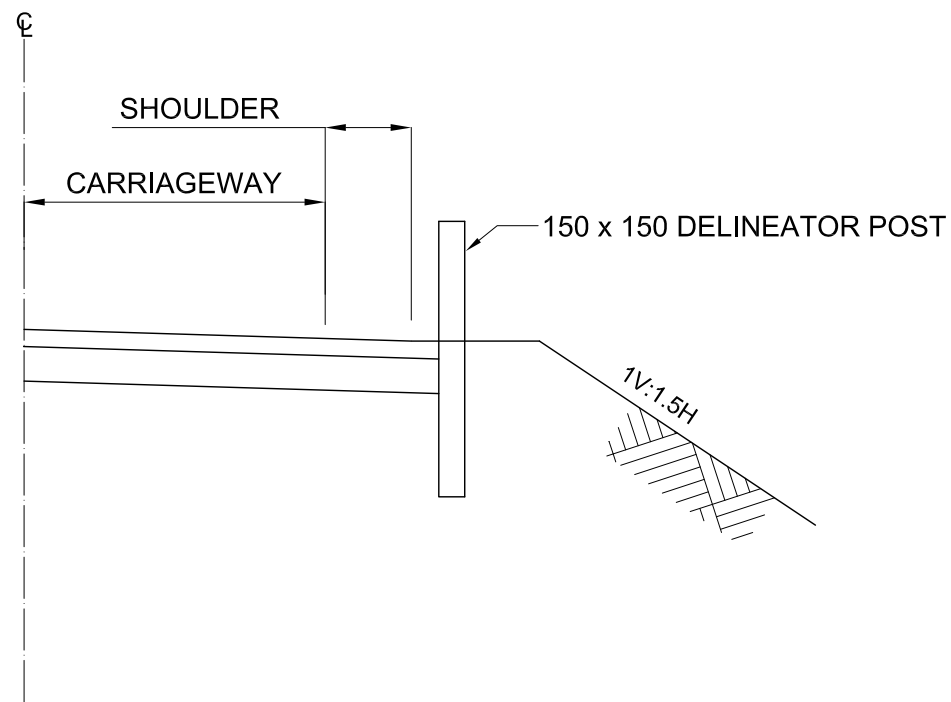

DELINEATOR FOR EMBANKMENT (HEIGHT < = 3.0 m)
(Scale 1:100)

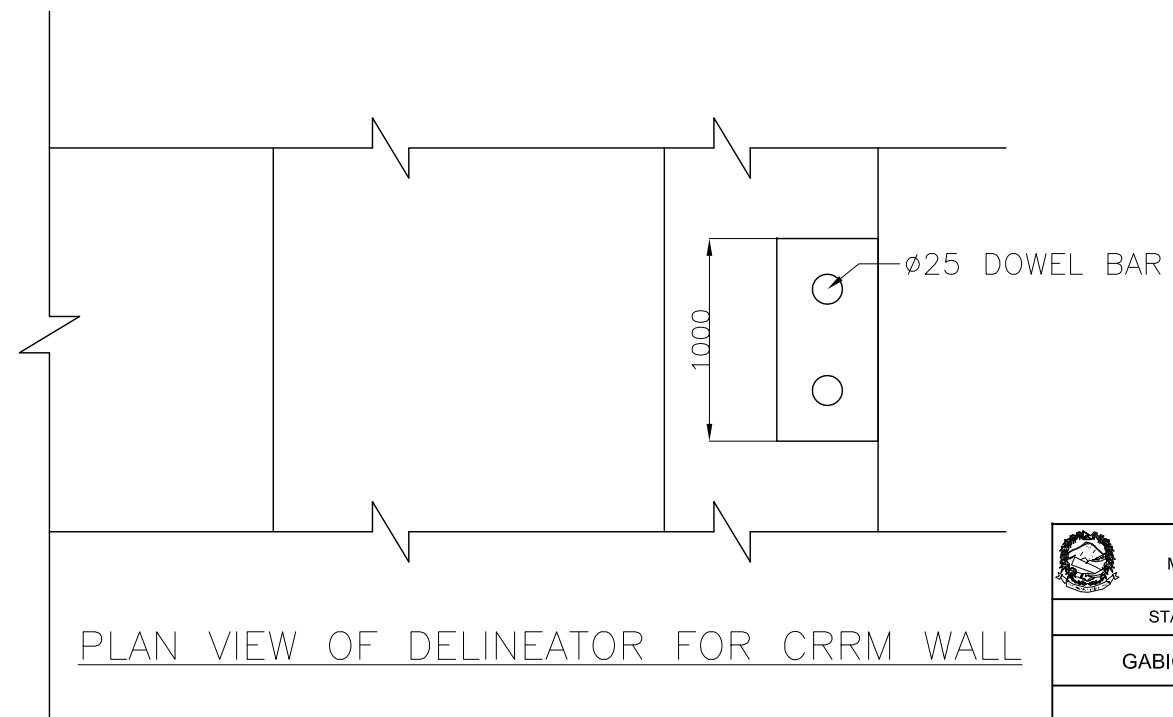

PLAN VIEW OF DELINEATOR FOR CRRM WALL

Government of Nepal Ministry of Physical Infrastructure & Transport Department of Roads			
STANDARD DRAWINGS FOR ROAD ELEMENTS			
GABION BARRIER AND DELINEATOR POST			
TYPICAL DRAWING			
Signature	Recommended by	Approved by	SHEET. NO. 14
	Arjun Jung Thapa	Devendra Karli	
Designation	Deputy Director General	Director General	

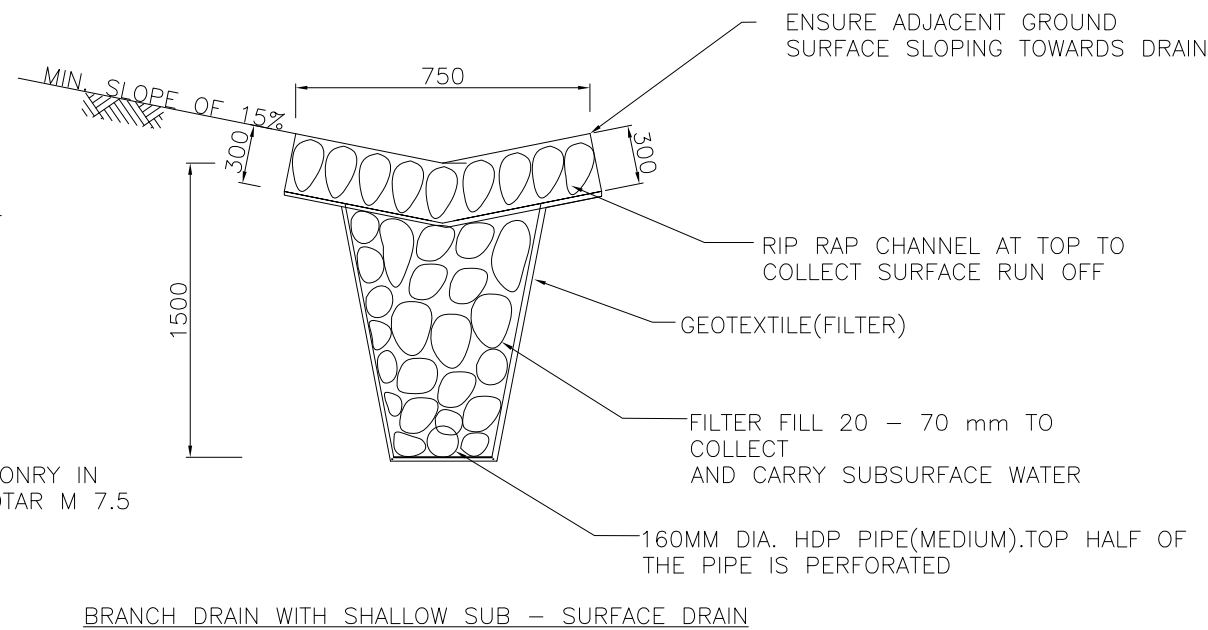
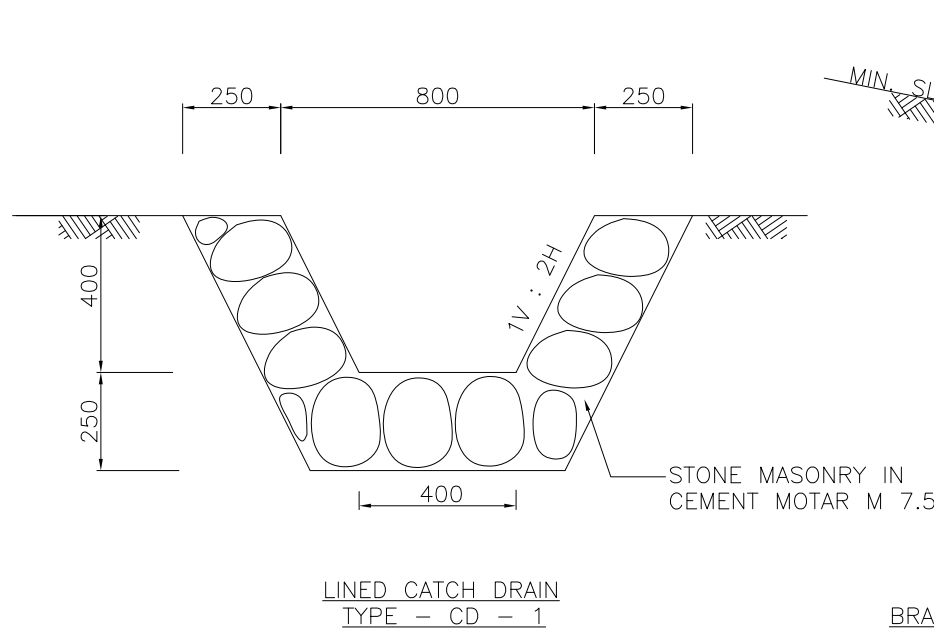
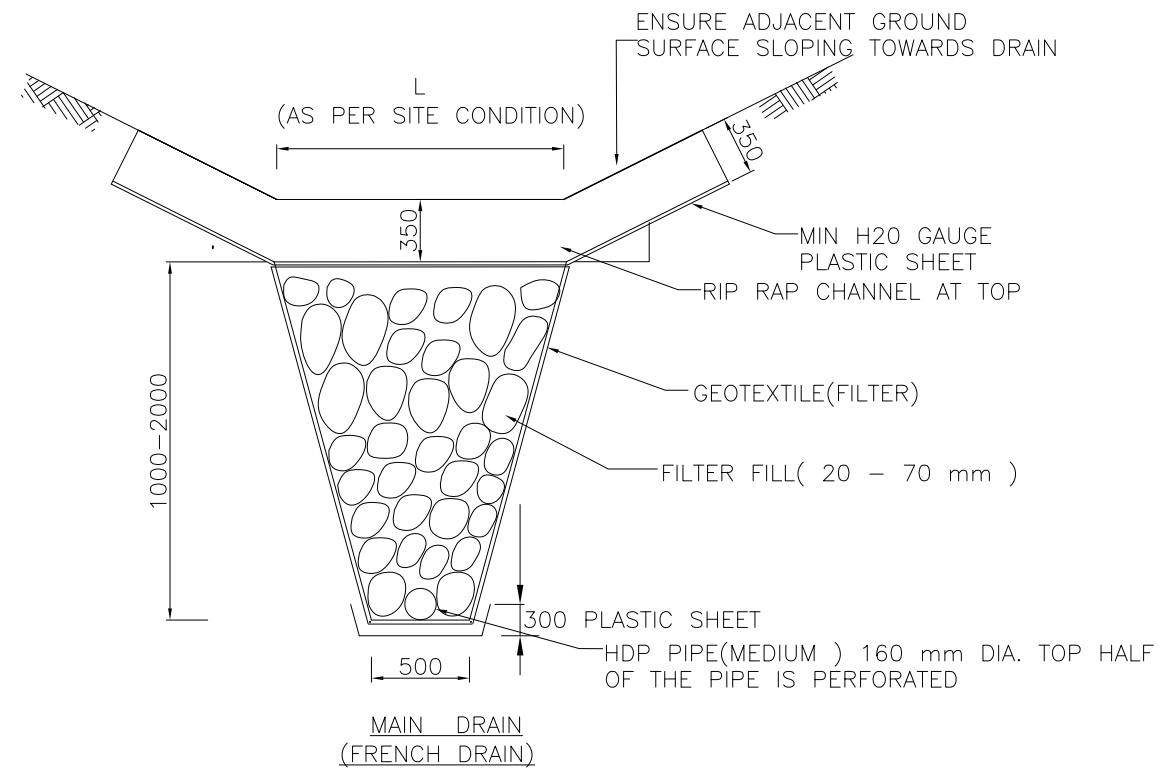
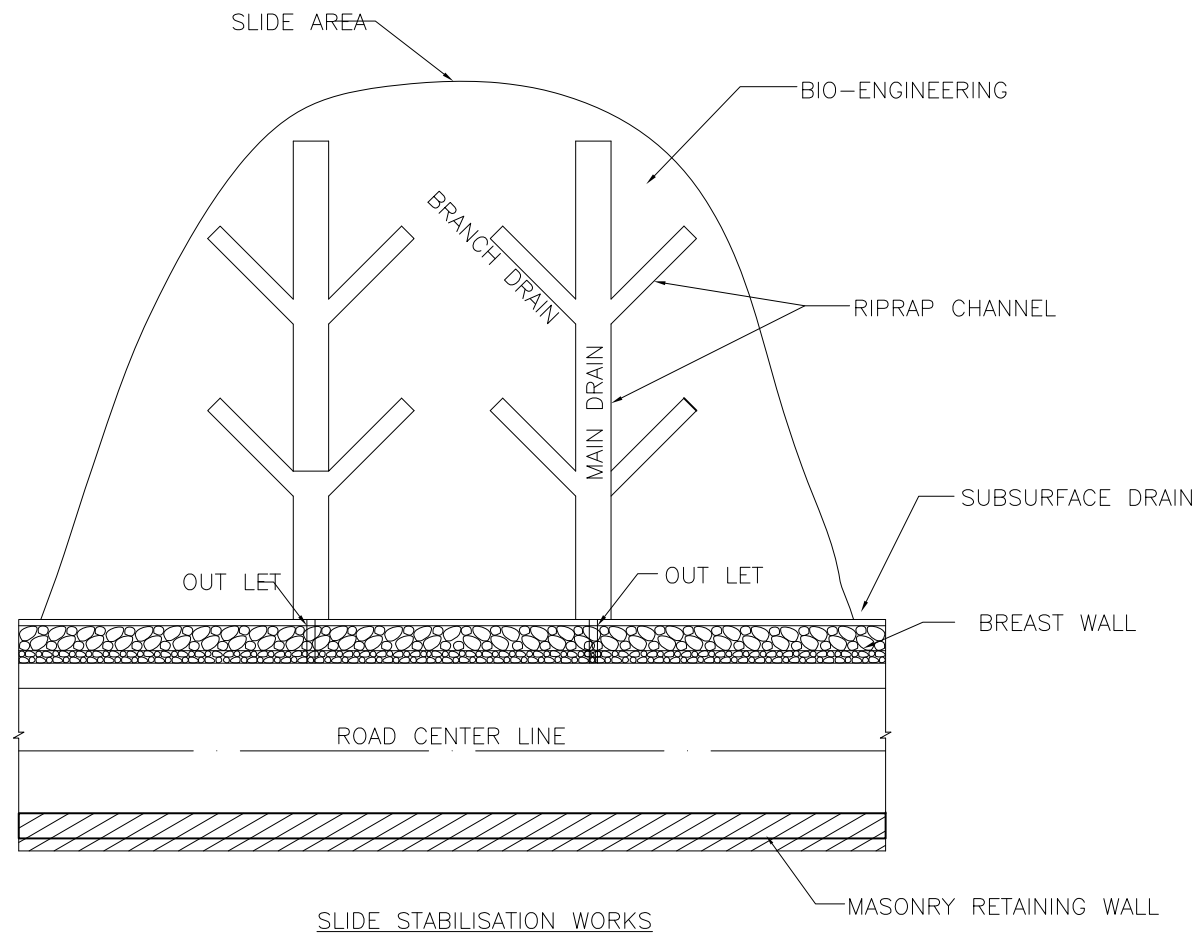

NOTE:

1. All dimensions are in mm unless noted otherwise.
2. Size and type of catch drain may vary as per site condition or as directed by the engineer.
3. Location of french drain should be along the gullies and top of the drain should be lower compared to adjacent ground level.
4. Outlet fall of drain should be located in such a way that water from outlet does not fall on the pavement.
5. Height of main/tributary subsurface drain may vary as per site condition.
6. The pipes shall be perforated by drilling minimum 50 holes per meter length on the upper half of the pipe in the staggered pattern uniformly distributed with a diameter of 3mm (minimum) to 6mm (maximum).

Government of Nepal Ministry of Physical Infrastructure & Transport Department of Roads			
STANDARD DRAWINGS FOR ROAD ELEMENTS			
LANDSLIDE STABILIZATION			
TYPICAL DRAWING			
	Recommended by	Approved by	SHEET. NO. 15
Signature	<i>Arjun Jung Thapa</i>	<i>Devendra Karki</i>	
	Arjun Jung Thapa	Devendra Karki	
Designation	Deputy Director General	Director General	

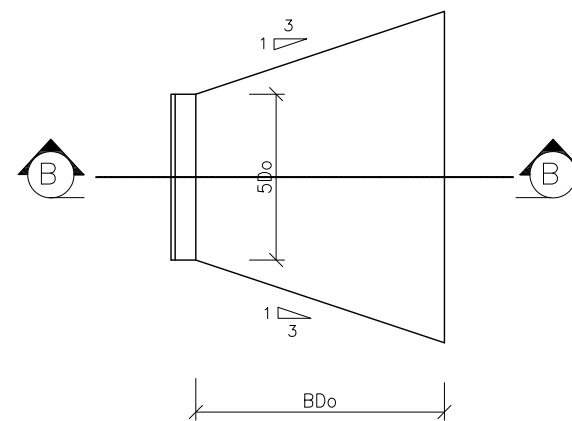
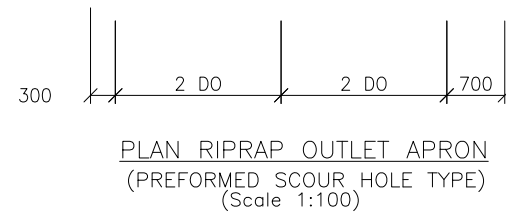
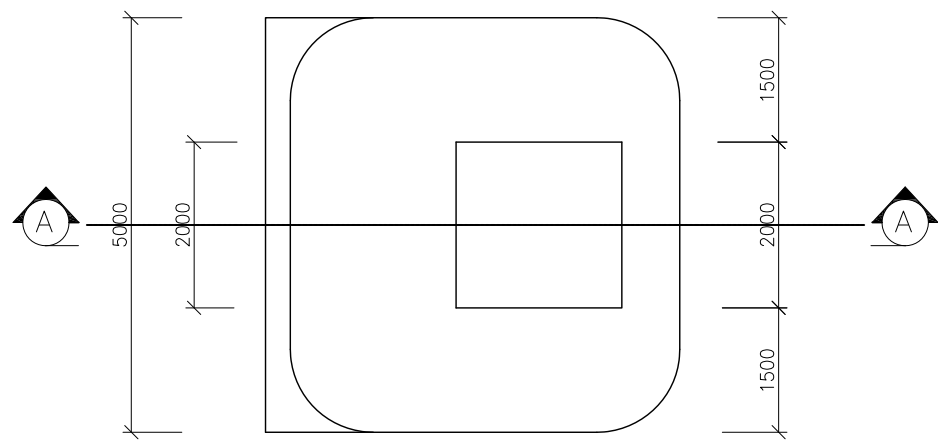

PLAN RIPRAP OUTLET APRON
(HORIZONTAL TYPE)
(Scale 1:100)

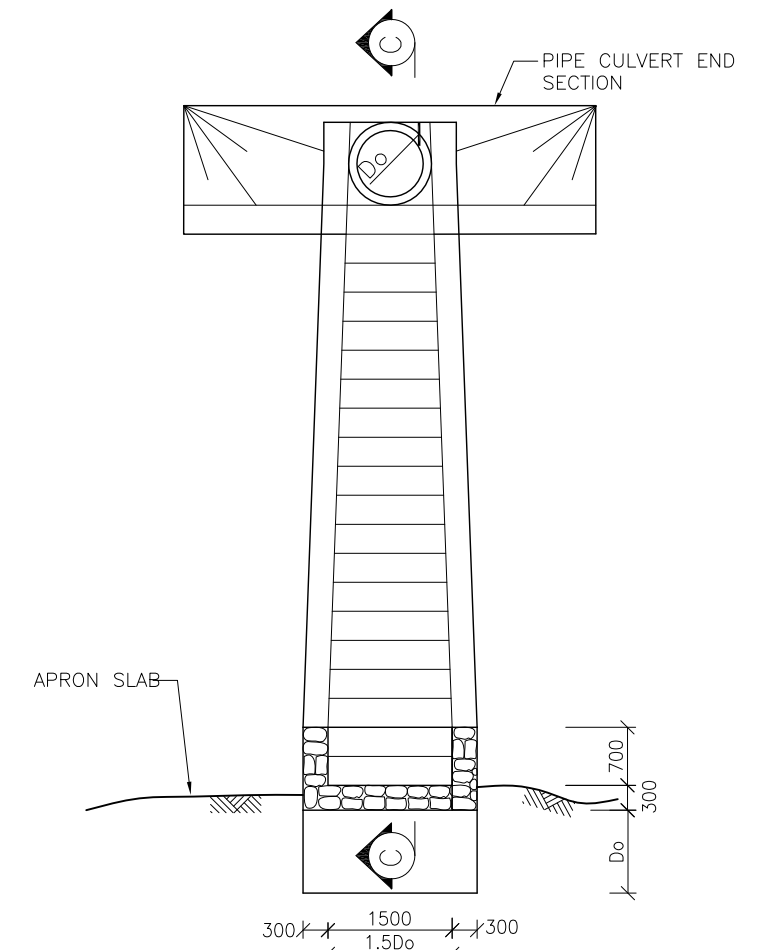

CHUTE DETAIL
(Scale 1:100)

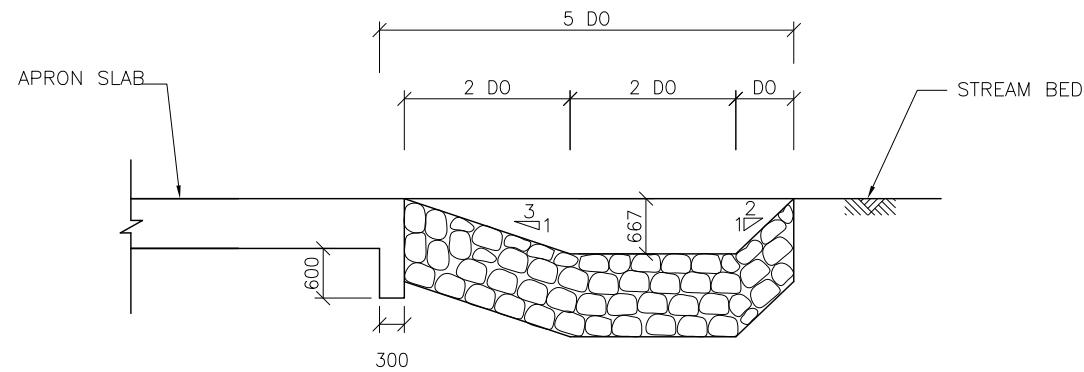

SECTION A-A
(Scale 1:100)

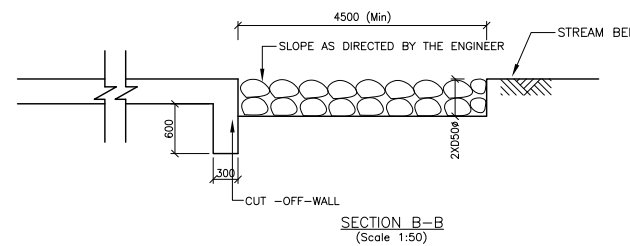

SECTION B-B
(Scale 1:50)

Do(M)	D5o(M) FOR PERFORMED SCOUR HOLE TYPE	D5o(M) FOR HORIZONTAL TYPE
0.60 φ	0.10	0.15
0.90 φ	0.12	0.20
1.20 φ	0.15	0.30
1.00 φ	0.20	0.40
1.5 φ	0.30	0.40
2.00 φ	0.40	0.45
2.50 φ	0.45	0.50
3.00 φ	0.50	0.75

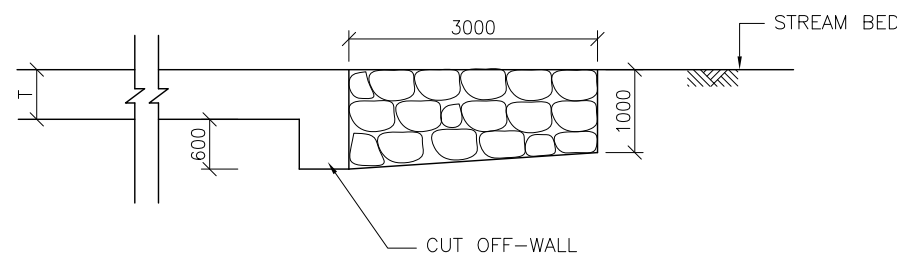

RIPRAP INLET APRON DETAIL
(Scale 1:100)

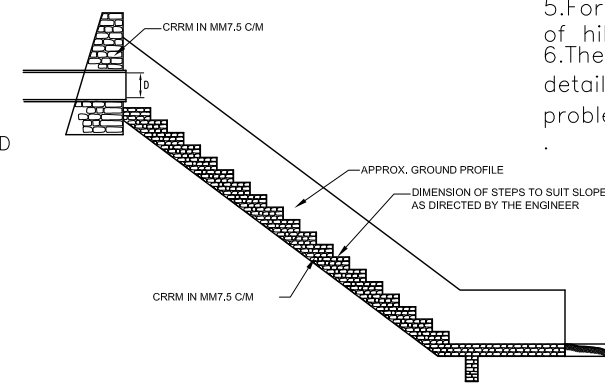

SECTION C-C
(SCALE 1:100)

Notes:-

1. Do represents clear span of culvert and D 50 for size of Riprap Stone.
2. Riprap outlet apron shall be provided as specified.
3. Riprap inlet apron shall be provided as specified.
4. Riprap outlet apron or chute shall be provided wherever required.
5. For section C-C refer drawing of pipe culvert of hilly area.
6. The dimensions shown here are indicative. For detailed design refer to "Roadside geotechnical problems: A practical Guide to their Solutions".

Government of Nepal Ministry of Physical Infrastructure & Transport Department of Roads			
STANDARD DRAWINGS FOR ROAD ELEMENTS			
RIPRAP APRONS AND CHUTE DETAILS			
TYPICAL DRAWINGS			
	Recommended by	Approved by	
Signature			SHEET. NO. 16
Designation	Deputy Director General	Director General	

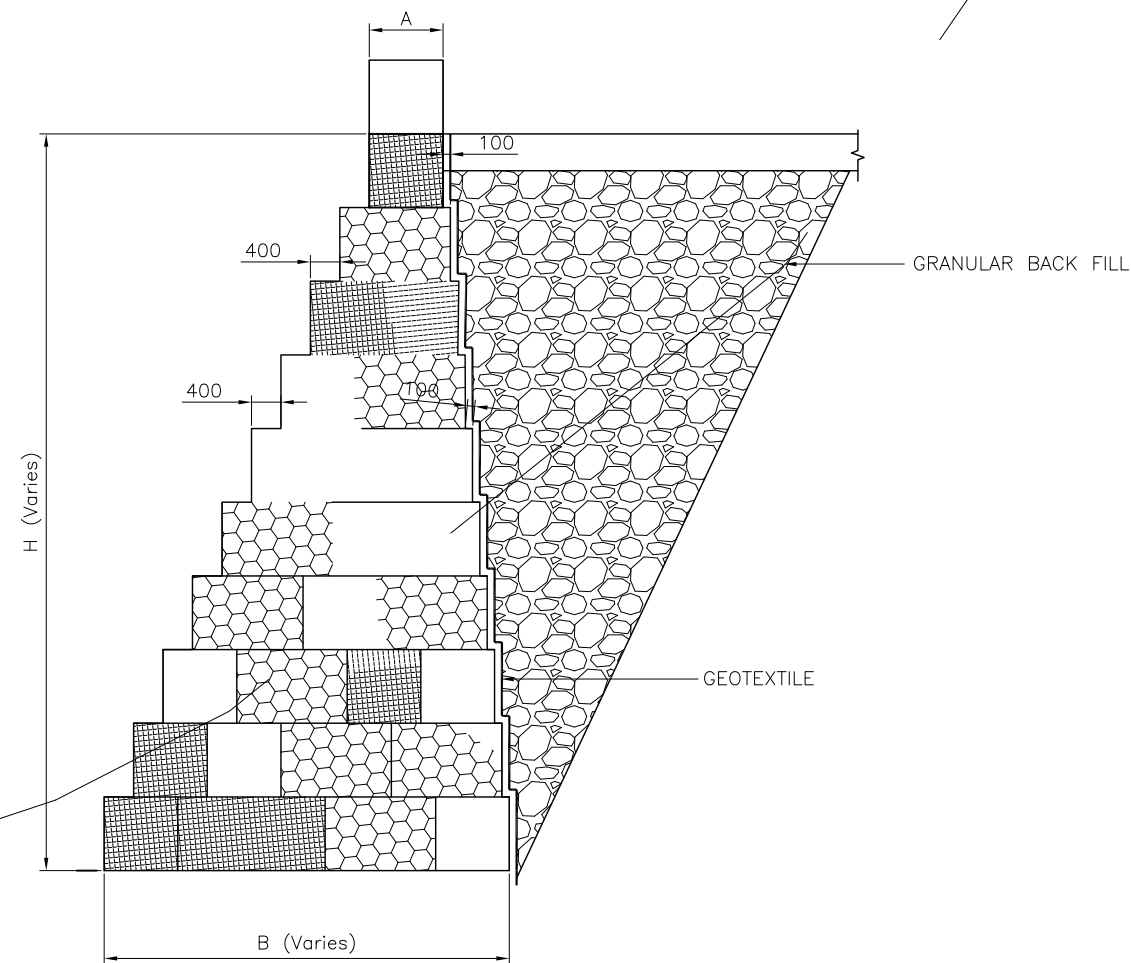

GRAVITY GABION WALL (Front Batter)

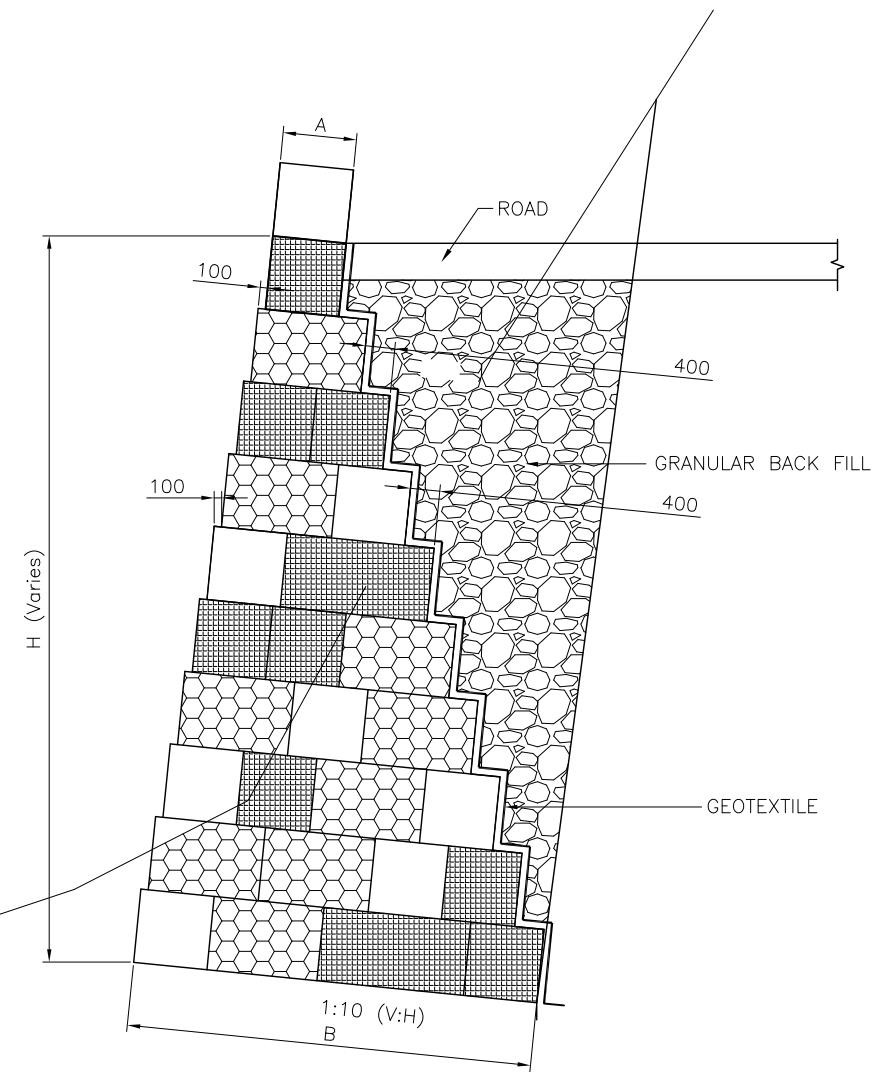

GRAVITY GABION WALL (Back Batter)

Detail for Semi Gravity Gabion walls

BASE WIDTHS AND TYPICAL GROUND PRESSURES ((T/m ²)								
Wall Height (m)		2	3	4	6	8	10	12
Front Batter	Base Width, m	1.5	2.0	2.5	3.5	4.5	5.5	6.5
	Ground pressure (T/m ²)	50	70	90	120	150	190	230
Back Batter	Base Width, m	1.5	2.0	2.55	3.5	4.5	5.5	6.5
	Ground pressure (T/m ²)	70	110	150	220	290	360	420

NOTES:

1. All dimensions are in mm except otherwise mentioned.
2. For wall height more than 6.0 m, and backfill slope angle greater than 20°, detailed design with soil investigation is to be done or as directed by the Engineer.
3. If space is available, slopping outside is preferred for valley side of the road.

Government of Nepal Ministry of Physical Infrastructure & Transport Department of Roads			
STANDARD DRAWINGS FOR ROAD ELEMENTS			
GABION RETAINING WALLS			
TYPICAL DRAWINGS			
	Recommended by	Approved by	SHEET. NO. 17
Signature			
	Arjun Jung Thapa	Devendra Karki	
Designation	Deputy Director General	Director General	

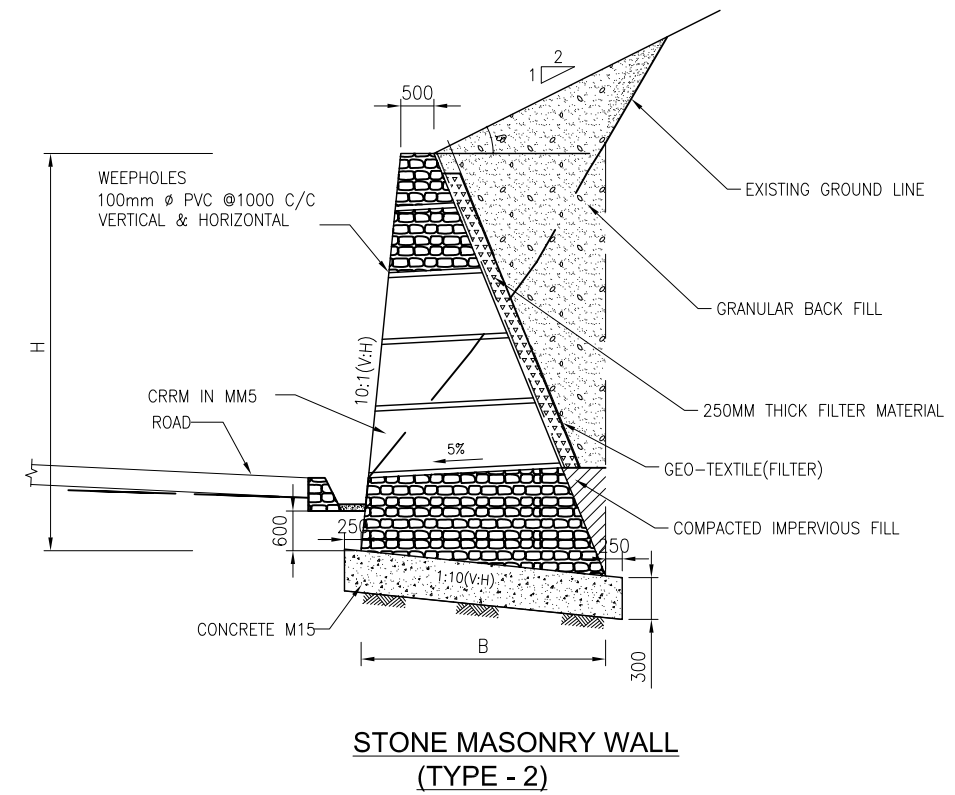
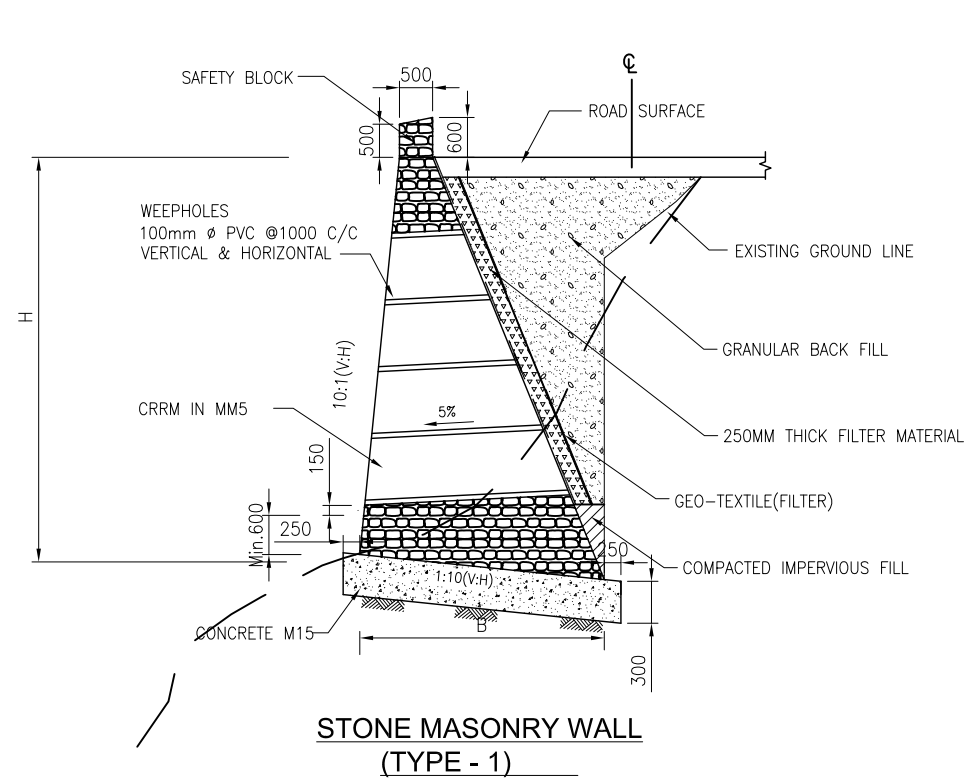

TYPE - 1

H (m)	Φ=40°				Φ=30°				Φ=24°			
	B (m)	FSS	FSO	Max. Toe Pressure (kN/m ²)	B (m)	FSS	FSO	Max. Toe Pressure (kN/m ²)	B (m)	FSS	FSO	Max. Toe Pressure (kN/m ²)
2	1.36	2.03	2.56	92.00	1.50	1.65	2.46	100.00				
3	2.00	2.23	2.66	129.90	2.18	1.84	2.58	140.00	2.38	1.69	2.58	144.20
4	2.61	2.37	2.74	165.30	2.83	1.95	2.63	178.50	3.08	1.73	2.62	183.80
5	3.20	2.44	2.76	200.90	3.47	2.01	2.66	220.50	3.78	1.79	2.65	221.90
6	3.80	2.51	2.80	235.10	4.12	2.07	2.70	252.30	4.47	1.83	2.68	259.70
7	4.38	2.55	2.80	269.80	4.74	2.10	2.71	289.72	5.15	1.86	2.69	297.50
8	4.95	2.58	2.82	304.70	5.36	2.13	2.71	326.70	5.83	1.89	2.70	334.90
9	5.55	2.62	2.85	337.80	5.98	2.14	2.72	363.40	6.51	1.92	2.71	369.70
10	6.10	2.62	2.83	373.20	6.60	2.16	2.73	400.0	7.18	1.92	2.73	408.40

TYPE - 2

β = 26.5°

H (m)	Φ=40°				Φ=30°			
	B (m)	FSS	FSO	Max. Toe Pressure (kN/m ²)	B (m)	FSS	FSO	Max. Toe Pressure (kN/m ²)
2					1.27	1.55	2.38	95.90
3	1.68	2.21	2.60	123.50	1.95	1.51	2.38	145.40
4	2.31	2.13	2.60	164.20	2.61	1.49	2.37	193.10
5	3.00	2.13	2.70	200.70	3.27	1.49	2.37	241.30
6	3.54	2.06	2.60	245.40	3.93	1.48	2.37	289.40
7	4.14	2.04	2.59	286.60	4.58	1.48	2.36	339.00
8	4.75	2.03	2.59	327.10	5.32	1.50	2.43	387.70
9	5.35	2.02	2.58	368.20	6.00	1.50	2.44	436.50
10	5.95	2.01	2.58	409.20	6.65	1.50	2.43	484.30

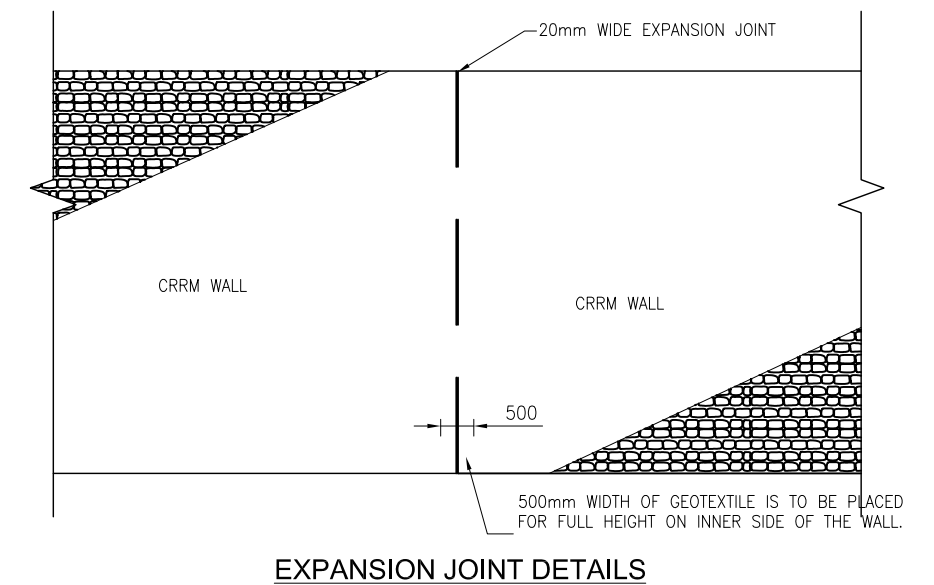

NOTES :

1. Ensure rock at foundation for toe pressure >250 kN/m²
2. Expansion Joint is to be provided at a maximum distance of 10.0 m C/C or as directed by the Engineer.
3. FSS means factor of safety against sliding and FSO means factor of safety against overturning.
4. All dimensions are in mm except otherwise mentioned.
5. Safety blocks to be provided where the wall height is more than 3.0 m.

Government of Nepal Ministry of Physical Infrastructure & Transport Department of Roads			
STANDARD DRAWINGS FOR ROAD ELEMENTS			
STONE MASONRY RETAINING WALLS			
TYPICAL DRAWINGS			
Recommended by	Approved by		SHEET. NO. 18
Signature	Signature		
Designation	Designation		
Deputy Director General	Director General		

DETAILS FOR Dry Masonry Wall Type 1

Height (m)	Base width(B) (m)	Ground Pressure (T/m ²)
1.00	0.90	2.00
2.00	1.30	3.50
3.00	1.70	5.50
4.00	2.10	7.50

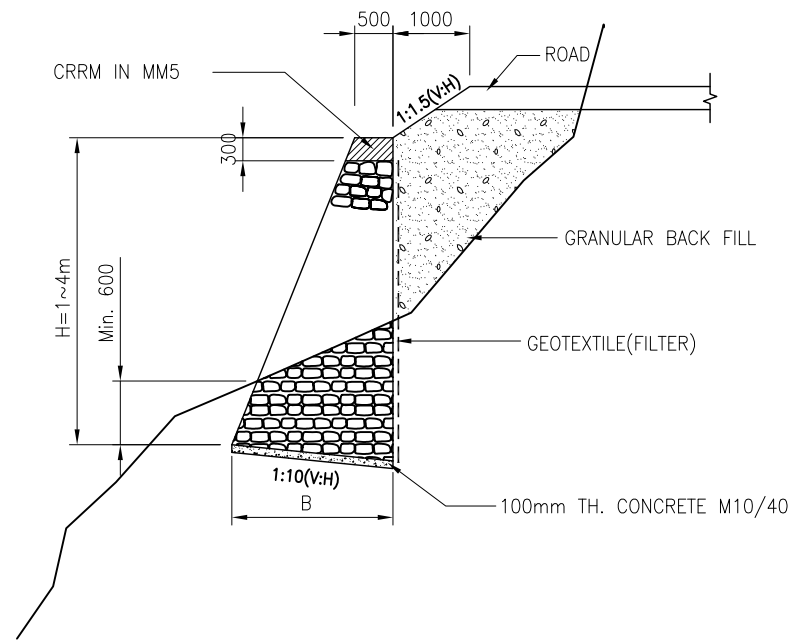

DRY STONE MASONRY WALL
(Type - 1)

DETAILS FOR Dry Masonry Wall Type 2

Height (m)	Base width (m)	Ground Pressure (T/m ²)
1.00	1.00	2.50
2.00	1.50	4.50
3.00	2.00	6.50
4.00	2.50	8.50

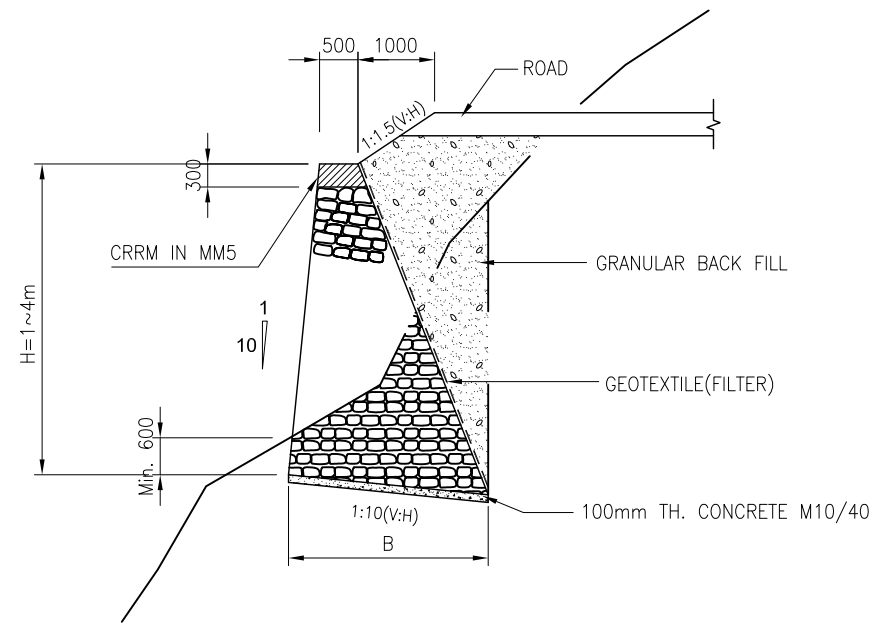

DRY STONE MASONRY WALL
(Type - 2)

NOTES :

- Expansion Joint is to be provided at a maximum distance of 10.0 m c/c or as directed by the Engineer.
- All dimensions are in mm except otherwise mentioned.

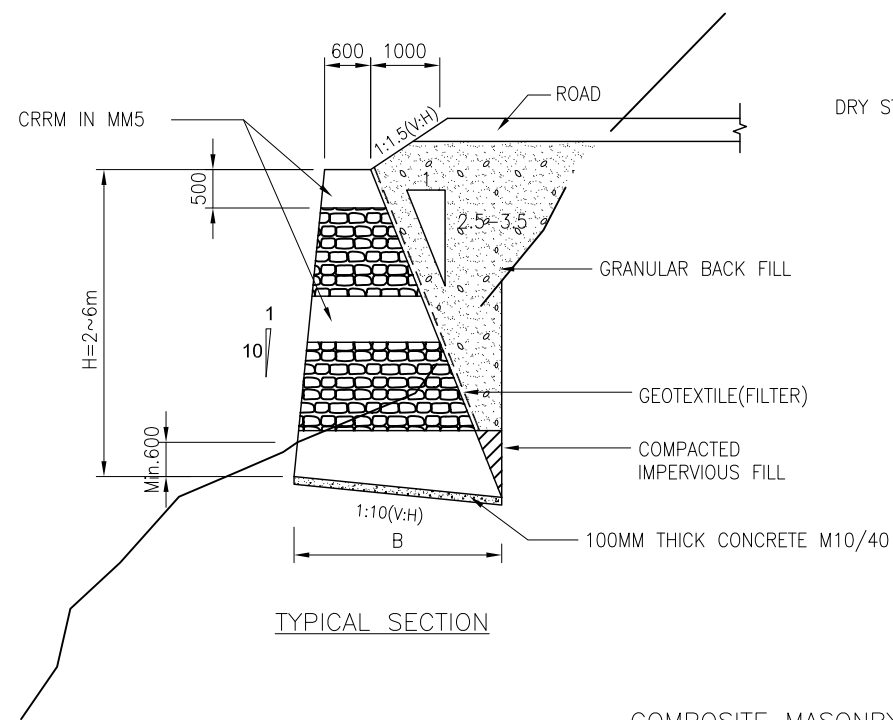

TYPICAL SECTION

COMPOSITE MASONRY WALL

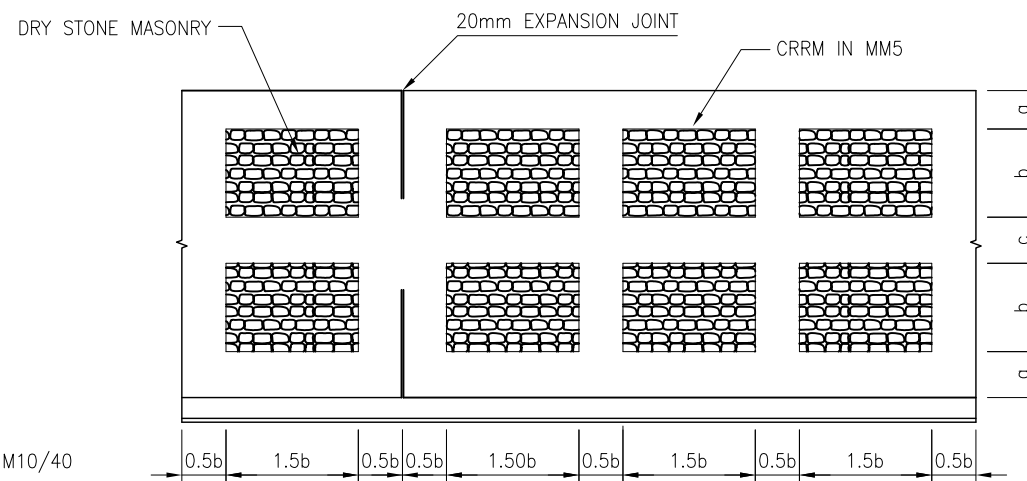

ELEVATION SHOWING
TYPICAL LAYOUT DETAIL

SCALE (m)



PANNEL LAYOUT DIMENSIONS

Height (m)	Breadth (m)	Dimension (m)		
		a	b	c
2.00	1.2	0.60	0.80	-
3.00	1.8	0.75	1.50	-
4.00	2.4	0.60	1.15	0.50
5.00	3.0	0.60	1.40	1.00
6.00	3.6	0.75	1.75	1.00



Government of Nepal
Ministry of Physical Infrastructure & Transport
Department of Roads

STANDARD DRAWINGS FOR ROAD ELEMENTS

DRY AND COMPOSITE MASONRY RETAINING WALLS

TYPICAL DRAWINGS

Signature	Recommended by	Approved by	SHEET. NO. 19
	Arjun Jung Thapa	Devendra Karki	
	Deputy Director General	Director General	

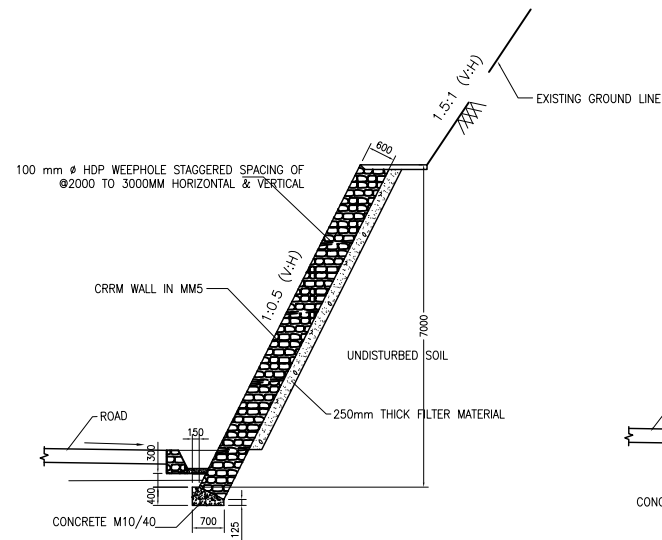

CRRM REVETMENT
5.00 - 7.00 m HEIGHT

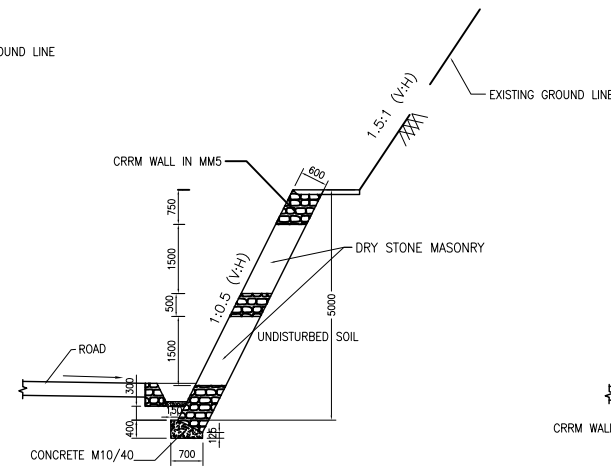

COMPOSITE REVETMENT
3.00-5.00 m HEIGHT

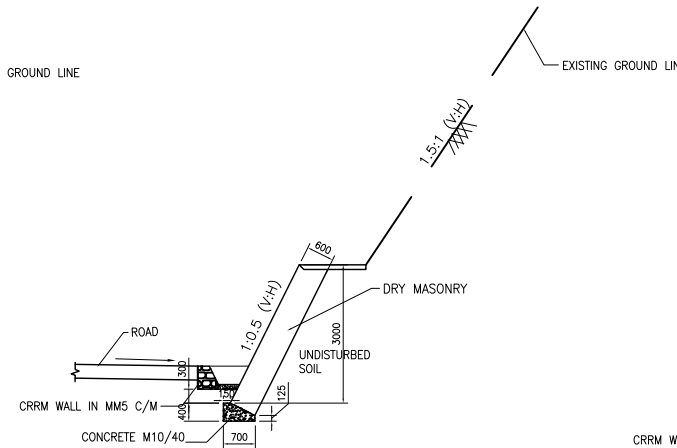

DRY REVETMENT
UP TO 3.00 m HEIGHT

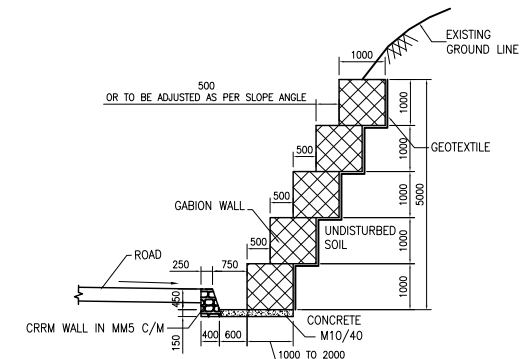

GABION TYPE
UP TO 5.00 m HEIGHT

REVETMENTS

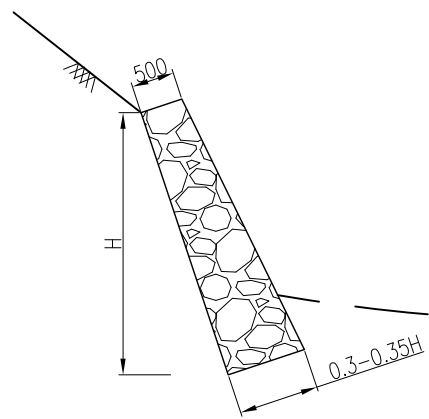

Dry Masonry

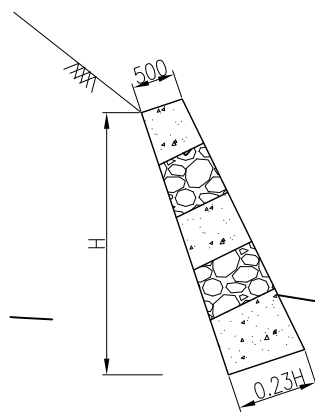

Banded Masonry

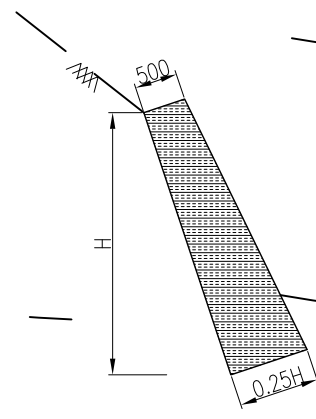

Cement Masonry

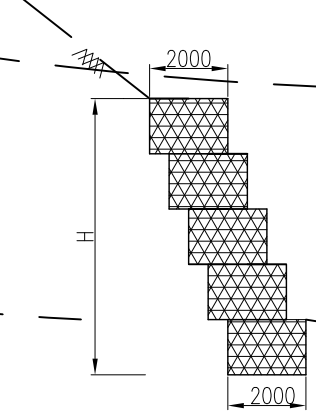

Gabion

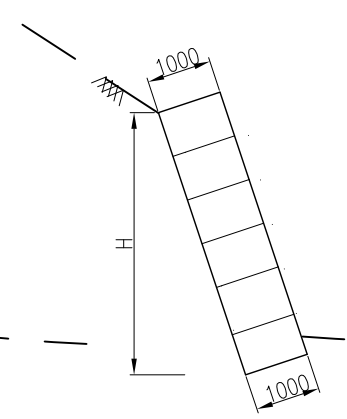

Drum Wall

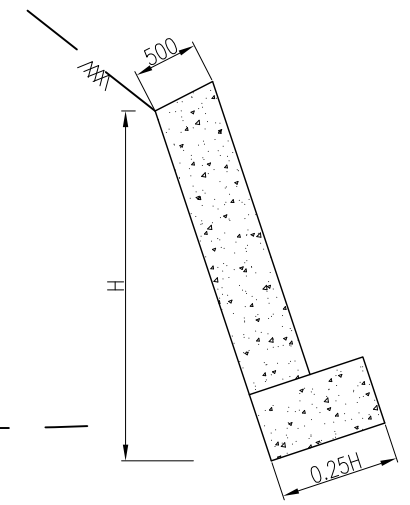

Concrete

BREAST WALLS

SCALE (m)

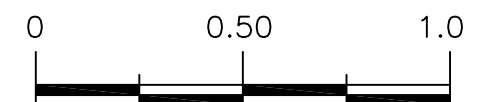

Types	Dry Masonry	Banded Masonry	Cement Masonry	Gabion	Drum Wall	Concrete
Top width (m)	0.5	0.5	0.5	2.0	1.0	0.5
Base width	0.3-0.35H	0.23H	0.25H	2.0	1.0	0.25H
Front batter (V:H)	Varies	Varies	Varies	Varies	Varies	Varies
Back batter (V:H)	3:1-5:1	3:1	3:1	3:1-5:1	3:1	3:1
Foundation dip (V:H)	1:3-1:5	1:3	1:3	1:5	1:3	1:3
Foundation depth (V:H)	0.5	0.5	0.5	0.5-1.0	0.25	0.5
Height range (m)	3.0-6.0	3.0-6.0	1.0-8.0	1.0-6.0	1.0-2.2	1.0-12.0
Hill slope angle*	35°-60°	35°-60°	35°-70°	35°-60°	15°-35°	35°-70°

NOTES:

- All dimensions are in mm except otherwise mentioned.
- Revetment structures should be used for protection works only, i.e for zero earth pressure case.

Government of Nepal
Ministry of Physical Infrastructure & Transport
Department of Roads

STANDARD DRAWINGS FOR ROAD ELEMENTS

REVETMENT AND BREAST WALLS

TYPICAL DRAWINGS

Recommended by	Approved by	SHEET. NO. 20
Signature	Signature	
Designation	Designation	

Arjun Jung Thapa
Deputy Director General

Devendra Karki
Director General

TABLE FOR DIMENSIONS OF THE R.C.C WALLS WITH SURCHARGE LOAD OF $2T/m$ DUE TO ROAD TRAFFIC

H m	B m	T m	T1 m	T2 m	X m	Y m	Maximum Pressure T/m ²
2	1.50	0.40	0.20	0.50	0.40	0.70	8.40
3	2.14	0.40	0.20	0.60	0.40	1.34	12.30
4	2.60	0.50	0.20	0.60	0.60	1.50	15.00
5	3.00	0.50	0.20	0.60	0.85	1.65	17.25
6	3.60	0.60	0.20	0.60	0.87	2.13	21.38
7	4.20	0.72	0.20	0.60	0.90	2.58	24.00
8	4.80	0.85	0.20	0.60	1.00	2.95	26.60
9	5.40	1.00	0.20	0.70	1.00	3.40	30.40
10	6.00	1.10	0.20	0.80	1.00	3.90	34.20

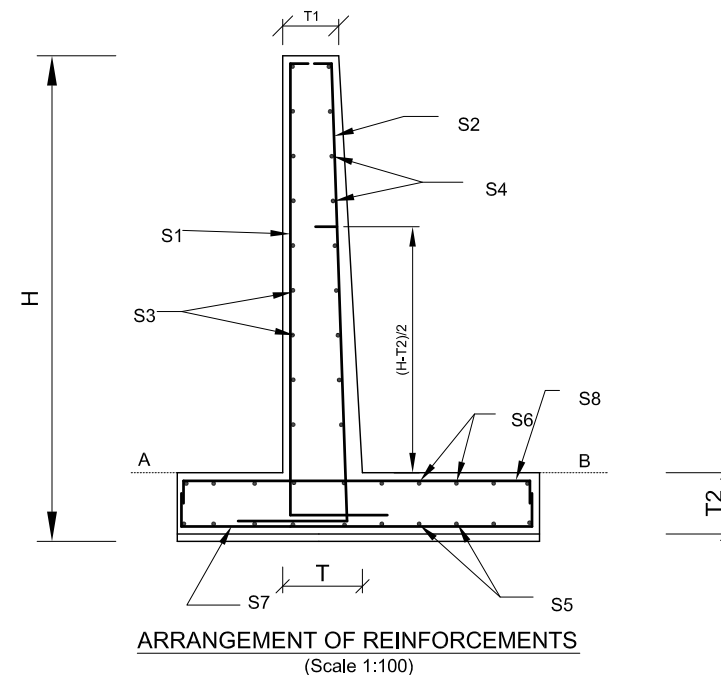
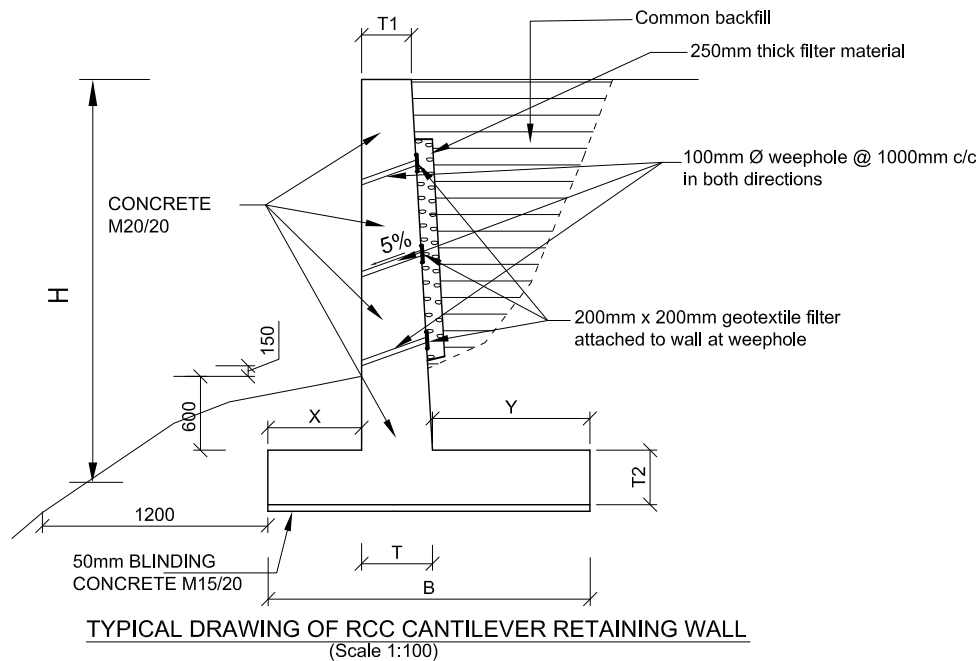





TABLE FOR REINFORCEMENT

HEIGHT (H) m	HIGH YIELD STEEL REINFORCEMENT															
	S1		S2		S3		S4		S5		S6		S7		S8	
	Ø mm	Spacing mm	Ø mm	Spacing mm	Ø mm	Spacing mm	Ø mm	Spacing mm	Ø mm	Spacing mm	Ø mm	Spacing mm	Ø mm	Spacing mm	Ø mm	Spacing mm
2	12	200	10	160	12	200	12	200	10	150	10	150	12	200	12	200
3	12	200	12	130	12	200	12	200	12	180	12	180	12	200	12	200
4	12	200	16	150	12	200	12	200	12	180	12	180	12	200	12	160
5	12	200	16	110	12	200	12	200	12	180	12	180	12	200	16	180
6	12	180	20	135	12	180	12	180	12	160	12	160	12	180	16	105
7	12	180	20	100	12	180	12	180	12	160	12	160	12	150	20	100
8	16	200	20	90	12	170	12	170	12	160	12	160	16	190	25	110
9	16	200	25	119	12	150	12	150	12	160	12	160	16	190	25	105
10	16	200	25	100	12	140	12	140	12	140	12	140	16	180	25	100

NOTES :

1. Wall height is to be modified as per actual site condition or as directed by the Engineer.
2. Wall height for more than 6.0 m, soil investigation is to be done or as directed by the Engineer.
3. Expansion Joint is to be provided maximum at a distance of 30.0 m C/C .It should be located, wherever possible, at every major changes in wall height or as directed by the Engineer.
4. Lowest weep hole should not be more than 200mm above final ground level at the toe of wall or as directed by the Engineer.
5. Concrete mix used for structure is M20/20
6. Concrete mix used for blinding is M15/20
7. Curtail the alternate bar S2 at a distance of $(H-T2)/2$ from level A
8. Geotextile in wall back side (where expansion joint is located) is to be provided throughout height to control soil erosion from back side.
9. Reinforcements for intermediate height may be worked out by interpolation.
10. If the maximum pressure exceeds the allowable soil bearing capacity, increase the base width so that pressure falls within the allowable limits.
11. The clear cover of concrete shall be 50mm
12. Others not mentioned shall be in accordance with the specifications and special provisions.

 Government of Nepal Ministry of Physical Infrastructure & Transport Department of Roads			
STANDARD DRAWINGS FOR ROAD ELEMENTS			
RCC CANTILEVER RETAINING WALL			
TYPICAL DRAWINGS			
	Recommended by	Approved by	SHEET. NO. 21
Signature			
	Arjun Jung Thapa	Devendra Karki	
Designation	Deputy Director General	Director General	

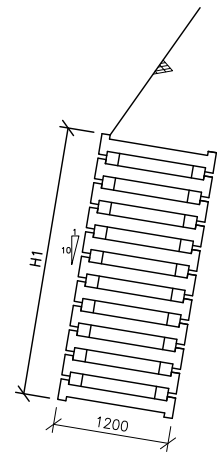

TYPE 1 CRIB WALL

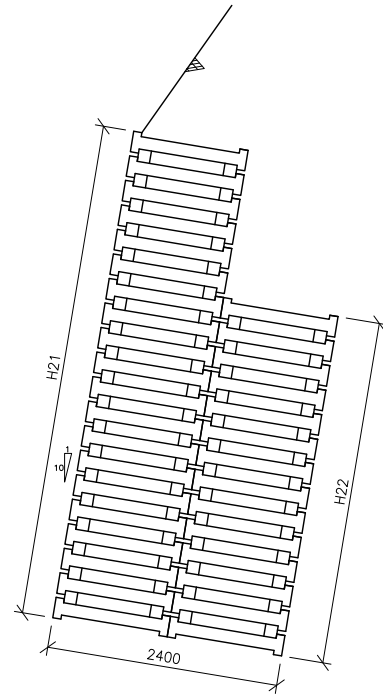

TYPE 3 CRIB WALL

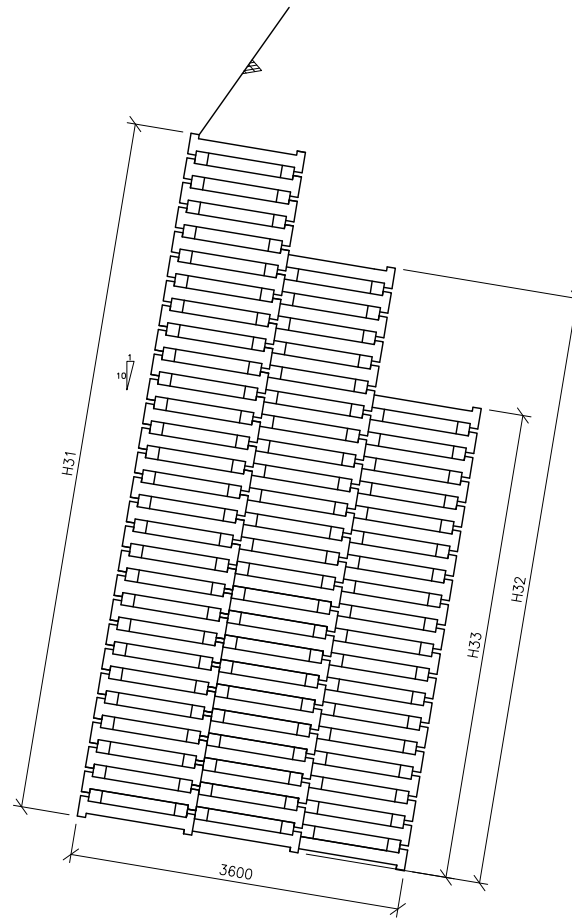

TYPE 3 CRIB WALL

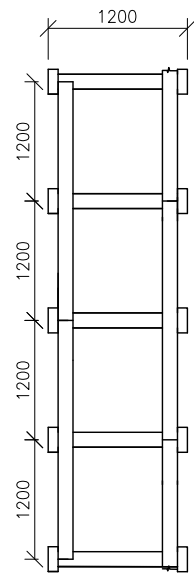

PLAN TYPE 1

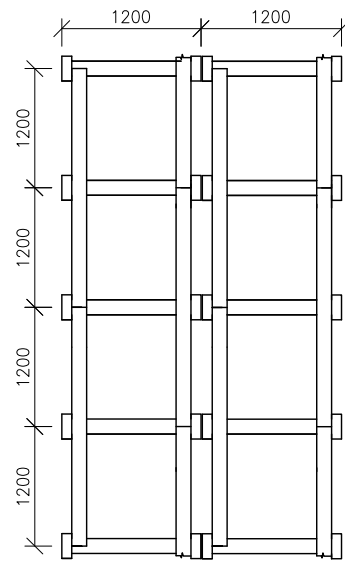

PLAN TYPE 2

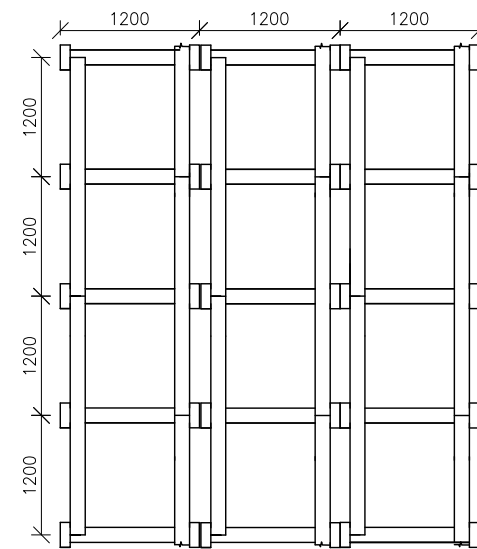

PLAN TYPE 3

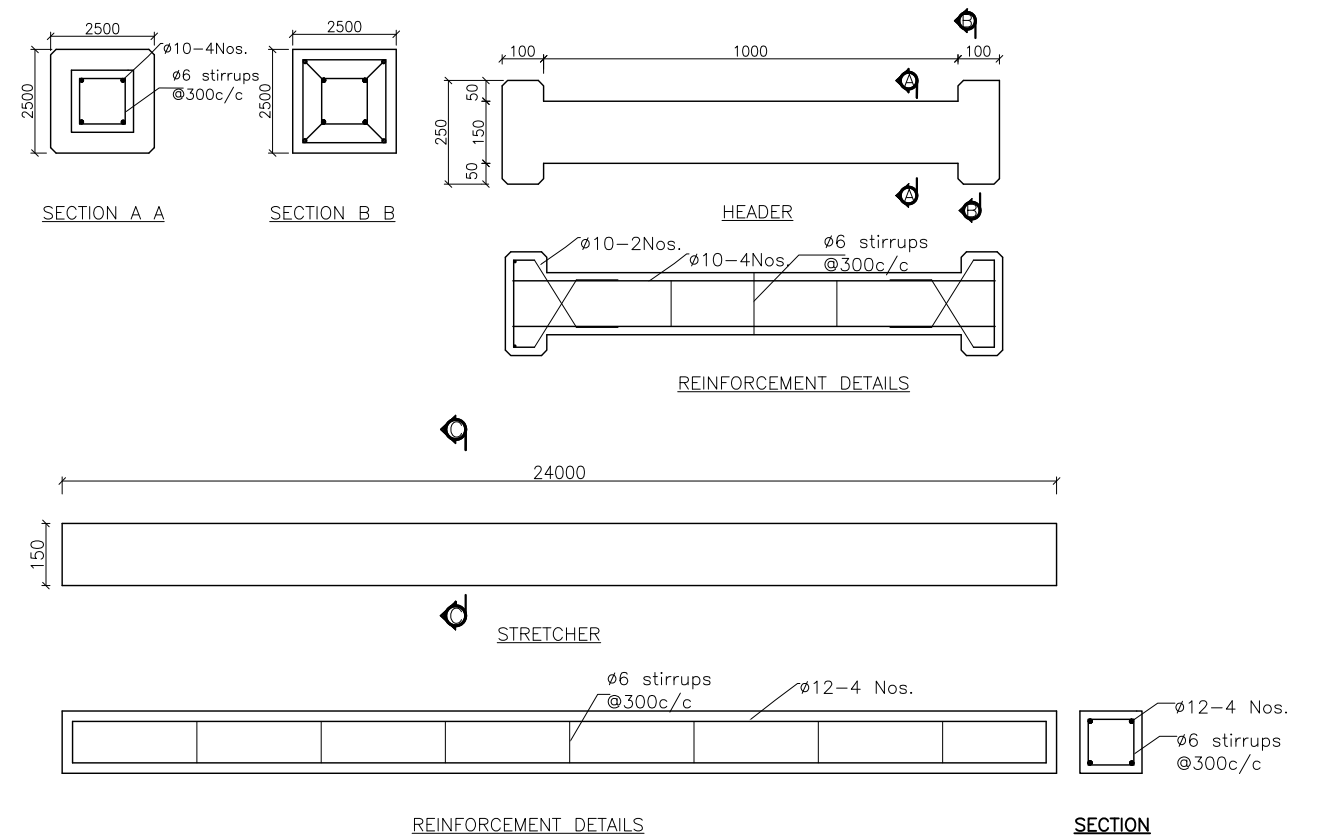

CRIB WALLS OF DIFFERENT HEIGHTS

Type	Hmax (m)	B (m)
H1	3.00	1.20
H21	5.50	2.20
H22	4.00	
H31	8.30	3.15
H32	7.20	
H33	5.30	

NOTE:

- All dimensions are in mm unless stated otherwise.
- The core shall be filled with granular materials.
- This wall can resist some settlement and deformation.
- This is a guidance only. The dimensions of precast members may vary as per the requirements.
- This standard shall be applicable up to 8 m height.
- Concrete M 25.
- Refer Roadside Geotechnical problems: A Guide to Their Solutions. Published by Department of Roads, May 2009.

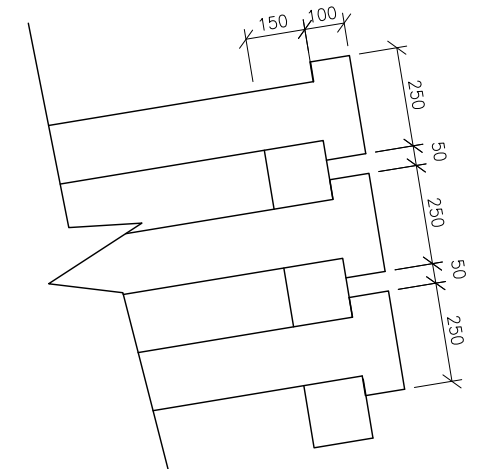

DETAIL A

Government of Nepal Ministry of Physical Infrastructure & Transport Department of Roads			
STANDARD DRAWINGS FOR ROAD ELEMENTS			
CRIB WALL			
TYPICAL DRAWINGS			
Recommended by	Approved by		SHEET. NO. 22
Signature	Signature		
Arjun Jung Thapa	Devendra Karli		
Designation	Deputy Director General	Director General	

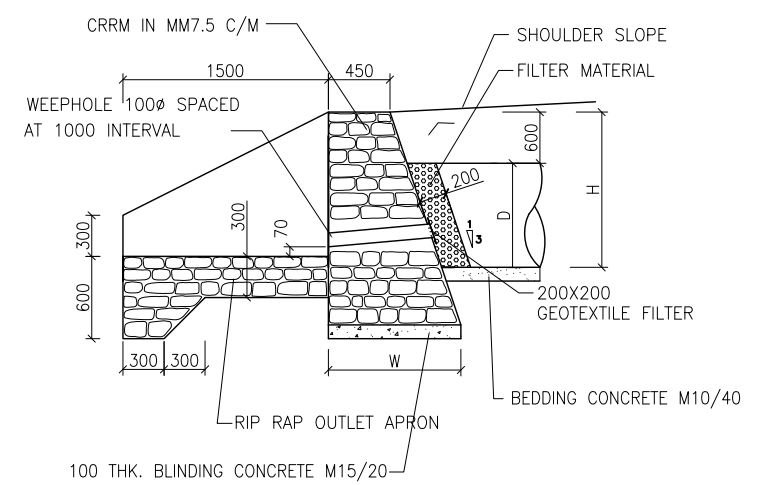
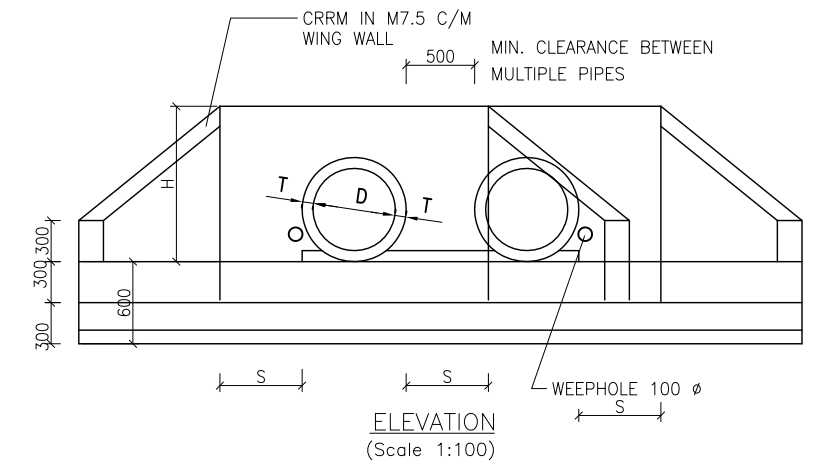
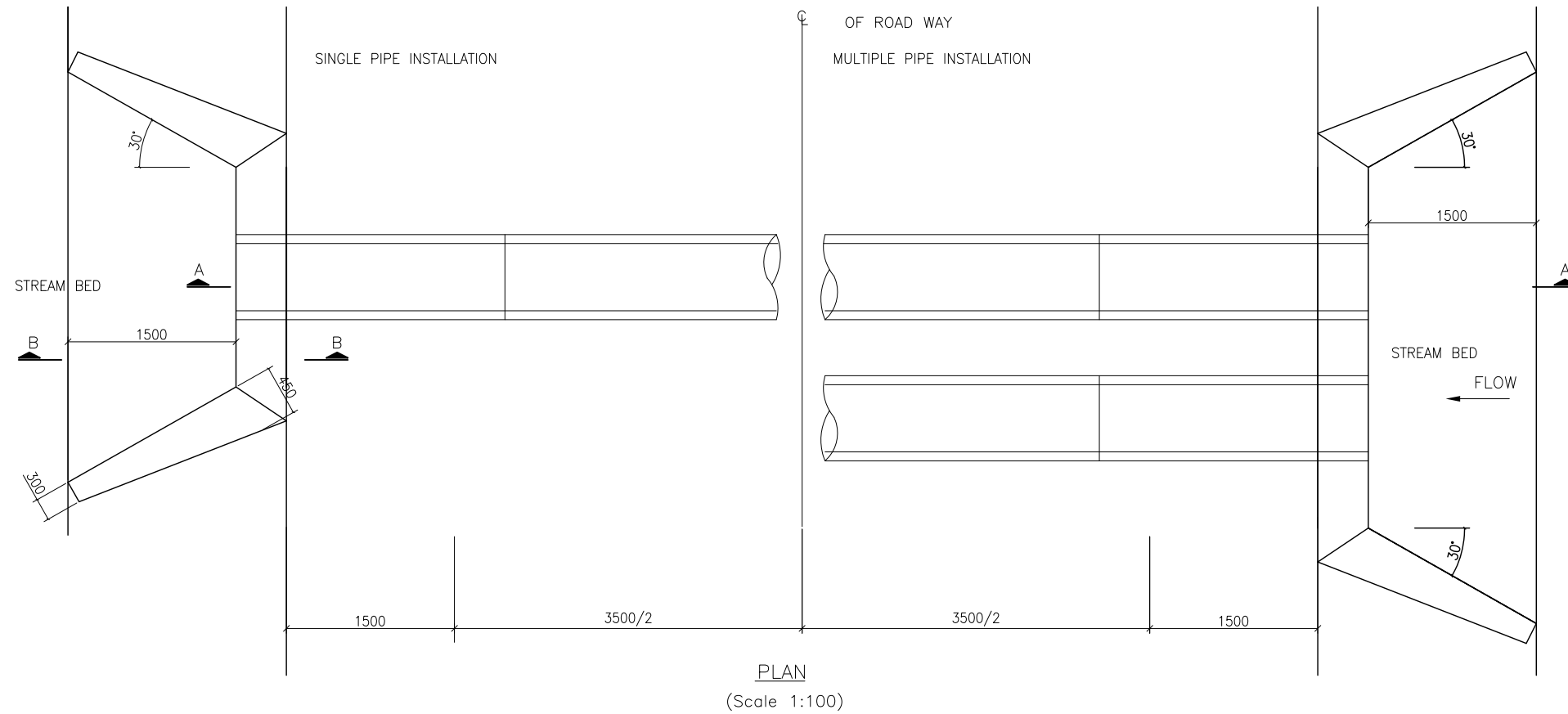

MASONRY END SECTION			
DIMENSIONS			
D	H	W	S
900	1300	890	900
1200	1630	890	1200

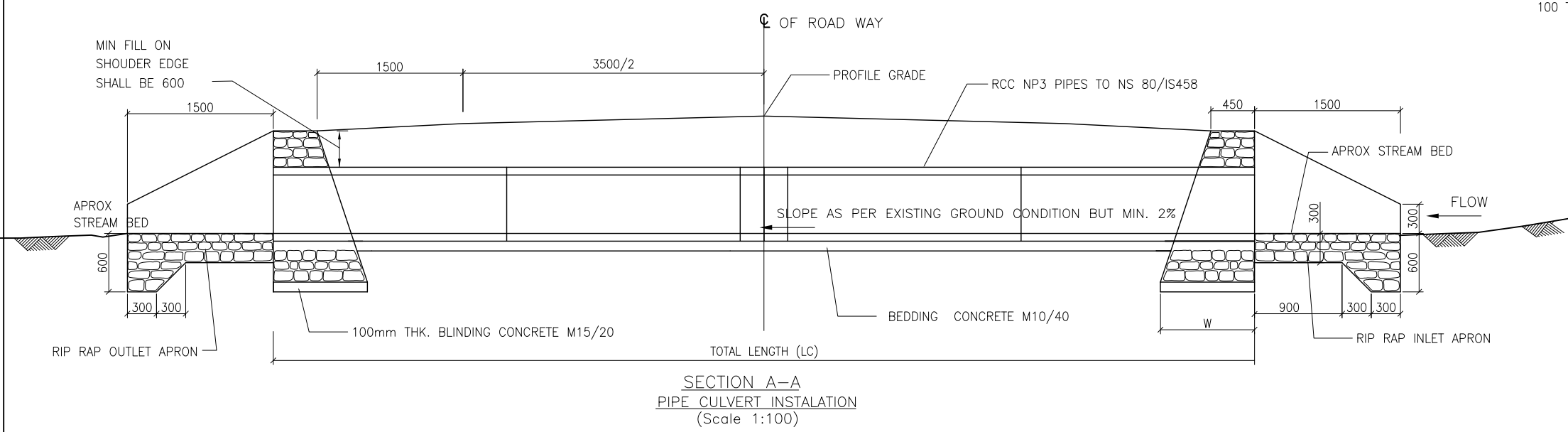

NOTES:

1. All work in accordance with standard specification and special provision
2. Length of the culvert (LC) shall be as per the Drawings or as directed by the Engineer.
3. Dimension of the wing wall will vary as per site condition which should be as directed by the Engineer.
4. Top of head wall must be flushed with the formation level.

Government of Nepal
Ministry of Physical Infrastructure & Transport
Department of Roads

STANDARD DRAWINGS FOR ROAD ELEMENTS

PIPE CULVERTS FOR PLAIN AREA

TYPICAL DRAWINGS

Recommended by	Approved by	SHEET. NO. 23
Signature	Signature	
Designation	Designation	

Arjun Jung Thapa
Deputy Director General

Devendra Karki
Director General

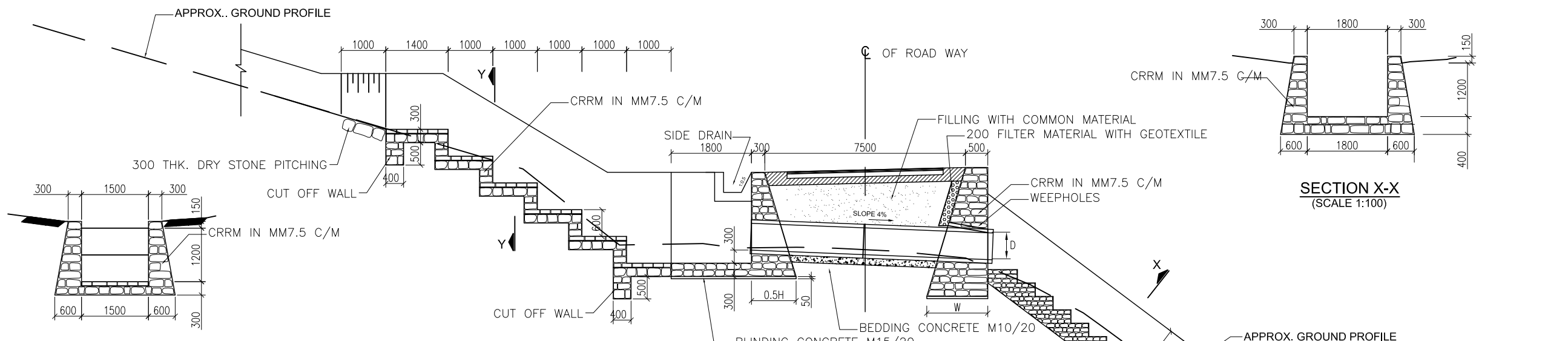

TYPICAL L-SECTION WITH INLET OUTLET STRUCTURE IN HILLY TERRAIN
(FOR ONE PIPE P.C.)
(SCALE 1:100)

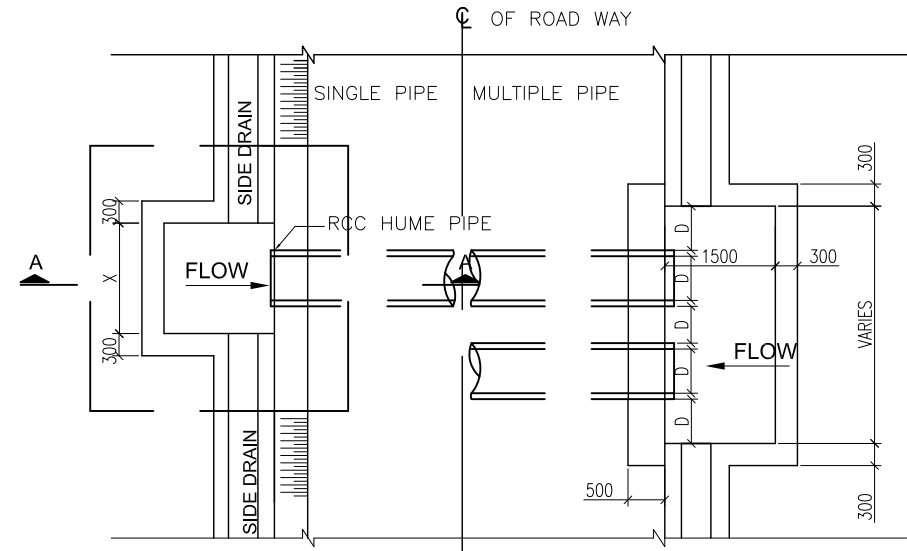

PLAN
(SCALE 1:100)

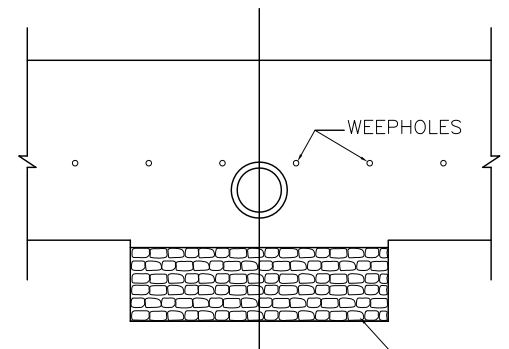

ELEVATION
(SCALE 1:100)

NOTE:
FOR THE DETAILS OF APRONS REFER TO THE
DRAWINGS OF RIPRAP APRONS AND
CHUTES.

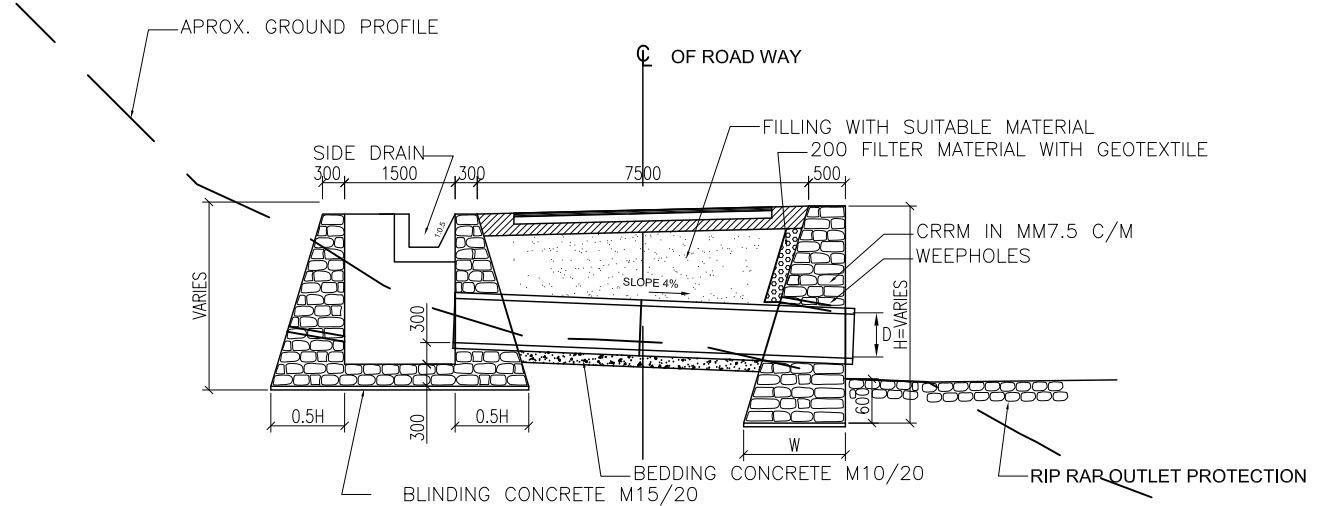

SECTION A-A
(FOR ROLLING TERRAIN)
(SCALE 1:100)

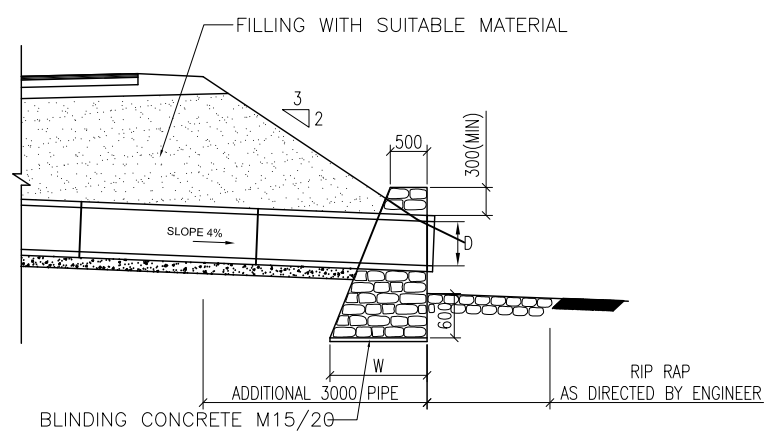

SECTION A-A : ALTERNATIVE OUTLET
(SCALE 1:100)

INTERNAL DIA. OF PIPE (mm)	X(m)	H(m)	W(m)
1X900	1.50	1.70	1.20
1X1200	1.50	2.00	1.50

Government of Nepal
Ministry of Physical Infrastructure & Transport
Department of Roads

STANDARD DRAWINGS FOR ROAD ELEMENTS

PIPE CULVERTS FOR HILLY AREA

TYPICAL DRAWINGS

Recommended by	Approved by	SHEET. NO. 24
Signature	Signature	
Designation	Designation	

Deputy Director General Director General

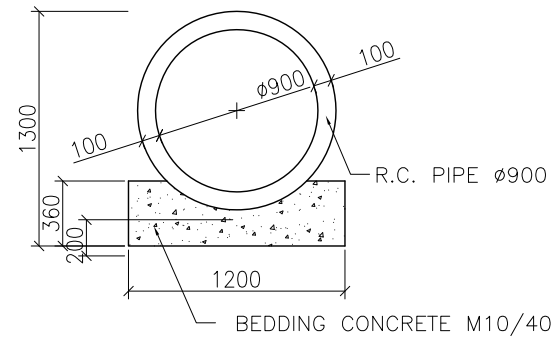

PIPE CULVERT (Ø900)

SCALE B

WORK QUANTITIES (PER 10.0m)

ITEM	UNIT	QUANTITY	REMARKS
R.C. PIPE (Ø900)	m	10.00	NP3
CONCRETE M10/40	m ³	3.46	
FORM WORK	m ²	7.20	
EXCAVATION	m ³	4.32	

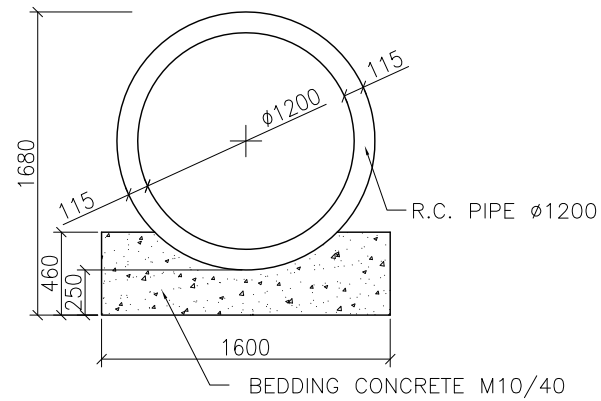

PIPE CULVERT (Ø1200)

SCALE B

WORK QUANTITIES (PER 10.0m)

ITEM	UNIT	QUANTITY	REMARKS
R.C. PIPE (Ø1200)	m	10.00	NP3
CONCRETE M10/40	m ³	5.89	
FORM WORK	m ²	9.20	
EXCAVATION	m ³	7.36	

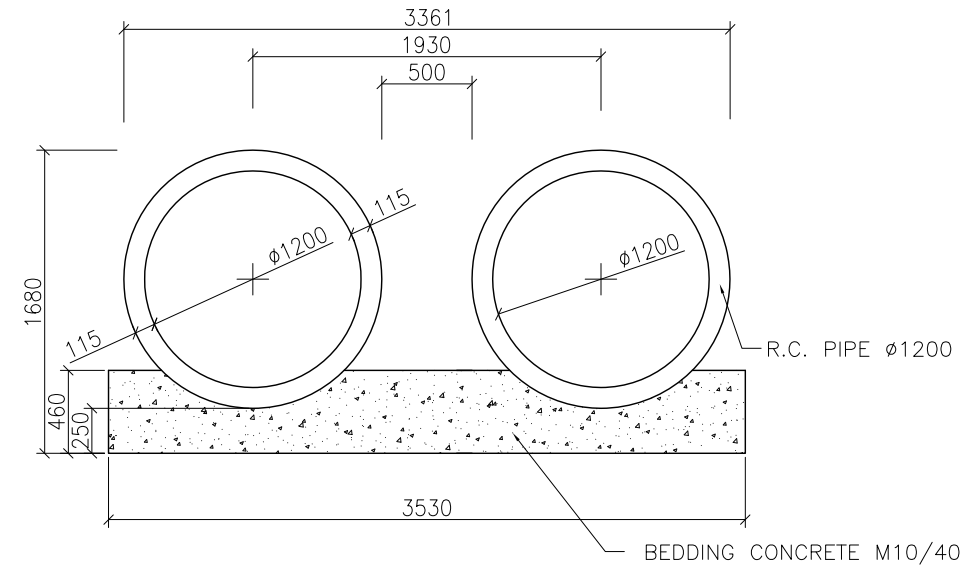

PIPE CULVERT (Ø1200 X 2)

SCALE B

WORK QUANTITIES (PER 10.0m)

ITEM	UNIT	QUANTITY	REMARKS
R.C. PIPE (Ø1200)	m	20.00	NP3
CONCRETE M10/40	m ³	13.62	
FORM WORK	m ²	9.20	
EXCAVATION	m ³	16.24	

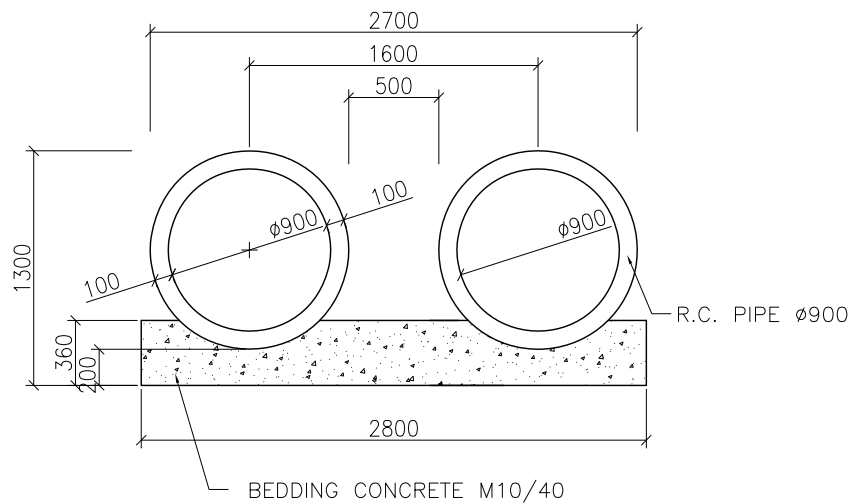

PIPE CULVERT (Ø900 X 2)

SCALE B

WORK QUANTITIES (PER 10.0m)

ITEM	UNIT	QUANTITY	REMARKS
R.C. PIPE (Ø900)	m	20.00	NP3
CONCRETE M10/40	m ³	8.36	
FORM WORK	m ²	7.20	
EXCAVATION	m ³	10.08	

NOTE:

1. All Dimension are in mm unless stated otherwise
2. In national highways concrete bedding is used and in other Roads gravel bedding may also be used

Government of Nepal Ministry of Physical Infrastructure & Transport Department of Roads			
STANDARD DRAWINGS FOR ROAD ELEMENTS			
PIPE CULVERTS FOR PLAIN AND HILLY AREA			
TYPICAL DRAWINGS			
	Recommended by	Approved by	SHEET. NO. 25
Signature			
	Arjun Jung Thapa	Devendra Karki	
Designation	Deputy Director General	Director General	

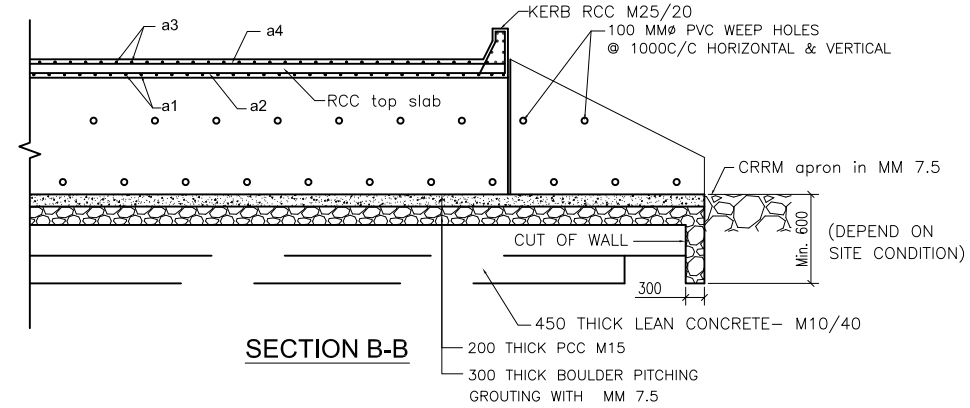
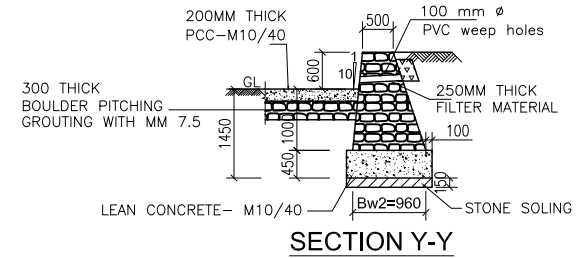
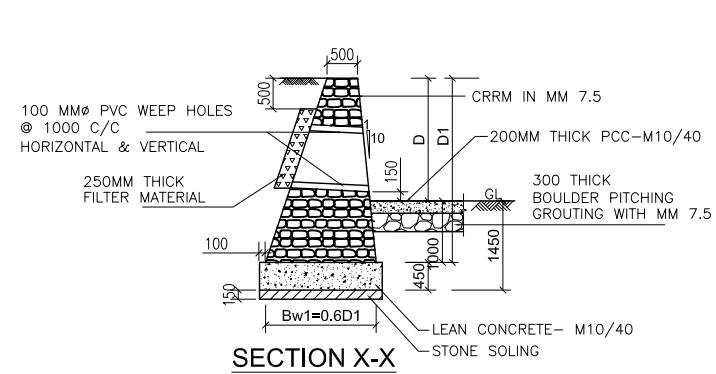
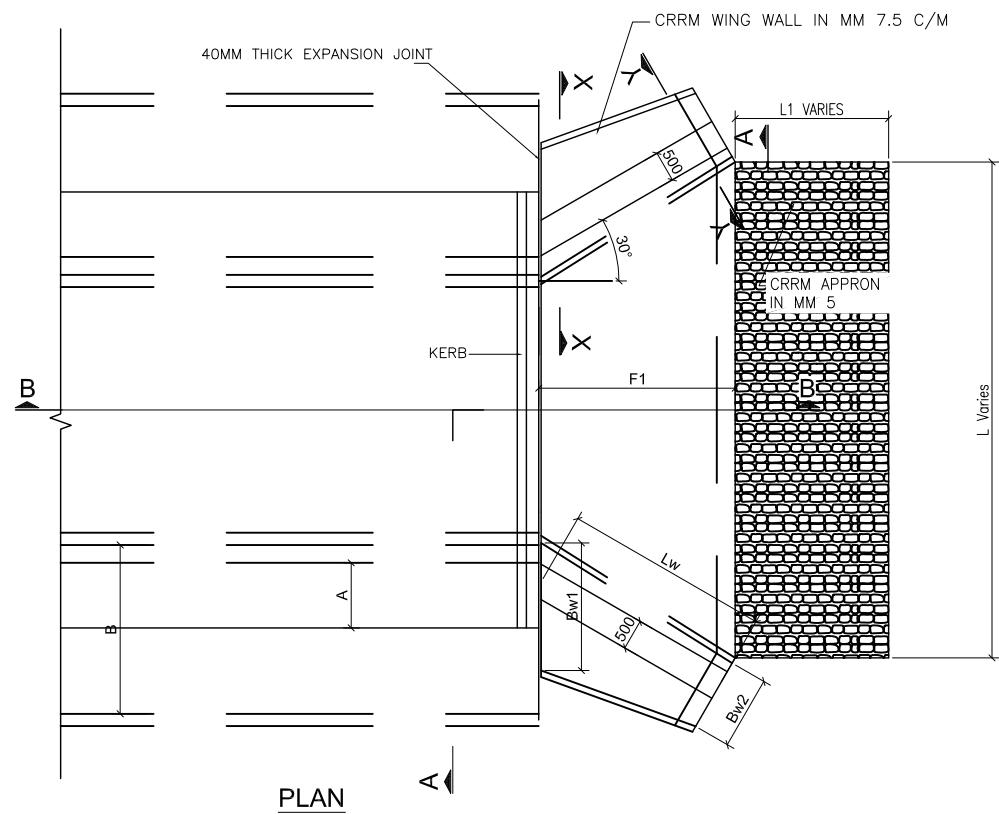

- NOTES:
1. CONCRETE mix should be M25/20 or as shown in the drawing.
 2. All edges are to be chamfered 100 mm x 100 mm.
 3. Mortar mix should be M5
 4. All Dimensions are in Millimetres except the dimensions in table.

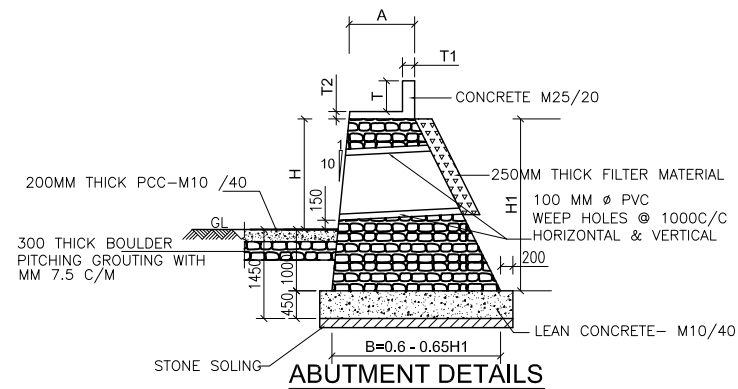
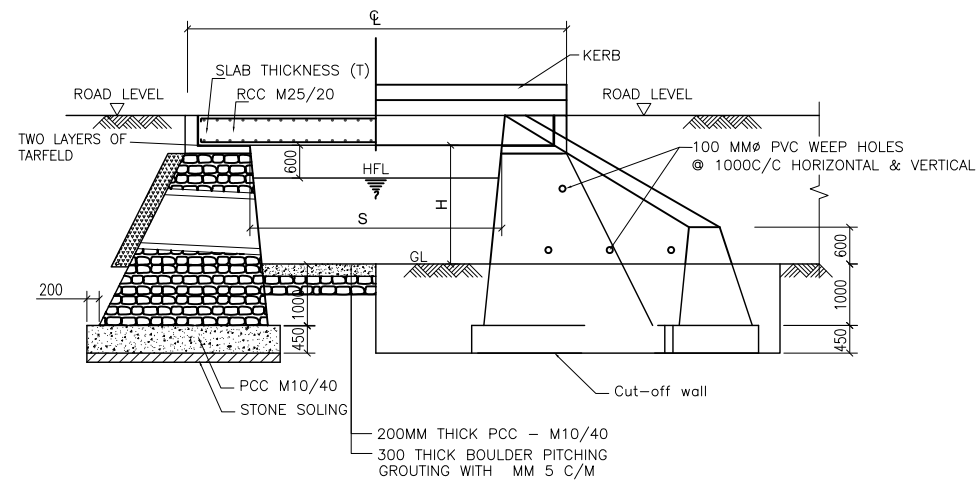

CULVERT TYPE	SIZE	DIMENSIONS (m)				QUANTITIES (AT ONE END)	
		Span, m	Bw1	Lw	F1	Bw2	MASONRY M ³
I	1.00	0.6D1	2 D1	0.86Lw	0.96	5.96	
II	2.00	0.6D1	2 D1	0.86Lw	0.96	5.96	
III	3.00	0.6D1	2 D1	0.86Lw	0.96	12.07	
IV	4.00	0.6D1	2 D1	0.86Lw	0.96	12.52	
V	5.00	0.6D1	2 D1	0.86Lw	0.96	12.95	
VI	6.00	0.6D1	2 D1	0.86Lw	0.96	13.21	

SCALE (m)



CULVERT TYPE	SIZE	DIMENSIONS(m)					QUANTITIES (LINEAR METRE EXCLUDING WING WALL APRON CUT-OFF WALL)			
		Span, m	T	T1	T2	A	L	CONCRETE M25 (M ³)	CONCRETE M15 (M ³)	Reinforcing Steel(kg) Kerb excluded
I	1.00	0.22	0.20	0.12	0.52	2.04	0.61	2.41	60.13	16.80
II	2.00	0.25	0.20	0.12	0.65	3.30	1.01	2.41	73.72	17.58
III	3.00	0.30	0.20	0.15	0.77	4.54	1.62	3.10	99.10	30.48
IV	4.00	0.38	0.20	0.15	0.77	5.54	2.49	3.10	179.99	30.48
V	5.00	0.42	0.20	0.20	0.77	7.00	3.87	3.10	211.12	30.48
VI	6.00	0.46	0.20	0.20	0.77	8.40	4.80	3.10	312.67	30.48

Government of Nepal
Ministry of Physical Infrastructure & Transport
Department of Roads

STANDARD DRAWINGS FOR ROAD ELEMENTS

SLAB CULVERT (NO FILL)

GENERAL DETAILS

Recommended by	Approved by	SHEET. NO. 26
Signature		
Designation		
Arjun Jung Thapa	Devendra Karki	
Deputy Director General	Director General	

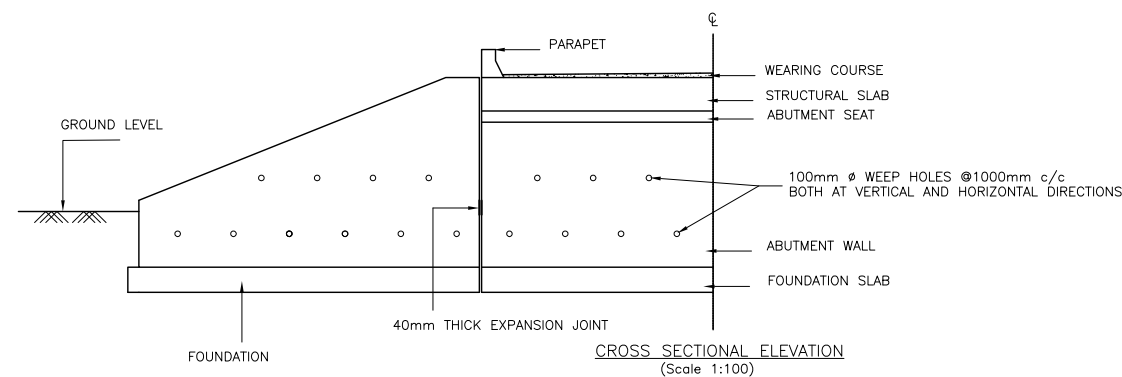
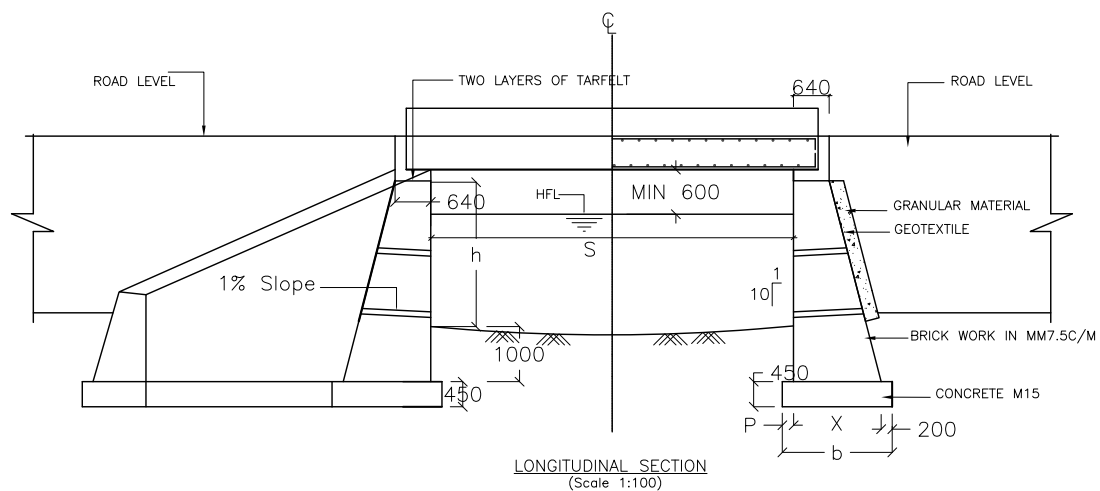
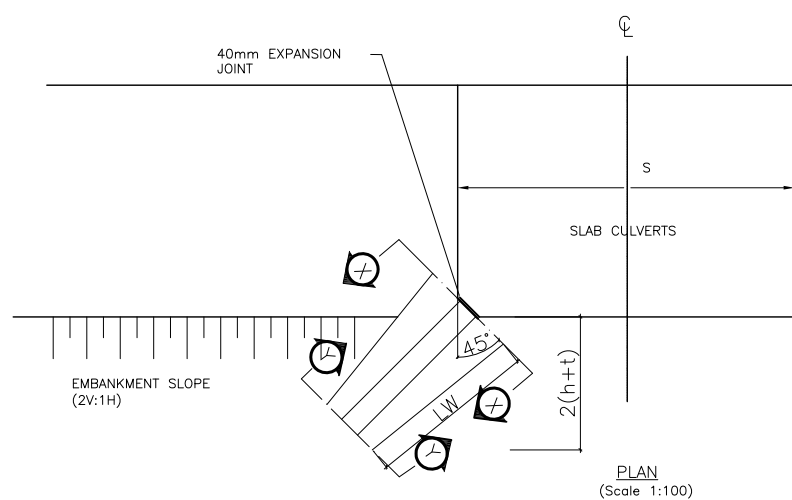

TABLE SHOWING ABUTMENT SECTIONS FOR DIFFERENT SPANS-HEIGHT

SPANS IN METERS S	h = 1100mm						h = 2600mm						h = 4100mm					
	b	X	P	R	TOE PRESSURE (KN/m ²)	REMARKS	b	X	P	R	TOE PRESSURE (KN/m ²)	REMARKS	b	X	P	R	TOE PRESSURE (KN/m ²)	REMARKS
3	1730	1330	200	4	113		1970	1570	200	6	172		2870	2370	300	4	190	
4	1730	1300	200	4	123		1970	1570	200	6	176		2870	2370	300	4	196	
5	1730	1300	200	4	141		1970	1570	200	6	190		2870	2370	300	4	207	
6	1730	1300	200	4	164		1970	1570	200	6	207		2870	2370	300	4	222	



WING WALL DETAILS

SPANS IN METERS S	h = 1100mm					h = 2600mm					h = 4100mm				
	Hw	Bw	Lw	R	P	Hw	Bw	Lw	R	P	Hw	Bw	Lw	R	P
3	2400	1090	3960	4	200	3900	1290	8210	6	200	5400	2140	12460	4	30
4	2475	1117	4180	4	200	3975	1310	8430	6	200	5475	2167	12680	4	30
5	2520	1132	4300	4	200	4020	1322	8550	6	200	5520	2132	12800	4	30
6	2560	1146	4420	4	200	4060	1333	8670	6	200	5560	2196	12920	4	30

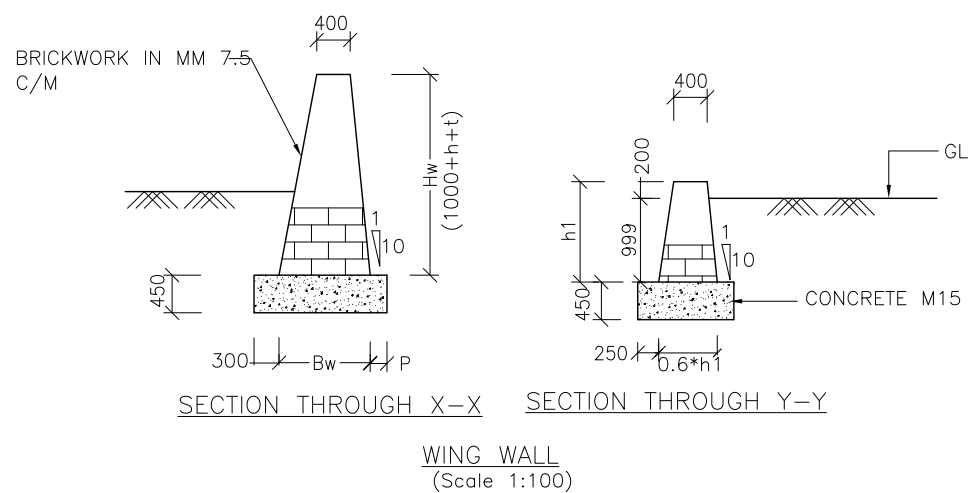
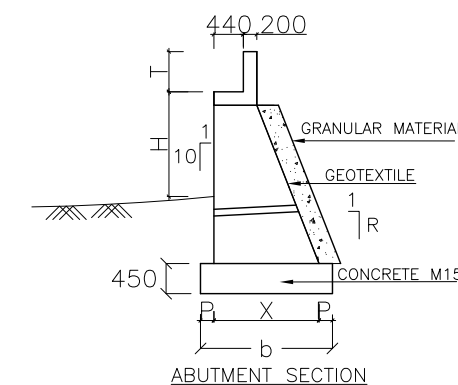

NOTES:

1. For PCC, concrete of grade M15/40 shall be used.
2. All exposed corners to have 25mm chamfer.
3. Back filling is to be done only after the top slab has been cast and all form and props removed.
4. Clear vertical joint 40mm thick is provided between wing wall and main wall.
5. This drawing should be read in conjunction with super structure details of slab culverts.

Government of Nepal
Ministry of Physical Infrastructure & Transport
Department of Roads

STANDARD DRAWINGS FOR ROAD ELEMENTS

SLAB CULVERT(NO FILL)

BRICK MASONRY ABUTMENTS

Recommended by	Approved by	SHEET. NO. 27
Signature	Signature	
Arjun Jung Thapa	Devendra Karki	
Designation	Designation	
Deputy Director General	Director General	

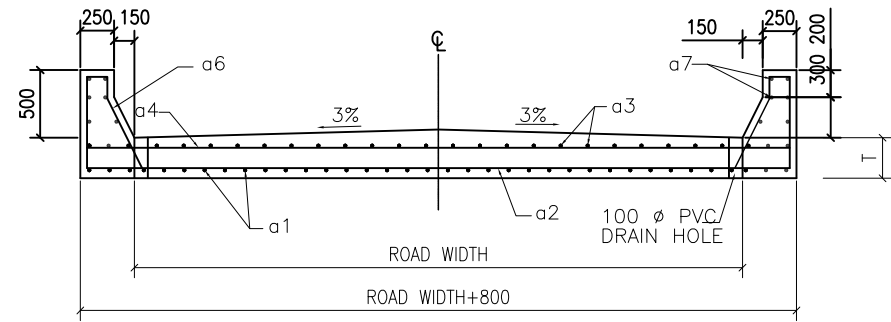

TRANSVERSE SECTION

BAR BENDING SCHEDULE PER ONE LINEAR METRE OF CULVERT (EXCLUDING CURB & ABUTMENT SEAT)

CULVERT TYPE	MARK a1				MARK a2				MARK a3				MARK a4				MARK a5			
	L				L				L				L				L			
	DIA (mm)	SPACING	NO. REQD./PER METRE	L	Remarks	DIA	SPACING	NO. REQD./PER METRE	L	DIA	SPACING	NO. REQD./PER METRE	L	DIA	SPACING	NO. REQD./PER METRE	L	DIA	NO. REQD./PER METRE	L
I	12	140	7.14	1.54	Every third bar to be bent up	10	150	6.67	5.10	10	300	3.33	1.54	10	300	3.33	5.10	12	2	5.10
II	12	120	8.33	2.80	Every third bar to be bent up	10	150	6.67	5.10	10	300	3.33	2.80	10	300	3.33	5.10	12	2	5.10
III	16	140	7.14	4.04	Every third bar to be bent up	10	150	6.67	5.10	10	300	3.33	4.04	10	300	3.33	5.10	12	2	5.10
IV	16	110	9.09	5.04	Every third bar to be bent up	10	150	6.67	5.10	10	200	5.00	6.04	10	200	2.00	5.10	12	2	5.10
V	20	140	7.14	6.04	Alternate bar to be bent up	12	170	5.88	5.10	12	300	3.33	6.50	12	300	3.33	5.10	12	2	5.10
VI	20	130	7.69	7.04	Alternate bar to be bent up	12	150	6.67	5.10	12	200	5.00	7.80	12	200	5.00	5.10	12	2	5.10

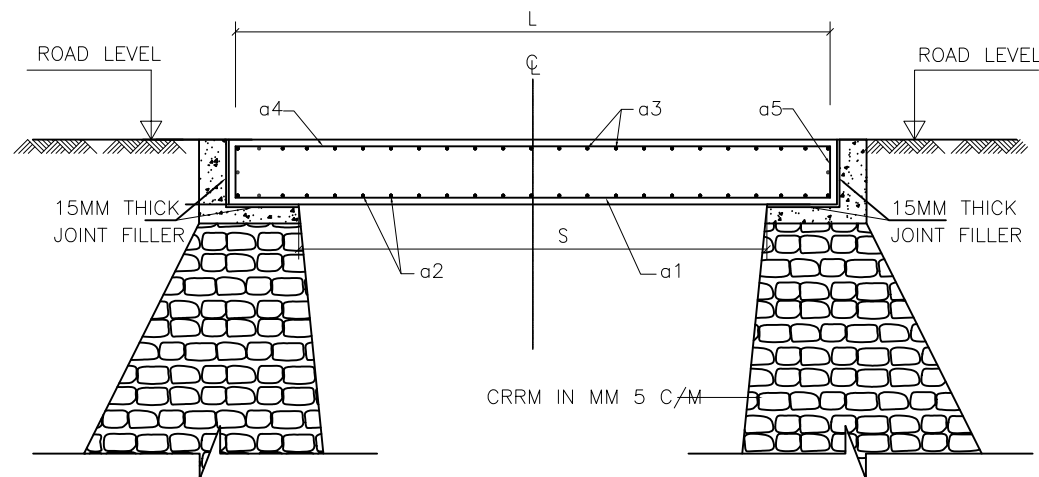

LONGITUDINAL SECTION

BAR BENDING SCHEDULE OF ABUTMENT SEAT PER LINEAR METRE

CULVERT TYPE	MARK s1				MARK s2				MARK s3			
	1000				120-170				600			
	DIA (mm)	NO.	LENGTH	TOTAL LENGTH	DIA (mm)	NO.	LENGTH	TOTAL LENGTH	DIA (mm)	NO.	LENGTH	TOTAL LENGTH
I	10	9	1.00	9.00	10	5	1.25	6.25	10	8	0.60	4.80
II	10	9	1.00	9.00	10	5	1.26	6.32	10	8	0.60	4.80
III	10	9	1.00	9.00	10	5	1.58	7.90	10	8	0.60	4.80
IV	10	9	1.00	9.00	10	5	1.94	9.69	10	8	0.60	4.80
V	10	9	1.00	9.00	10	5	2.23	11.15	10	8	0.60	4.80
V	10	9	1.00	9.00	10	5	2.27	11.35	10	8	0.60	4.80

BAR BENDING SCHEDULE OF CURB

CULVERT TYPE	MARK a6				MARK a7			
	520				L			
	DIA (mm)	NO.	LENGTH	TOTAL LENGTH	DIA (mm)	NO.	LENGTH	TOTAL LENGTH
I	10	22	1.74	38.17	10	12	1.96	23.52
II	10	36	1.74	62.46	10	12	3.22	38.64
III	10	48	1.74	83.28	10	12	4.46	53.52
IV	10	56	1.74	97.16	10	12	5.44	65.28
V	10	70	1.74	121.45	10	12	6.90	82.80
VI	10	80	1.74	139.20	10	12	7.70	92.40

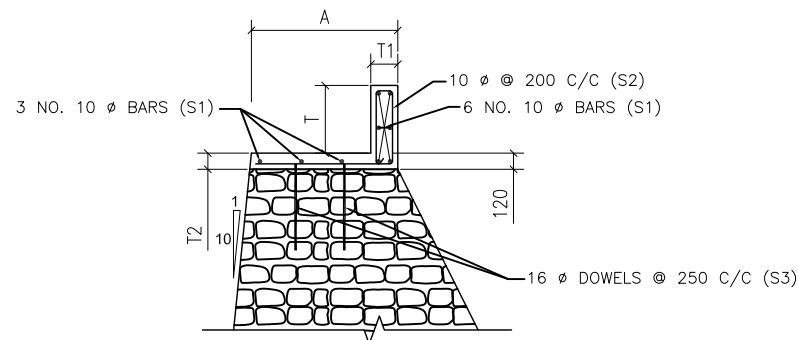

ABUTMENT SEAT DETAIL

NOTES:

1. TMT BARS having characteristic strength 500 N/mm should be used.
2. All the dimensions are in millimetres except the dimensions in table.

SCALE (m)

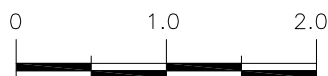

Government of Nepal Ministry of Physical Infrastructure & Transport Department of Roads			
STANDARD DRAWINGS FOR ROAD ELEMENTS			
SLAB CULVERT (NO FILL)			
REINFORCEMENT DETAILS			
Recommended by	Approved by		SHEET. NO. 28
Signature	Signature		
Designation	Designation		
Deputy Director General	Director General		

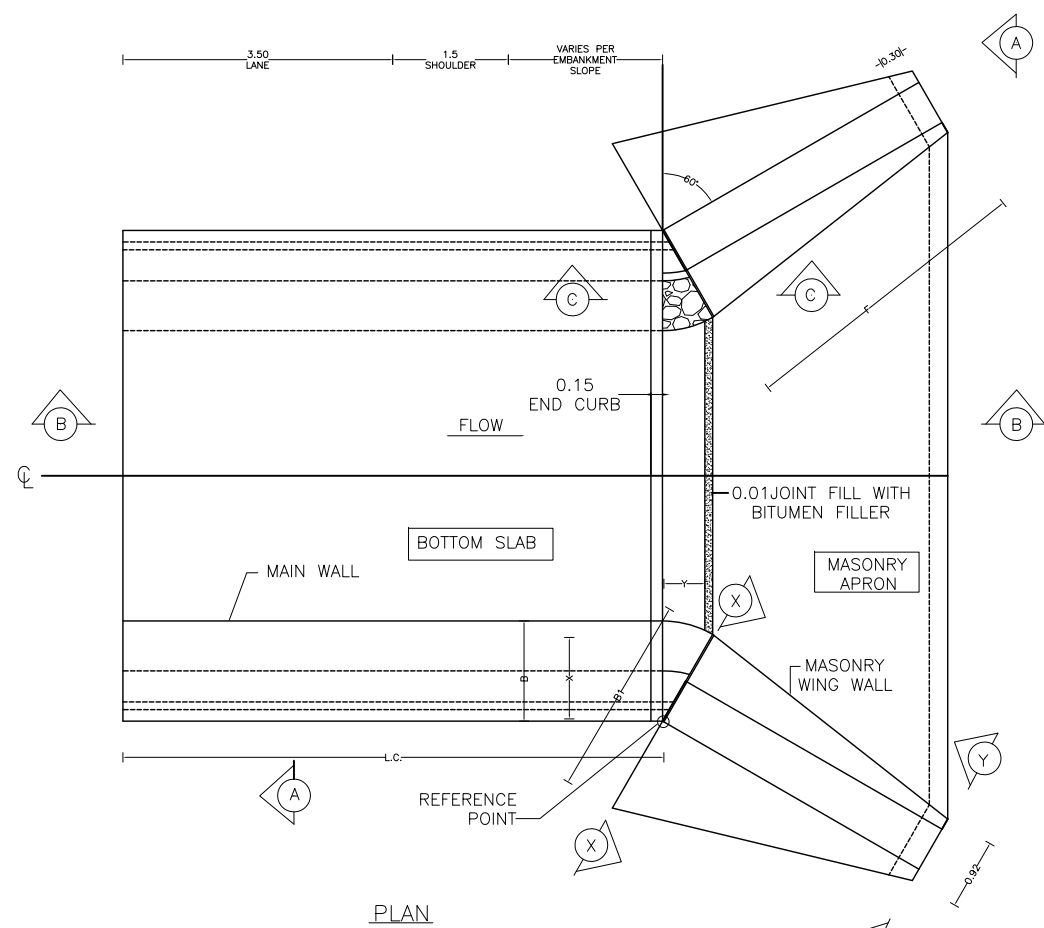

X=0.878
Y=0.58

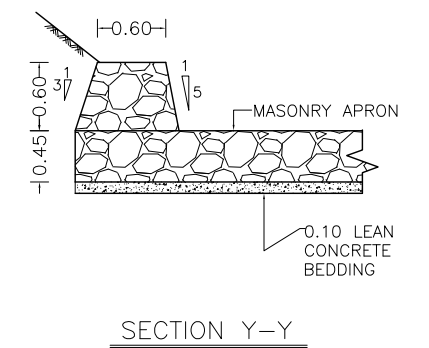
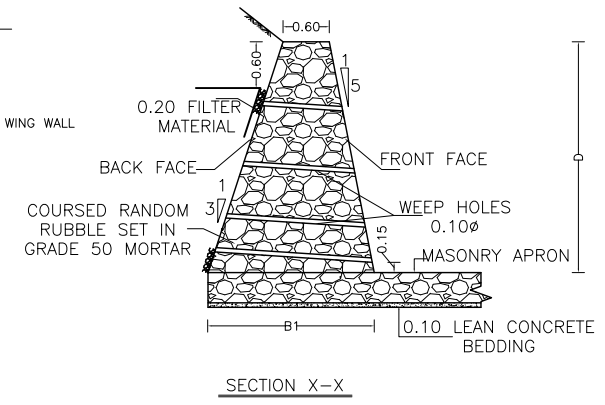
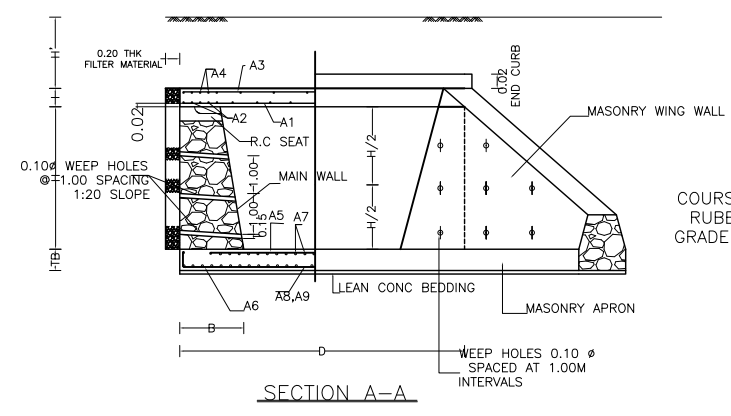

CULVERT TYPES	CULVERT SIZES		MAIN WALL QUANTITIES FOR ONE LIN. METER OF CULVERT INCLUDING R.C. EXCLUDING WING WALL, APRONS AND ENDCURB)														WING WALL QUANTITIES FOR WING WALL, APRON AND CUT OFF WALL AT ONE END																		
			DIMENSIONS				LEAN CONC.				CONCRETE				MASONRY		REINFORCING STEEL IN KG				FILTER MATERIAL		DIMENSIONS				MASONRY			LEAN CONC.			FILTER MATERIAL		
			S	H	H'	t	TB	A	B	D	M3	M3	M3	M3	M3	M3	M3	M3	M3	M3	M3	M3	M3	M3	M3	M3	M3	M3	M3	M3	M3	M3	M3	M3	M3
1	1.0	2.0	0-2.0	0.26	0.30	0.520	0.900	2.40	0.31	1.51	2.53	94.00	96.00	99.00	101.00	1.00	1.80	2.26	3.84	20.00	1.50	1.80	2.10	2.81	5.10	35.00	2.60	2.90	1.20	1.10	1.10				
2	1.5	2.5	0-2.0	0.31	0.30	0.645	1.125	3.25	0.40	2.18	4.04	172.00	177.00	184.00	191.00	1.20	2.10	2.81	5.10	35.00	2.60	2.90	1.20	1.10	1.10	1.10	1.10	1.10	1.10	1.10	1.10	1.10			
*2A	1.7	1.5	0-2.0	0.31	0.30	0.645	0.925	3.25	0.40	2.18	2.20	172.00	177.00	184.00	190.00	0.80	1.56	1.81	2.80	13.00	1.20	1.10	1.10	1.10	1.10	1.10	1.10	1.10	1.10	1.10	1.10	1.10	1.10		
3	2.0	2.0	0-2.0	0.35	0.30	0.520	0.900	3.40	0.41	2.37	2.53	210.00	217.00	224.00	234.00	1.00	1.85	2.35	4.05	24.00	2.00	1.90	2.11	2.85	5.23	38.00	2.90	3.00	1.20	1.10	1.10				
4	2.0	2.5	0-2.0	0.35	0.30	0.645	1.125	3.75	0.48	2.63	4.04	250.00	259.00	266.00	277.00	1.20	2.11	2.85	5.23	38.00	2.90	3.00	2.11	2.85	5.23	38.00	2.90	3.00	1.20	1.10	1.10				
5	2.5	2.5	0-2.0	0.42	0.45	0.645	1.125	4.25	0.50	3.90	4.04	255.00	265.00	272.00	280.00	1.20	2.15	2.92	5.36	41.00	3.30	3.20	2.15	2.92	5.36	41.00	3.30	3.20	1.20	1.10	1.10				
6	3.0	3.0	0-2.0	0.48	0.45	0.770	1.380	5.10	0.58	4.97	5.90	378.00	395.00	414.00	430.00	1.40	2.45	3.48	6.65	63.00	4.90	4.70	2.45	3.48	6.65	63.00	4.90	4.70	1.20	1.10	1.10				
7	4.0	3.0	0-2.0	0.56	0.45	0.770	1.380	6.10	0.68	6.40	5.90	574.00	595.00	615.00	640.00	1.50	2.49	3.56	6.84	69.00	5.70	4.90	2.49	3.56	6.84	69.00	5.70	4.90	1.20	1.10	1.10				

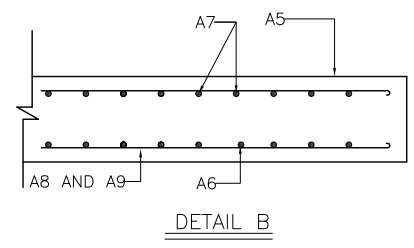
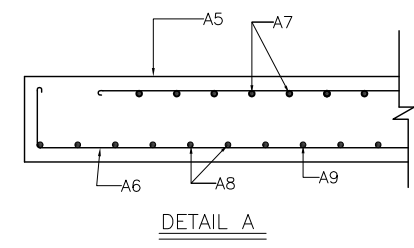
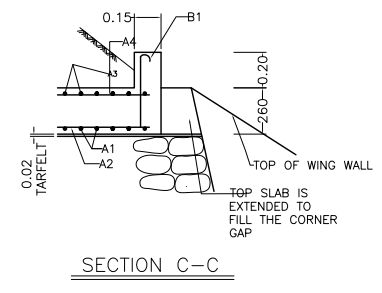
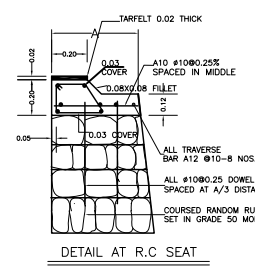
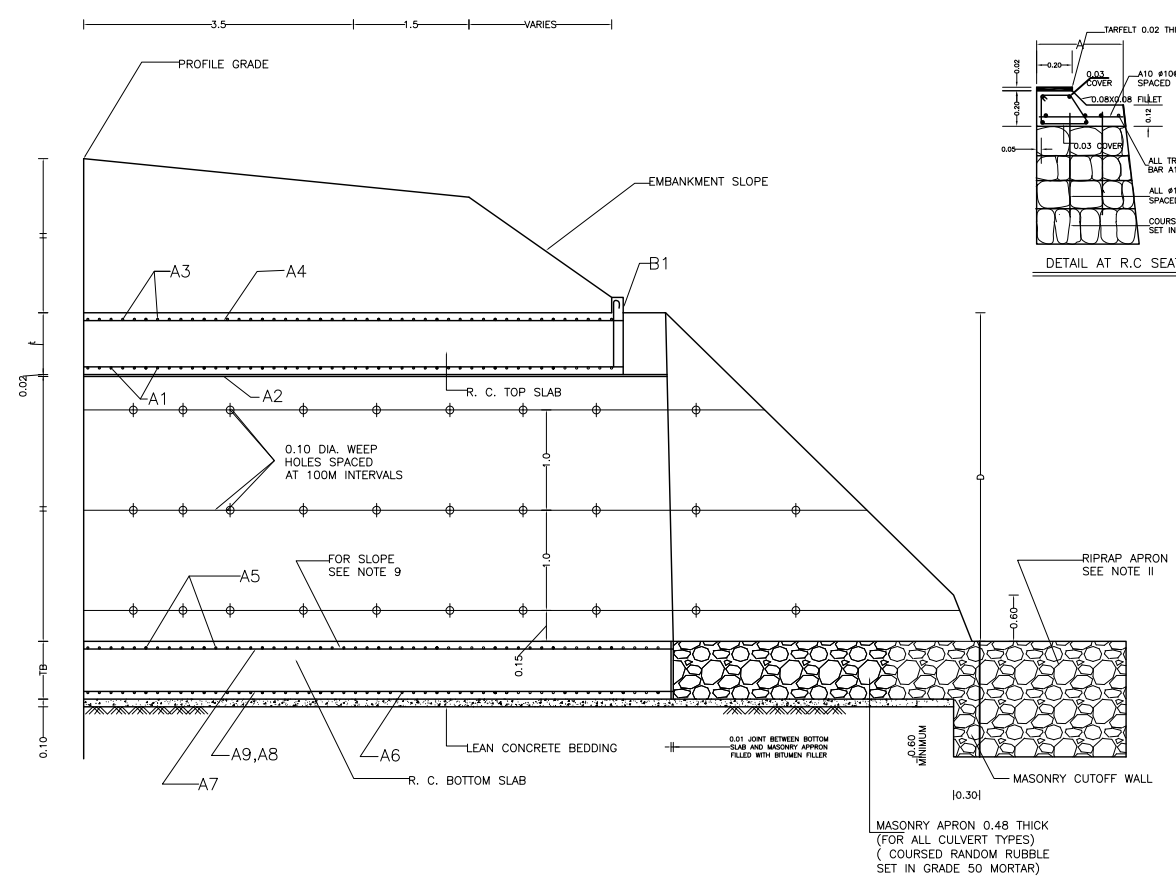

- NOTES:
- FOR GENERAL NOTES SEE DWG NO.001
 - FOR BAR BENDING SCHEDULE SEE DWG NO.013
 - CALCULATED DIMENSIONS AND APPROXIMATE QUANTITIES ARE FOR GUIDANCE ONLY
 - CONCRETE COVER SHALL BE 0.05 EXCEPT STATED OTHERWISE
 - ORD CONCRETE PRESCRIBED MIX 250/ 40 SHALL BE USED
 - ALL DIMENSION ARE IN METER UNLESS OTHERWISE STATED
 - ALL EXPOSED CORNER TO HAVE 25MM CHAMFER
 - BACK FILLING IS TO BE DONE ONLY AFTER THE TOP SLAB HAS BEEN CAST AND ALL FORM OF PROPS REMOVED
 - THE ENGINEER SHALL CHECK AND APPROVED BEFORE CONSTRUCTION BEGINS
 - CLEAR VERTICAL JOINT IS PROVIDED BETWEEN WING WALL AND MAIN WALL
 - RIPRAP APRONS AT OUTLET AND INLET SHALL BE PROVIDED AS PER DWG NO.
 - LENGTH OF CULVERT LC SHALL BE AS PER HIGHWAY DWGS OR AS DIRECTED BY ENGINEERS
 - CULVERT CONSTRUCTION SHALL BE CARRIED OUT IN ACCORDANCE WITH THE SPECIFICATIONS

Government of Nepal
Ministry of Physical Infrastructure & Transport
Department of Roads

STANDARD DRAWINGS FOR ROAD ELEMENTS

SLAB CULVERT (WITH FILL)

GENERAL DETAILS

Recommended by	Approved by	SHEET. NO. 29
Signature	Signature	
Designation	Designation	

Arjun Jung Thapa
Deputy Director General

Devendra Karli
Director General

DOUBLE CELL 'DETAILS'

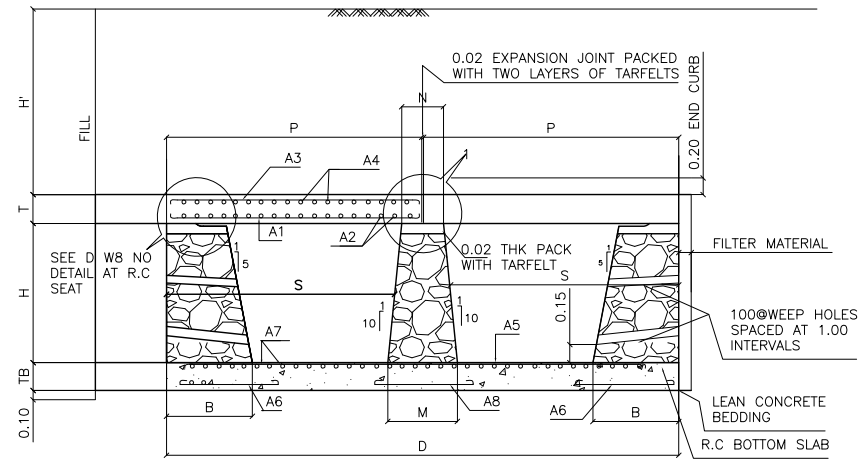

CROSS SECTION A-A

TB=BOTTOM SLAB THICKNESS

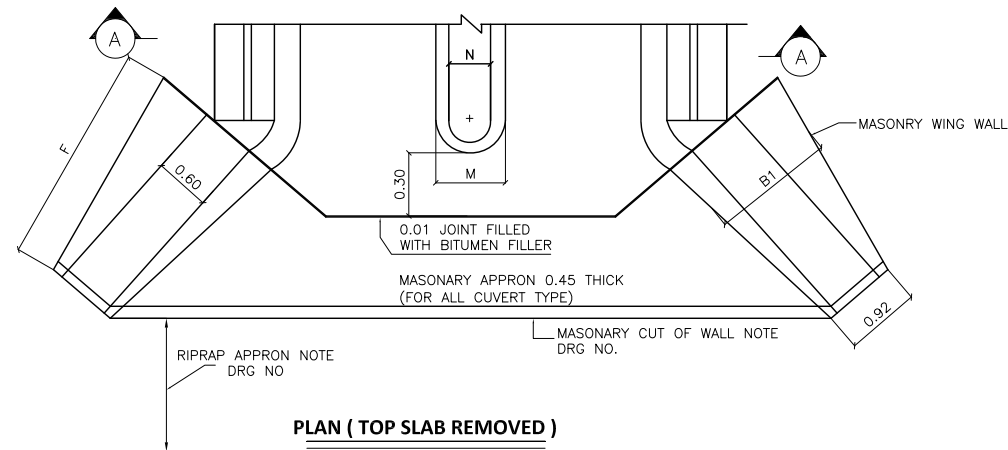

PLAN (TOP SLAB REMOVED)

TRIPLE CELL 'DETAILS'

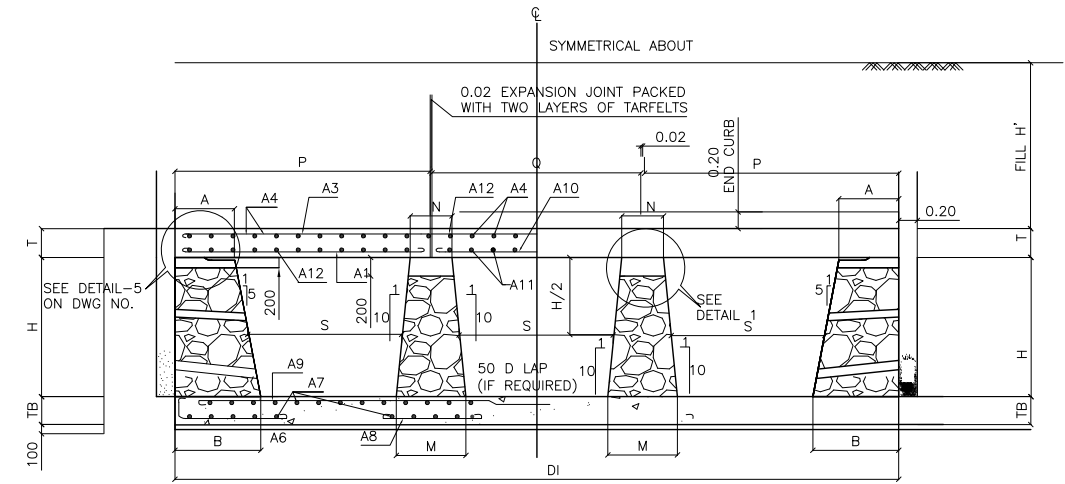

CROSS SECTION B-B

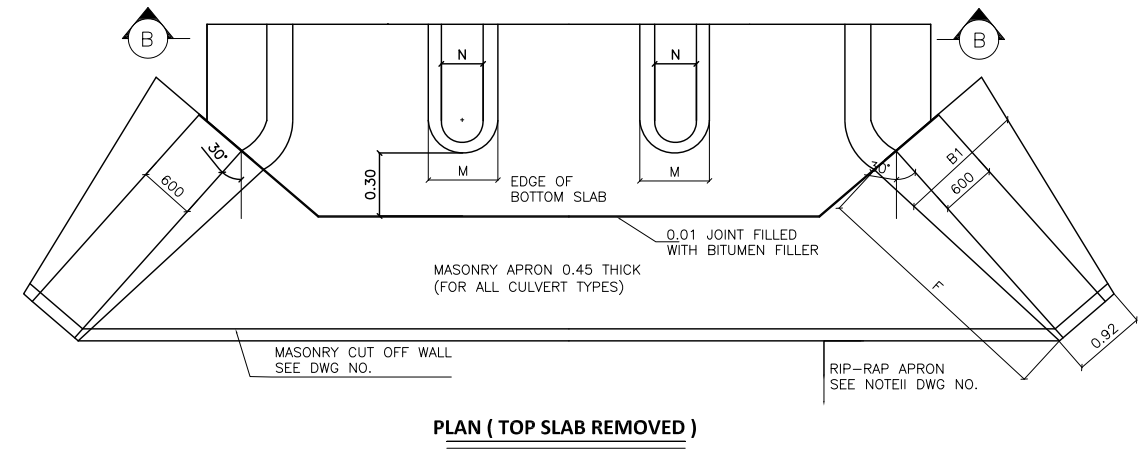

PLAN (TOP SLAB REMOVED)

CULVERT TYPE	DIMENSIONS (DOUBLE CELL)											APPROX QUANTITIES PER LIN METER OF CULVERT EXCLUDING WINGWALL, APRON & END CURB							
	CULVERT SIZE		H' (FILL)	T	TB	A	B	D	M	N	P	LEAN CONC 100/40	CONC 250/40	MASONRY	FILTER MATERIAL	REINFORCING STEEL IN KG.			
S	H	H' 0-0.6														H' 0.6-1.0	H' 1.0-1.5	H' 1.5-2.0	
1	1.70	1.50	0-2.0	0.31	0.30	0.645	0.925	5.55	0.75	0.45	2.76	0.63	3.68	3.00	0.80	340	348	360	372
2	2.00	2.00	0-2.0	0.35	0.30	0.520	0.900	6.20	1.00	0.60	3.09	0.69	4.32	4.00	1.00	428	443	457	473
3	2.00	2.50	0-2.0	0.33	0.30	0.645	1.125	6.75	1.25	0.75	3.36	0.75	4.74	6.40	1.20	497	512	526	545
4	2.50	2.50	0-2.0	0.42	0.45	0.645	1.125	7.75	1.25	0.75	3.86	0.85	7.10	6.40	1.20	365	584	597	612
5	3.00	3.00	0-2.0	0.48	0.45	0.770	1.350	9.30	1.50	0.90	4.64	1.00	8.78	9.32	1.40	837	870	904	934
6	4.00	3.00	0-2.0	0.56	0.45	0.770	1.350	11.30	1.50	0.90	5.64	1.20	11.82	9.32	1.50	1230	1270	1308	1354

CULVERT TYPE	DIMENSIONS (TRIPLE CELL)					APPROX QUANTITIES PER LIN METER OF CULVERT EXCLUDING WINGWALL, APRON & END CURB							
	CULVERT SIZE		H'	D1	Q	LEAN CONC 100/40	CONC 250/40	MASONRY	FILTER MATERIAL	REINFORCING STEEL IN KG.			
S	H	H' 0-0.6								H' 0.6-1.0	H' 1.0-1.5	H' 1.5-2.0	
1	1.70	1.50	0-2.0	7.85	2.28	0.86	5.20	3.82	0.80	498	509	527	544
2	2.50	2.50	0-2.0	11.25	3.48	1.20	10.28	8.74	1.20	817	845	863	892
3	3.00	3.00	0-2.0	13.50	4.18	1.42	13.14	12.74	1.40	1198	1246	1296	1339
4	4.00	3.00	0-2.0	16.50	5.18	1.72	17.25	12.74	1.50	1720	1780	1833	1902

CULVERT TYPE	APPROX QUANTITIES FOR WING WALL, APRON AND CUT OFF WALL AT ONE END OF CULVERT		
	MASONRY	LEAN CONC. BEDDING	FILTER MATERIAL
1	16.0	1.70	1.10
2	29.0	2.90	1.90
3	44.0	4.30	3.00
4	49.0	4.80	3.20
5	74.0	7.30	4.70
6	84.0	8.80	4.90

CULVERT TYPE	APPROX QUANTITIES FOR WING WALL, APRON AND CUT OFF WALL AT ONE END OF CULVERT		
	MASONRY	LEAN CONC. BEDDING	FILTER MATERIAL
1	19.0	2.30	1.10
2	56.0	6.50	3.20
3	86.0	9.70	4.70
4	98.0	11.80	4.90

NOTES:
1.CULVERT CONSTRUCTION SHALL BE CARRIED OUT IN ACCORDANCE WITH THE SPECIFICATION & SPECIAL PROVISIONS

Government of Nepal
Ministry of Physical Infrastructure & Transport
Department of Roads

STANDARD DRAWINGS FOR ROAD ELEMENTS

SLAB CULVERT DOUBLE AND TRIPLE CELL

GENERAL DETAILS

Recommended by	Approved by	SHEET. NO. 31
Signature		
Designation		
Deputy Director General	Director General	

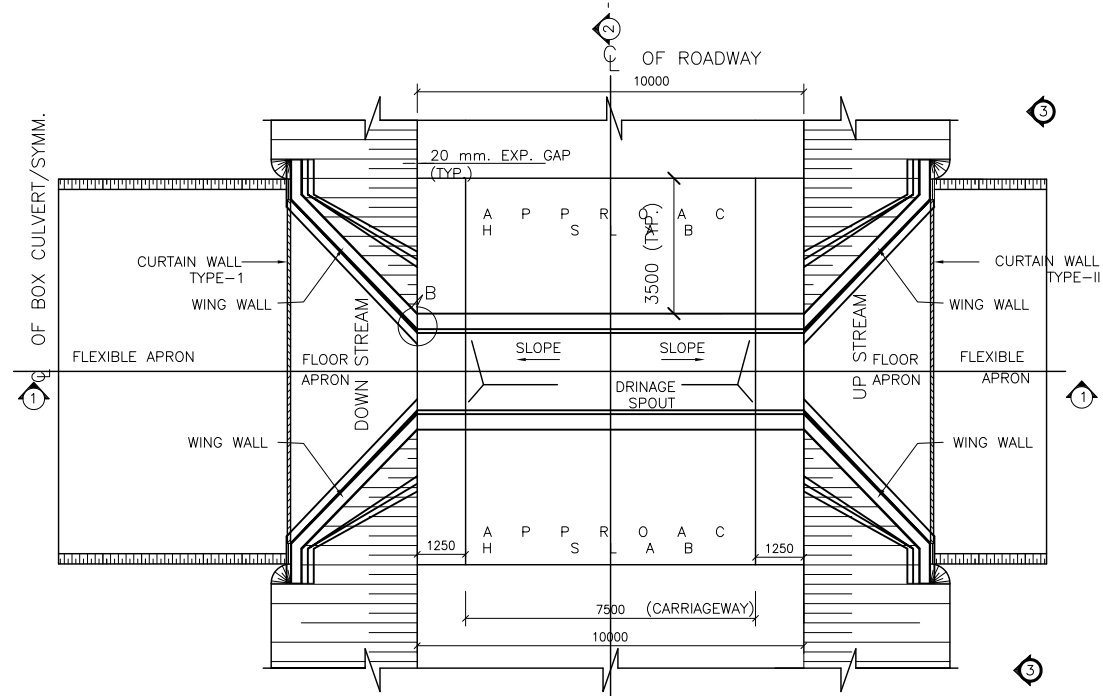

PLAN AT ROAD LEVEL

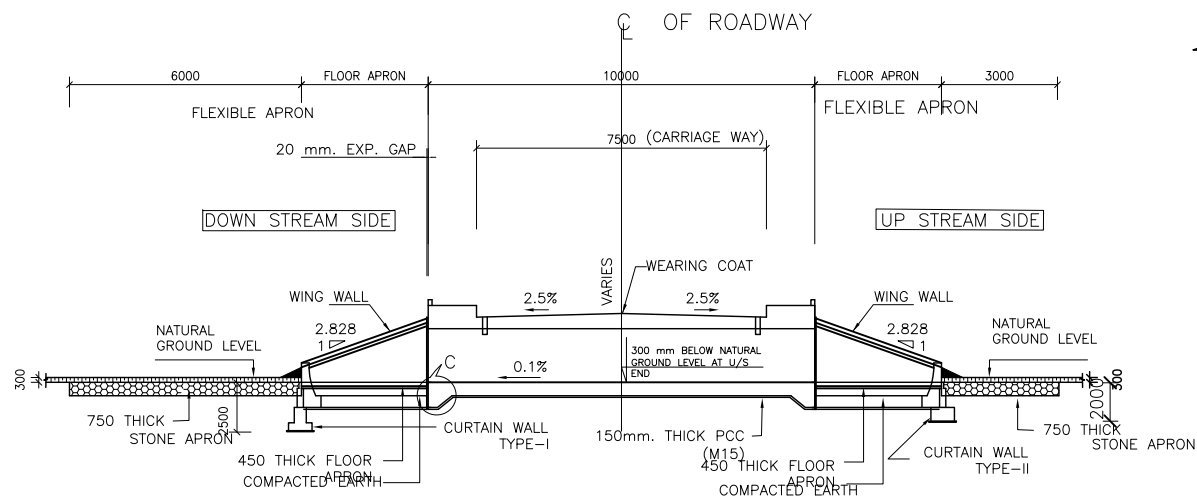

SECTION 1-1

TABLE SHOWING SALIENT DIMENSIONS OF SINGLE CELL BOX CULVERT

Box Cell Designation	a (mm)	b (mm)	c (mm)	d (mm)	e (mm)	f (mm)	g (mm)	h (mm)	Design base Pressure t/m ²
2 m x 2 m	2000	2000	500	350	380	300	NA	NA	11.6
3 m x 3 m	3000	3000	900	430	420	420	NA	NA	11.6
4 m x 3 m	4000	3000	400	450	500	500	NA	NA	11.6

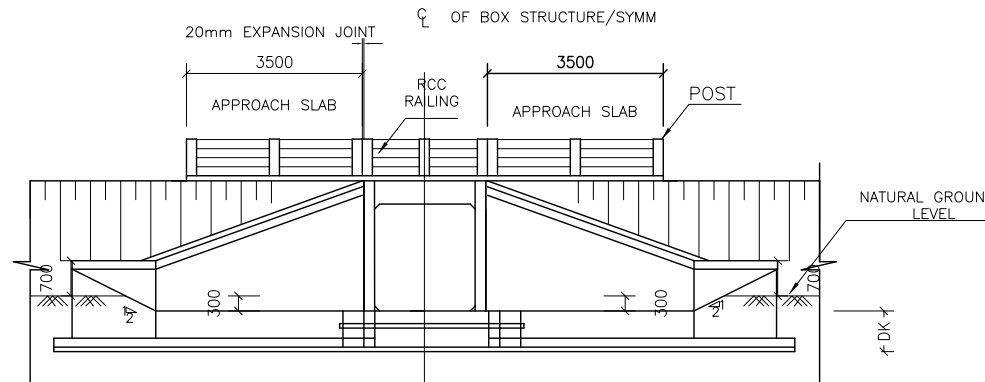

VIEW 3-3

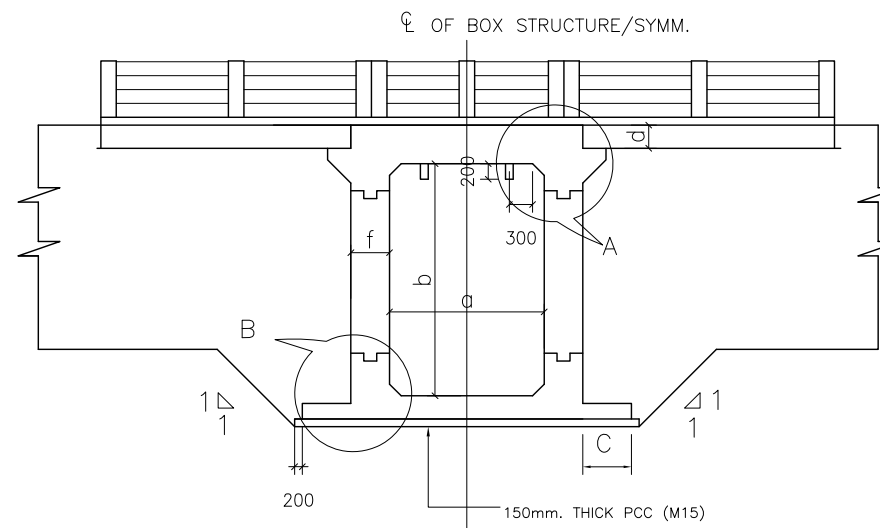
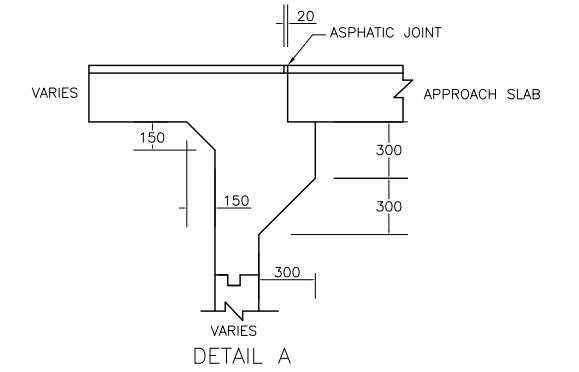

SECTION 2-2

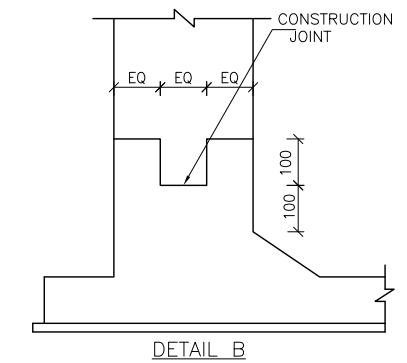

DETAIL B

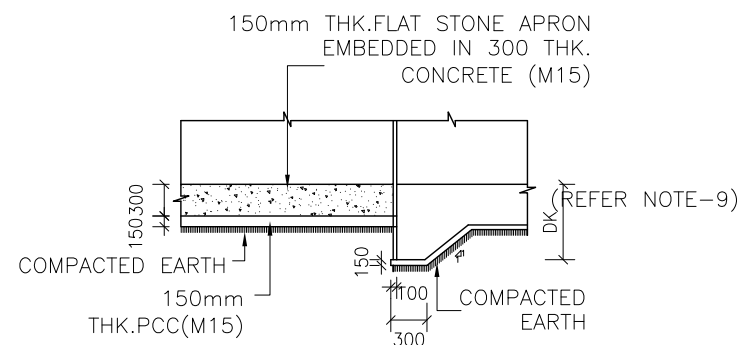

DETAIL -C

Government of Nepal Ministry of Physical Infrastructure & Transport Department of Roads			
STANDARD DRAWINGS FOR ROAD ELEMENTS			
BOX CULVERT SINGLE CELL WITHOUT EARTH CUSHION			
GENERAL DETAILS			
Recommended by	Approved by		SHEET. NO. 33
Signature	Signature		
Designation	Designation		
Deputy Director General	Director General		

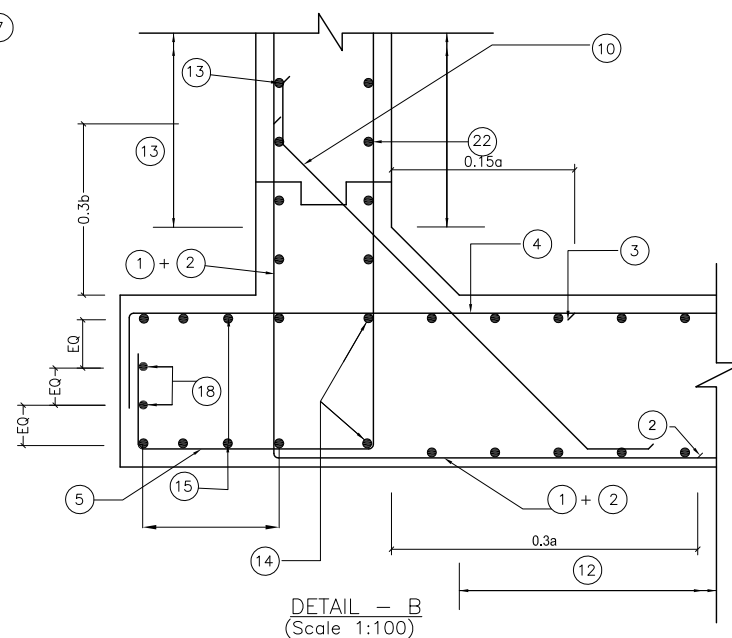
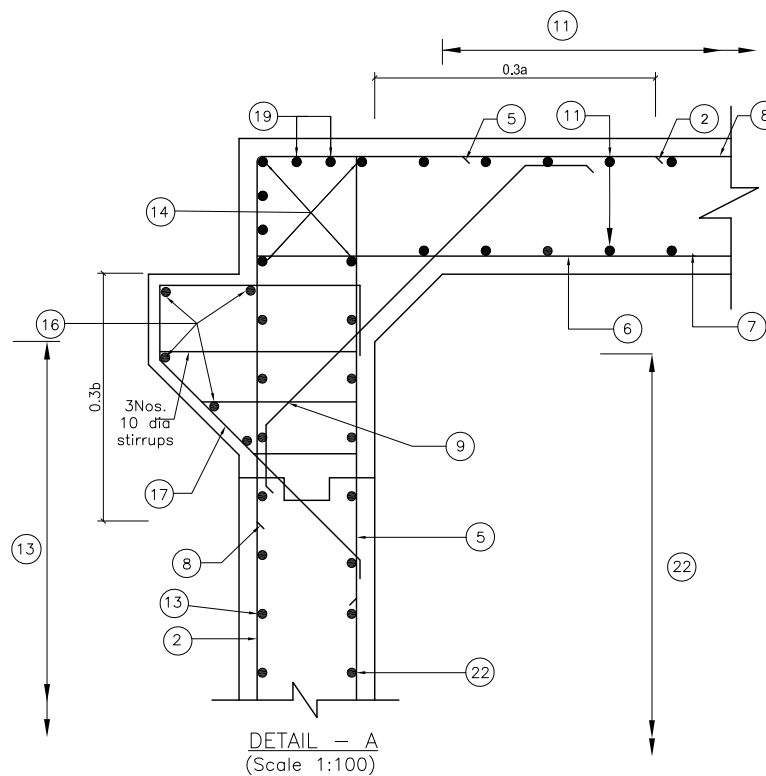
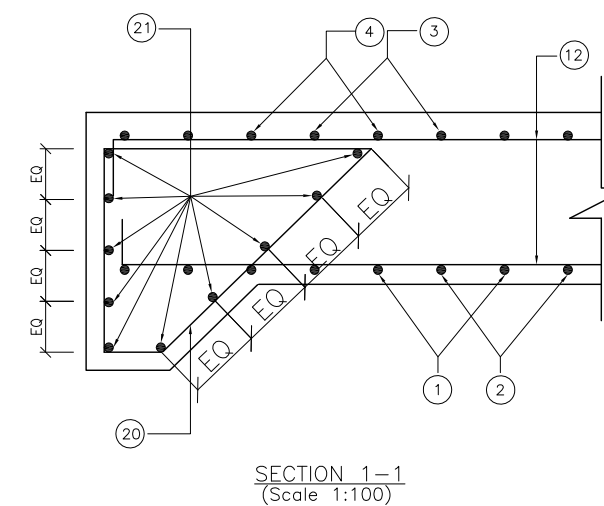
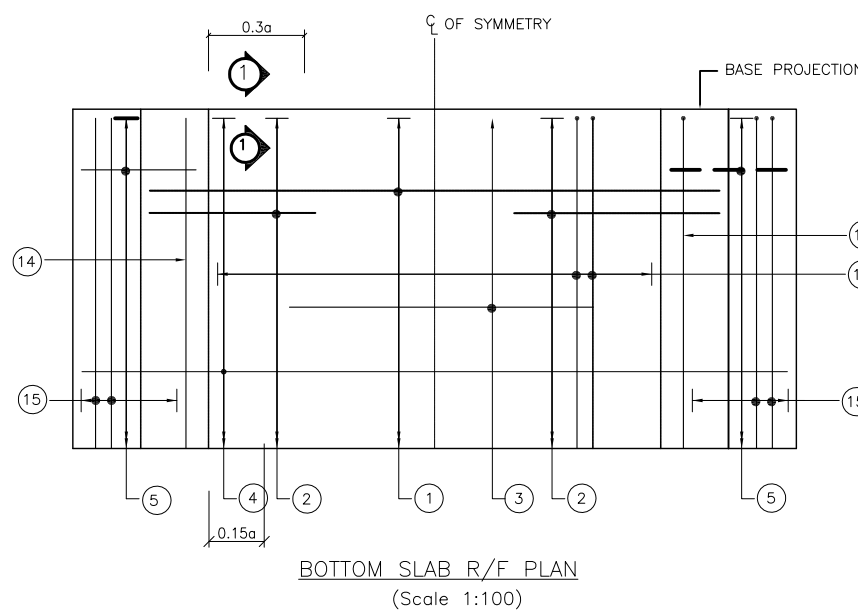
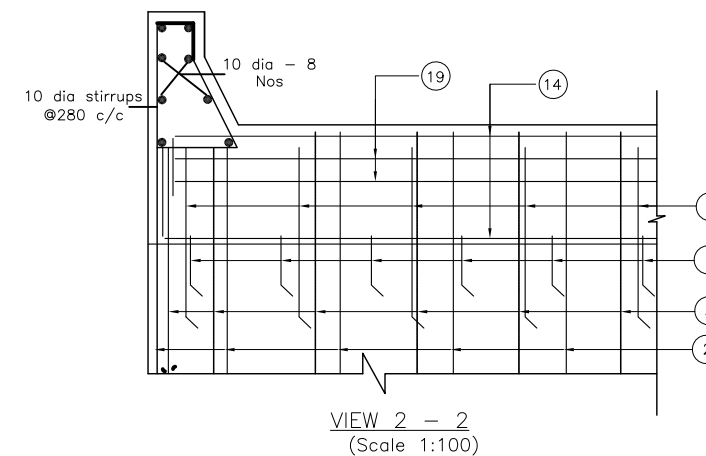
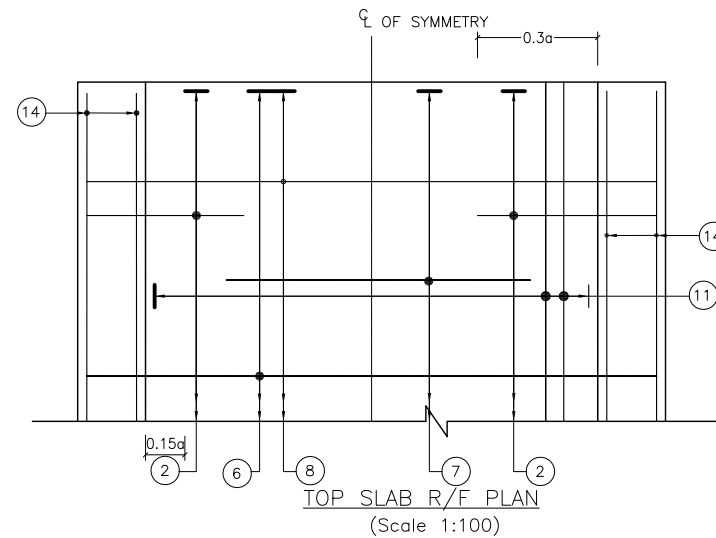
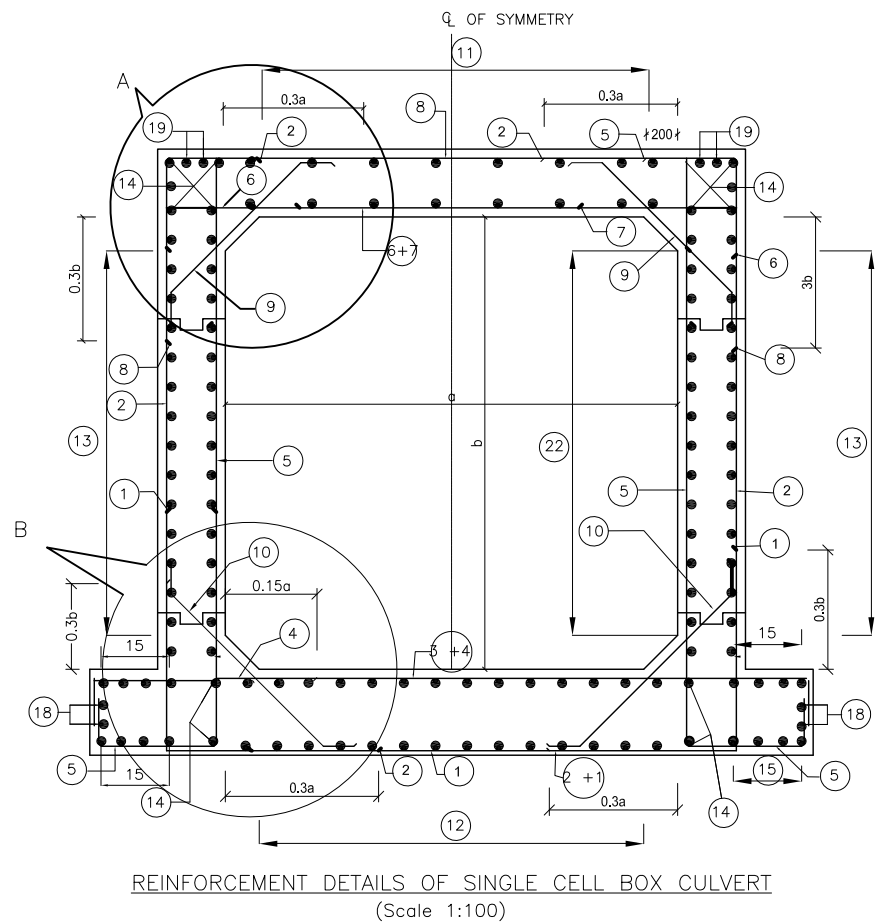

NOTES:

1. For General notes refer Drg. No. 01
2. For General arrangement refer Drg.No. 02
3. For Bar bending schedule refer Drg.No. 04
4. Bar required for kerbs and railings are not included in the bar bending schedule.

LEGEND:

- : TOP FACE BARS / OUTER FACE BARS
 - - - - : BOTTOM FACE BARS / INNER FACE BARS

Government of Nepal Ministry of Physical Infrastructure & Transport Department of Roads			
STANDARD DRAWINGS FOR ROAD ELEMENTS			
SINGLE CELL BOX CULVERT WITHOUT EARTH CUSHION			
REINFORCEMENT DETAILS			
Recommended by	Approved by		SHEET NO. 34
Signature	Signature		
Designation	Designation		
Arjun Jung Thapa	Devendra Karki		
Deputy Director General	Director General		

BAR MARK	BOX-CELL DESIGNATION No/ab/Ec	Single Cell Box Culvert 2m x2m without earth cushion										Single Cell Box Culvert 3m x3m without earth cushion										Single Cell Box Culvert 4m x3m without earth cushion									
		BAR DIA. in mm.	SPACING in mm.	M1 in mm.	M2 in mm.	LENGTH in mm.	NO. OF BARS	TOTAL LENGTH in mm.	Wt./m, kg	Weight, kg	BAR DIA. in mm.	SPACING in mm.	M1 in mm.	M2 in mm.	LENGTH in mm.	NO. OF BARS	TOTAL LENGTH in mm.	Wt./m, kg	Weight, kg	BAR DIA. in mm.	SPACING in mm.	M1 in mm.	M2 in mm.	LENGTH in mm.	NO. OF BARS	TOTAL LENGTH in mm.	Wt./m, kg	Weight, kg			
1		10	250	930	2500	4360	40	174400	0.62	108.1	10	200	1270	3740	6280	50	314000	0.62	194.7	10	200	1300	4900	7500	50	375000	0.62	232.5			
2		16	250	850	2630	4330	82	355060	1.58	561.0	16	200	1270	3740	6280	102	640560	1.58	1012.1	20	200	1600	3800	7000	102	714000	2.47	1763.6			
3		Bar not needed										12	200	2100	0	2100	50	105000	0.89	93.5	12	200	2800	0	2800	50	140000	0.89	124.6		
4		16	250	280	3500	4060	40	162400	1.58	256.6	16	200	320	5540	6180	50	309000	1.58	488.2	16	200	400	5700	6500	50	325000	1.58	513.5			
5		16	250	2630	700	3730	80	298400	1.58	471.5	12	150	3740	1220	5360	100	536000	0.89	477.0	12	175	3800	800	5000	116	580000	0.89	516.2			
6		16	250	250	2500	3000	40	120000	1.58	189.6	16	200	260	3740	4260	50	213000	1.58	336.5	16	200	260	4900	5420	50	271000	1.58	428.2			
7		Bar not needed										Bar not needed										8	200	2800	0	2800	50	140000	0.4	56.0	
8		10	250	900	2500	4300	40	172000	0.62	106.6	10	200	1270	3740	6280	50	314000	0.62	194.7	10	200	1300	4900	7500	50	375000	0.62	232.5			
9		10	250	200	900	1300	80	104000	0.62	64.5	10	200	200	1160	1560	100	156000	0.62	96.7	10	200	200	1300	1700	100	170000	0.62	105.4			
10		12	250	200	940	1340	80	107200	0.89	95.4	10	200	200	1160	1560	100	156000	0.62	96.7	10	200	200	1300	1700	100	170000	0.62	105.4			
11		10	250	200	9900	10300	16	164800	0.62	102.2	10	200	200	9900	10300	28	288400	0.62	178.8	10	200	275	9900	10450	38	397100	0.62	246.2			
12		10	250	200	9900	10300	16	164800	0.62	102.2	12	200	200	9900	10300	28	288400	0.89	256.7	12	200	250	9900	10400	38	395200	0.89	351.7			
13		10	250	200	9900	10300	16	164800	0.62	102.2	10	200	200	9900	10300	28	288400	0.62	178.8	12	200	250	9900	10400	28	291200	0.89	259.2			
14		10	-	160	9900	10220	12	122640	0.62	76.0	10	-	160	9900	10220	12	122640	0.62	76.0	10	-	160	9900	10220	12	122640	0.62	76.0			
15		10	250	200	9900	10300	12	123600	0.62	76.6	10	200	200	9900	10300	24	247200	0.62	153.3	10	200	250	9900	10400	12	124800	0.62	77.4			
16		12	-	0	9900	9900	10	99000	0.89	88.1	12	-	0	9900	9900	10	99000	0.89	88.1	12	-	0	9900	9900	10	99000	0.89	88.1			
17		12	250	1000	1250	2250	80	180000	0.89	160.2	12	200	1000	1260	2260	100	226000	0.89	201.1	12	200	1000	1300	2300	100	230000	0.89	204.7			
18		10	-	160	9900	10220	4	40880	0.62	25.3	10	-	160	9900	10220	4	40880	0.62	25.3	10	-	180	9900	10260	4	41040	0.62	25.4			
19		10	-	1600	9900	13100	8	104800	0.62	65.0	10	-	160	9900	10220	8	81760	0.62	50.7	10	-	160	9900	10220	8	81760	0.62	50.7			
20		10	150	1100	1550	4150	36	149400	0.62	92.6	10	200	1100	1550	4150	56	232400	0.62	144.1	10	150	1100	1550	4150	80	332000	0.62	205.8			
21		10	-	160	3500	3820	20	76400	0.62	47.4	10	-	160	5540	5860	20	117200	0.62	72.7	10	-	160	5700	6020	20	120400	0.62	74.6			
22		10	250	160	9900	10220	14	143080	0.62	88.7	10	200	210	9900	10320	28	288960	0.62	179.2	10	250	250	9900	10400	28	291200	0.62	180.5			
Total									2879.8										4594.9										5918.3		

NOTES:

1. Joint or lapping of bars shall be suitably Staggered as per clause 304.6 of IRC: 21-2000.
2. This Drawing shall be read in conjunction with other relevant Drawings.
3. Quantity of steel includes 5% extra for wastage and laps.
4. Quantity of steel are for per metre width.

Government of Nepal Ministry of Physical Infrastructure & Transport Department of Roads			
STANDARD DRAWINGS FOR ROAD ELEMENTS			
SINGLE CELL BOX CULVERT WITH NO EARTH CUSHION			
BAR BENDING SCHEDULE			
	Recommended by	Approved by	SHEET. NO. 35
Signature			
	Arjun Jung Thapa	Devendra Karki	
Designation	Deputy Director General	Director General	

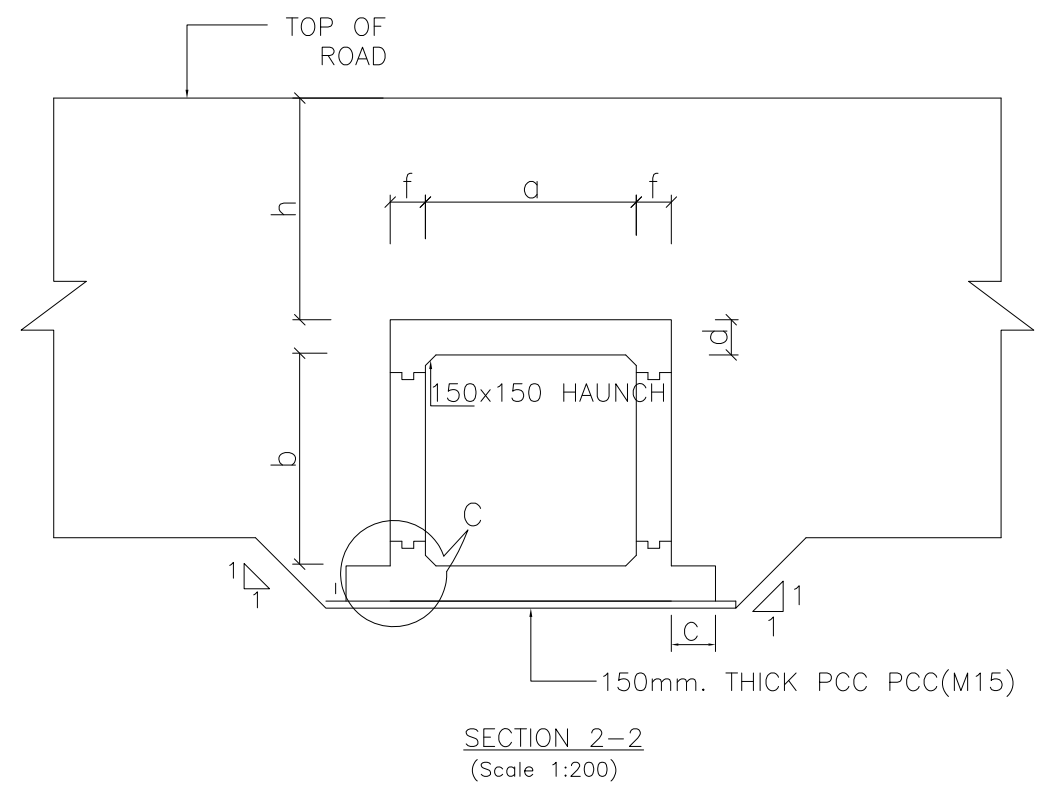
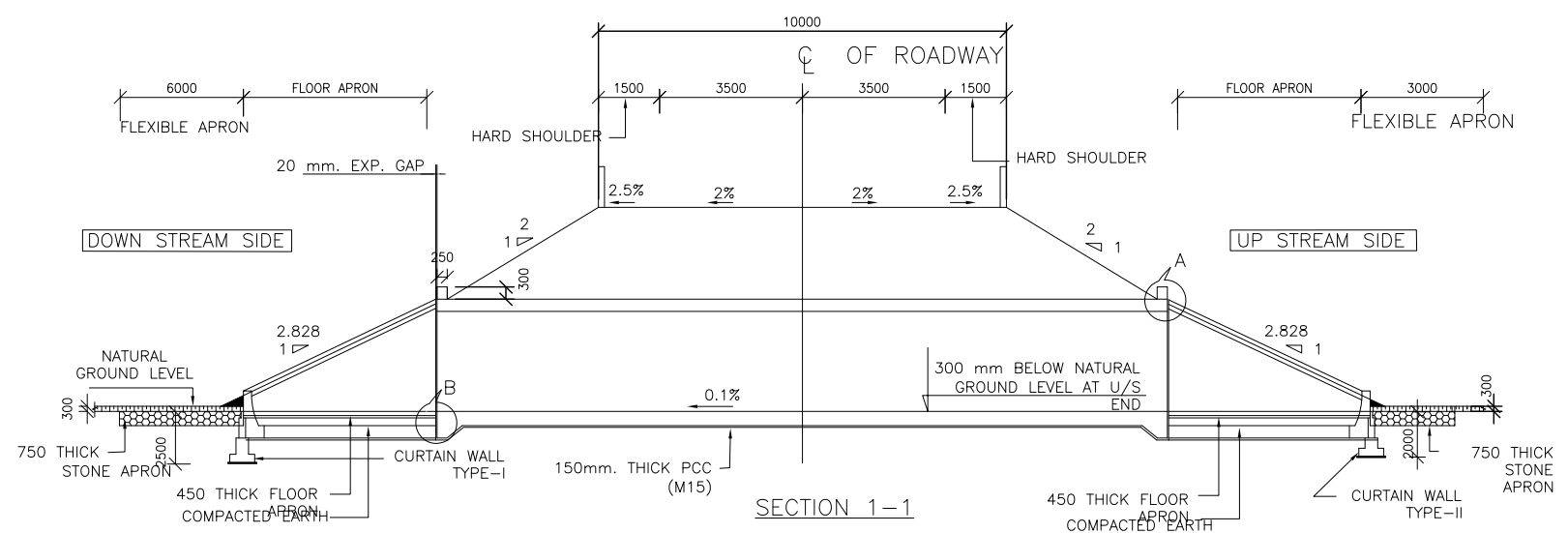
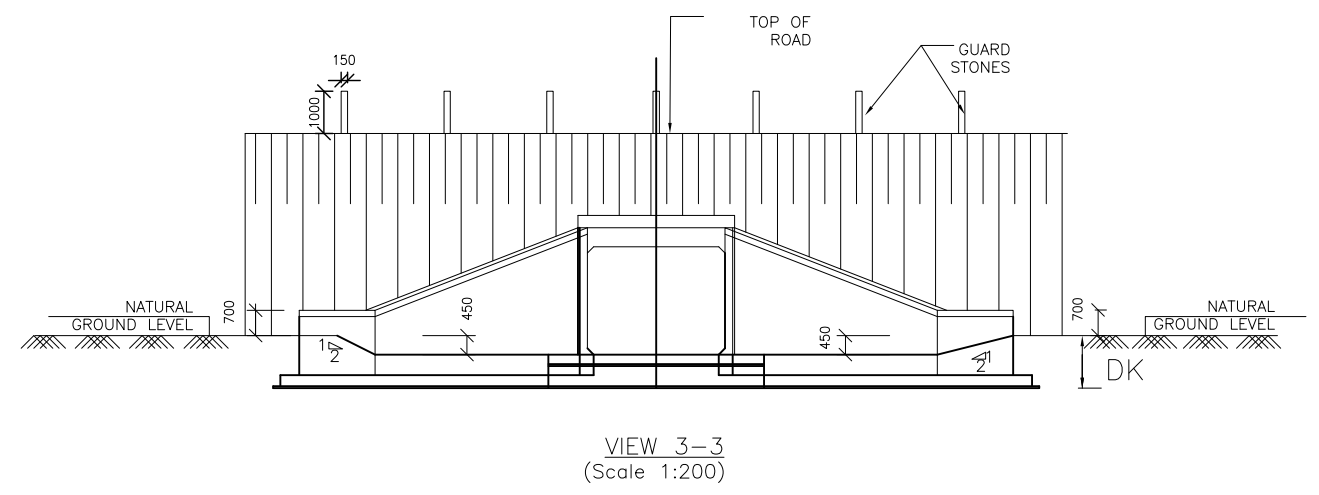
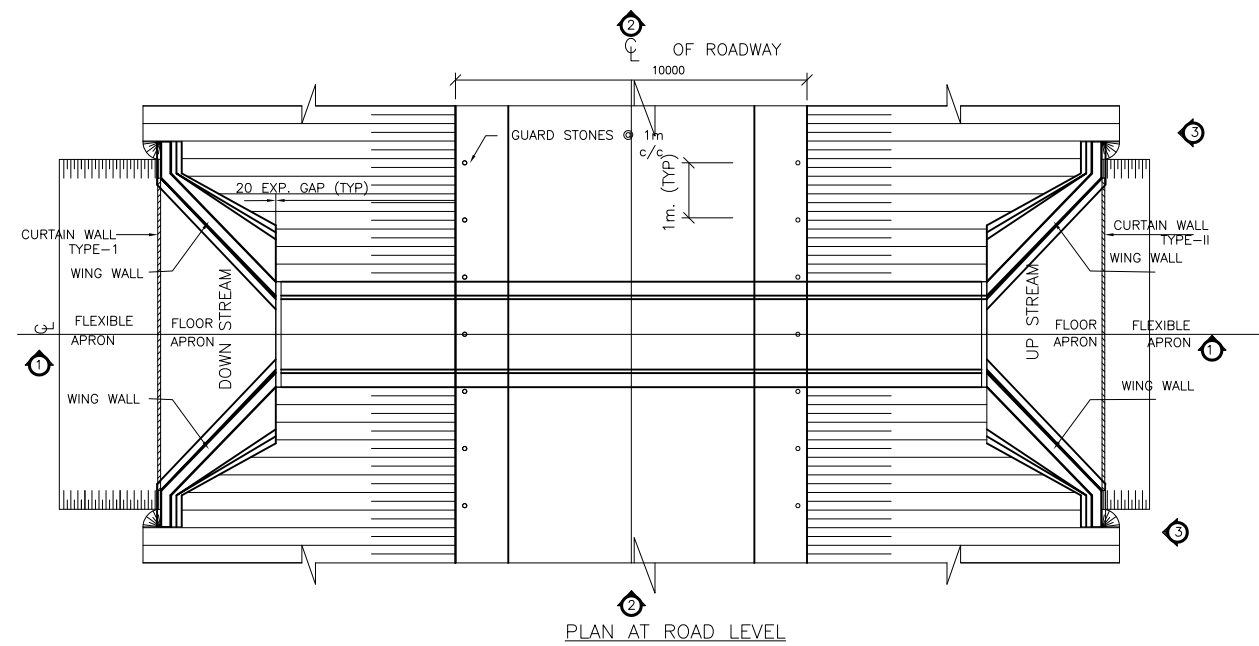
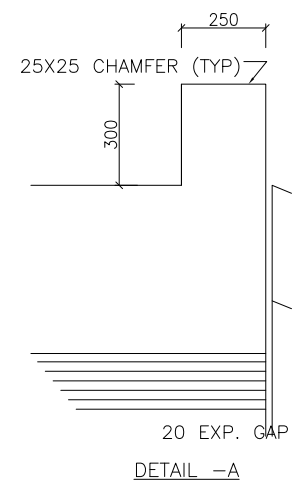
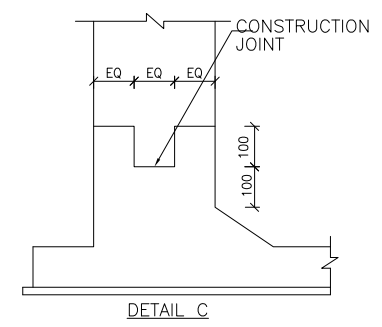
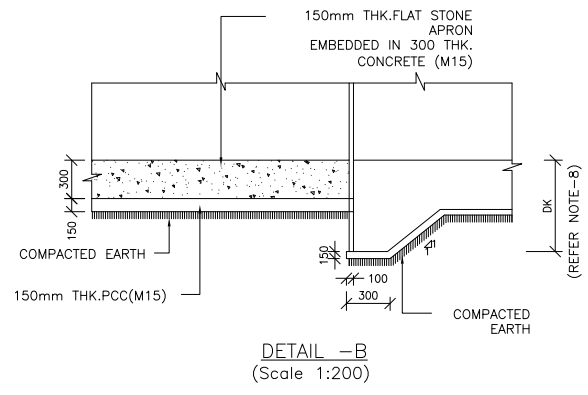

TABLE SHOWING SALIENT DIMENSIONS OF SINGLE CELL BOX CULVERT

Box Cell Designation	a (mm)	b (mm)	c (mm)	d (mm)	e (mm)	f (mm)	g (mm)	Design base Pressure t/m ²
2 m x 2 m	2000	2000	600	250	300	250	NA	8.8
3 m x 3 m	3000	3000	800	370	450	400	NA	11.6
4 m x 3 m	4000	3000	500	470	550	420	NA	10.1



Government of Nepal
Ministry of Physical Infrastructure & Transport
Department of Roads

STANDARD DRAWINGS FOR ROAD ELEMENTS

BOX CULVERT SINGLE CELL WITHOUT EARTH CUSHION

GENERAL DETAILS

Recommended by	Approved by	SHEET. NO. 36
Signature	Signature	
Designation	Designation	

Arjun Jung Thapa
Deputy Director General

Devendra Karki
Director General

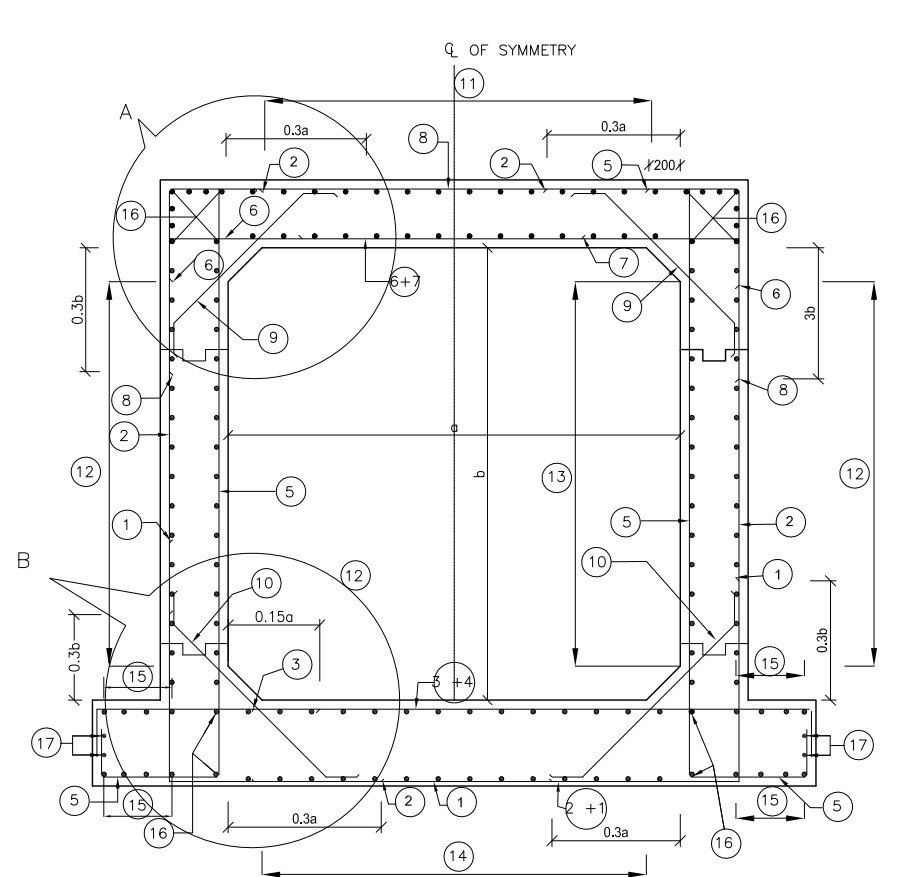

REINFORCEMENT DETAILS OF SINGLE CELL BOX CULVERT (with earth cushion)
(Scale 1:100)

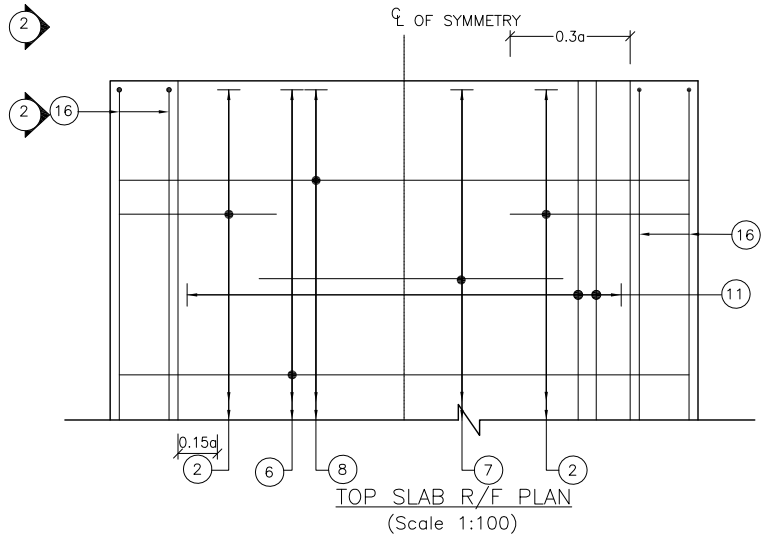

TOP SLAB R/F PLAN
(Scale 1:100)

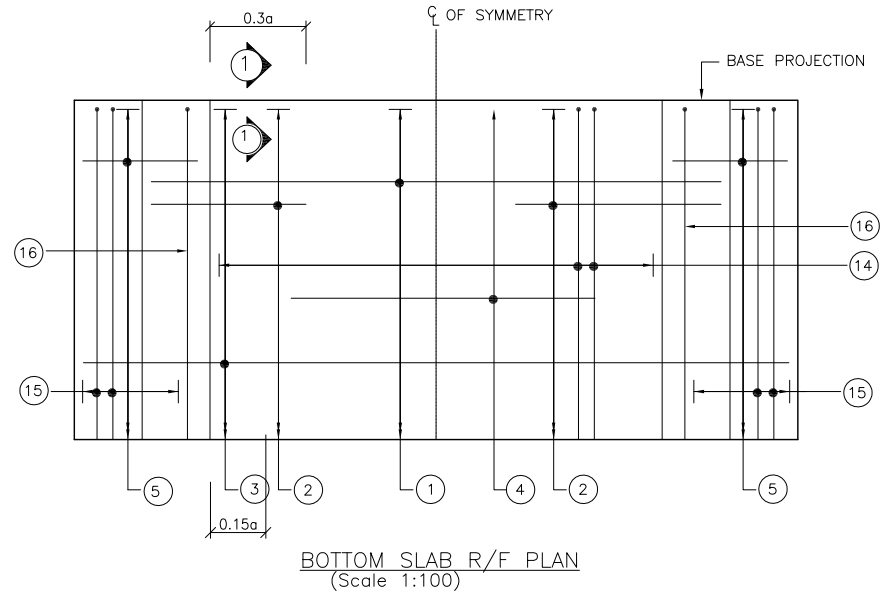

BOTTOM SLAB R/F PLAN
(Scale 1:100)

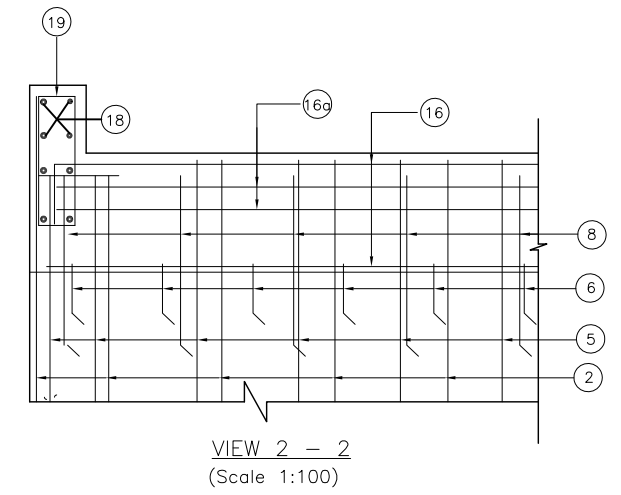

VIEW 2 - 2
(Scale 1:100)

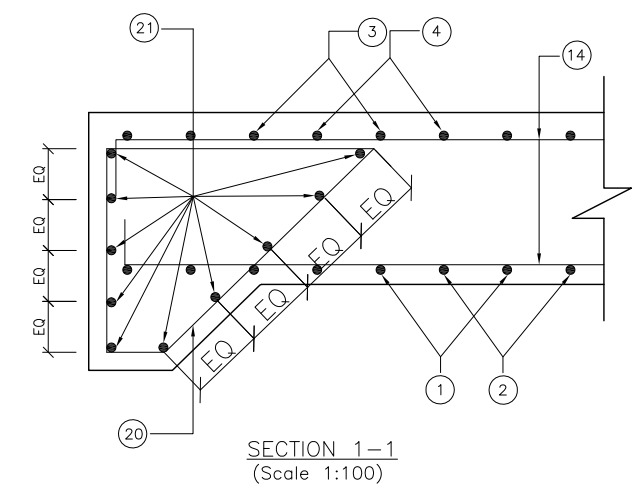

SECTION 1-1
(Scale 1:100)

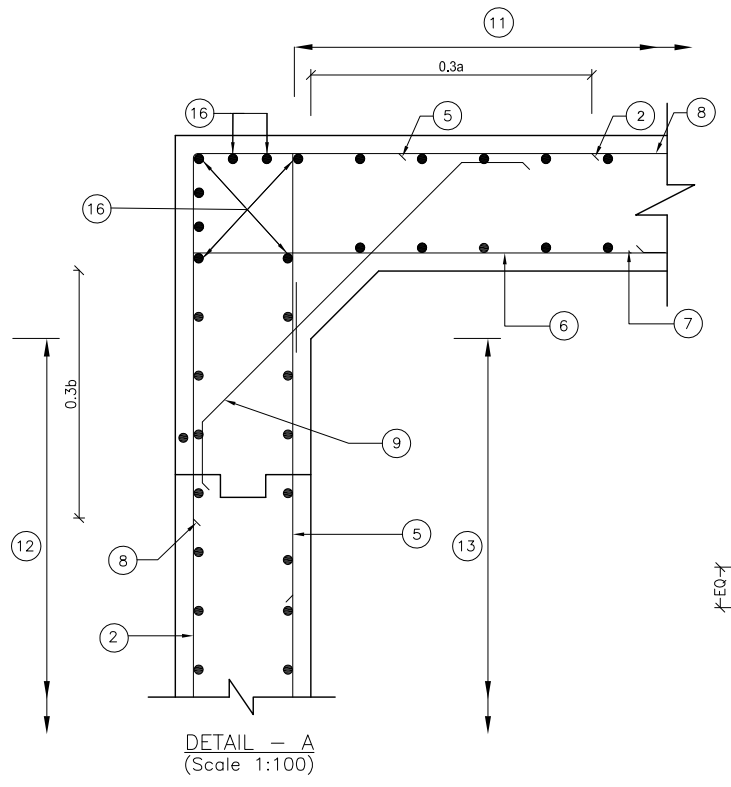

DETAIL - A
(Scale 1:100)

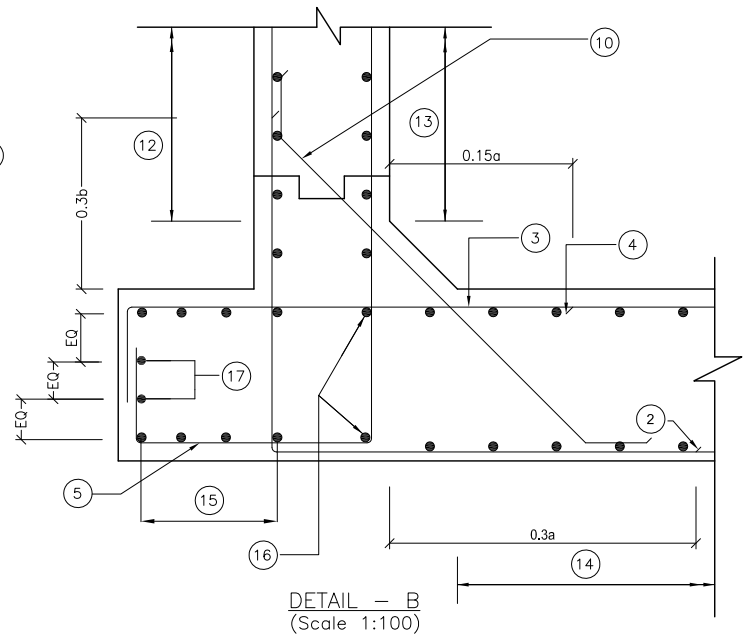

DETAIL - B
(Scale 1:100)

NOTES:

1. For General notes refer Drg. No. 01
2. For General arrangement refer Drg.No. 02
3. For Bar bending schedule refer Drg.No. 04

LEGEND:

- : TOP FACE BARS / OUTER FACE BARS
- - - - - : BOTTOM FACE BARS / INNER FACE BARS

Government of Nepal Ministry of Physical Infrastructure & Transport Department of Roads			
STANDARD DRAWINGS FOR ROAD ELEMENTS			
SINGLE CELL BOX CULVERT WITHOUT EARTH CUSHION			
REINFORCEMENT DETAILS			
	Recommended by	Approved by	
Signature			SHEET. NO. 37
	Arjun Jung Thapa	Devendra Karki	
Designation	Deputy Director General	Director General	

BAR MARK	SHAPE OF BARS (NOT TO SCALE)	Single Cell Box Culvert 2m x2m with 3 m earth cushion									Single Cell Box Culvert 3m x3m with 3 m earth cushion									Single Cell Box Culvert 4m x3m with 3 m earth cushion									
		BAR DIA. in mm.	SPACING in mm.	M1 in mm.	M2 in mm.	LENGTH in mm.	NO. OF BARS	TOTAL LENGTH in mm.	Wt./m, kg	Weight, kg	BAR DIA. in mm.	SPACING in mm.	M1 in mm.	M2 in mm.	LENGTH in mm.	NO. OF BARS	TOTAL LENGTH in mm.	Wt./m, kg	Weight, kg	BAR DIA. in mm.	SPACING in mm.	M1 in mm.	M2 in mm.	LENGTH in mm.	NO. OF BARS	TOTAL LENGTH in mm.	Wt./m, kg	Weight, kg	
1		10	200	890	2400	4180	112	468160	0.62	290.3	12	200	1300	3700	6300	112	705600	0.62	437.5	12	240	1400	4740	7540	94	708760	0.89	630.8	
2		10	200	800	2450	4050	224	907200	0.62	562.5	12	200	1250	3720	6220	224	1393280	0.62	863.8	16	240	1570	3920	7060	188	1327280	1.58	2097.1	
3		12	125	200	3600	4000	180	720000	0.89	640.8	16	125	350	5300	6000	150	900000	0.89	801.0	20	200	450	5740	6640	112	743680	2.471	836.89	
4		Bar not used									Bar not used									10	200	2800	0	2800	112	313600	0.62	194.4	
5		10	200	2450	750	3600	224	806400	0.62	500.0	10	200	3720	1100	5220	180	939600	0.62	582.6	10	200	3920	820	5140	224	1151360	0.62	713.84	
6		10	100	160	2400	2720	225	612000	0.62	379.4	16	180	260	3700	4220	125	527500	0.62	327.1	20	220	320	4740	5380	103	554140	2.471	368.72	
7		Bar not used									Bar not used									10	220	2800	0	2800	103	288400	0.62	178.8	
8		10	200	800	2400	4000	112	448000	0.62	277.8	12	200	1220	3700	6140	112	687680	0.62	426.4	12	240	1320	4740	7380	94	693720	0.89	617.4	
9		10	200	200	870	1270	224	284480	0.62	176.4	10	200	200	1060	1460	224	327040	0.62	202.8	10	240	200	1220	1620	188	304560	0.62	188.8	
10		10	200	200	870	1270	224	284480	0.62	176.4	10	200	200	1170	1570	224	351680	0.62	218.0	10	240	200	1340	1740	188	327120	0.62	202.8	
11		10	250	160	22400	22720	16	363520	0.62	225.4	10	250	200	22400	22800	24	547200	0.62	339.3	10	200	200	22400	22800	40	912000	0.62	565.4	
12		10	250	160	22400	22720	16	363520	0.62	225.4	10	250	200	22400	22800	24	547200	0.62	339.3	10	200	200	22400	22800	30	684000	0.62	424.1	
13		10	250	160	22400	22720	16	363520	0.62	225.4	10	250	200	22400	22800	24	547200	0.62	339.3	10	250	200	22400	22800	24	547200	0.62	339.3	
14		10	250	160	22400	22720	16	363520	0.62	225.4	10	250	200	22400	22800	24	547200	0.62	339.3	10	200	200	22400	22800	24	547200	0.62	339.3	
15		10	250	160	22400	22720	16	363520	0.62	225.4	10	250	200	22400	22800	20	456000	0.62	282.7	10	200	200	22400	22800	40	912000	0.62	565.4	
16		10	-	160	22400	22720	12	272640	0.89	242.6	10	-	200	22400	22800	12	273600	0.89	243.5	10	-	160	22400	22720	12	272640	0.62	169.03	
17		Bar not used									10	-	160	22400	22720	2	45440	0.62	28.1	10	-	160	22400	22720	2	45440	0.62	28.17	
18		10	150	150	450	1200	34	40800	0.62	25.3	10	150	150	450	1200	52	62400	0.62	38.7	10	150	150	670	1640	66	108240	0.62	67.1	
19		10	-	160	2400	2720	16	43520	0.62	27.0	10	-	160	2900	3220	16	51520	0.62	31.9	10	-	160	4740	5060	16	80960	0.62	50.2	
20		10	150	1100	1550	4150	34	141100	0.62	87.5	10	150	1100	1550	4150	52	215800	0.62	133.8	10	150	1100	1550	4150	66	273900	0.62	169.8	
21		12	-	200	2400	2800	20	56000	0.89	49.8	12	-	200	2900	3300	20	66000	0.89	58.7	12	-	200	4740	5140	20	102800	0.89	91.5	
									4337.20										6033.80										10838.85

NOTES:

1. Joint or lapping of bars shall be suitably Staggered as per clause 304.6 of IRC: 21-2000.
2. This Drawing shall be read in conjunction with other relevant Drawings.
3. Quantity of steel includes 5% extra for wastage and laps.
4. Quantity of steel are for per metre width.

 Government of Nepal Ministry of Physical Infrastructure & Transport Department of Roads			
STANDARD DRAWINGS FOR ROAD ELEMENTS			
BOX CULVERT SINGLE CELL WITH 3M EARTH CUSHION			
BAR BENDING SCHEDULE			
Signature	Recommended by	Approved by	SHEET. NO. 38
	Arjun Jung Thapa	Devendra Karki	
Designation	Deputy Director General	Director General	

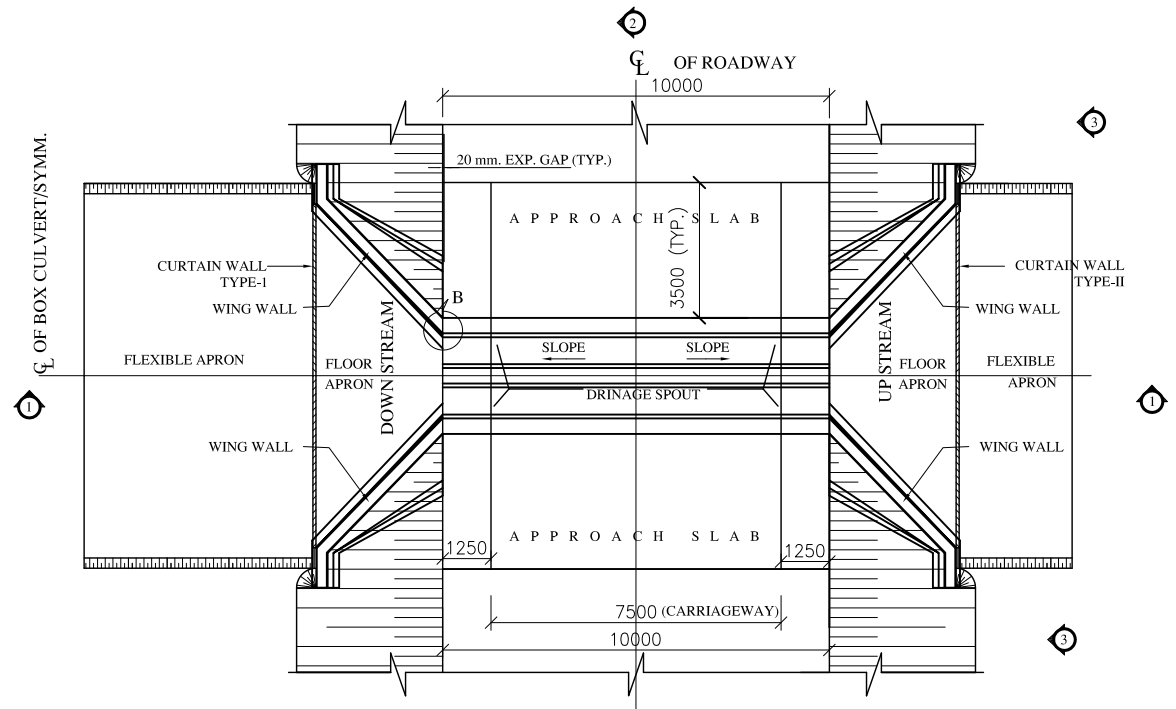

PLAN AT ROAD LEVEL

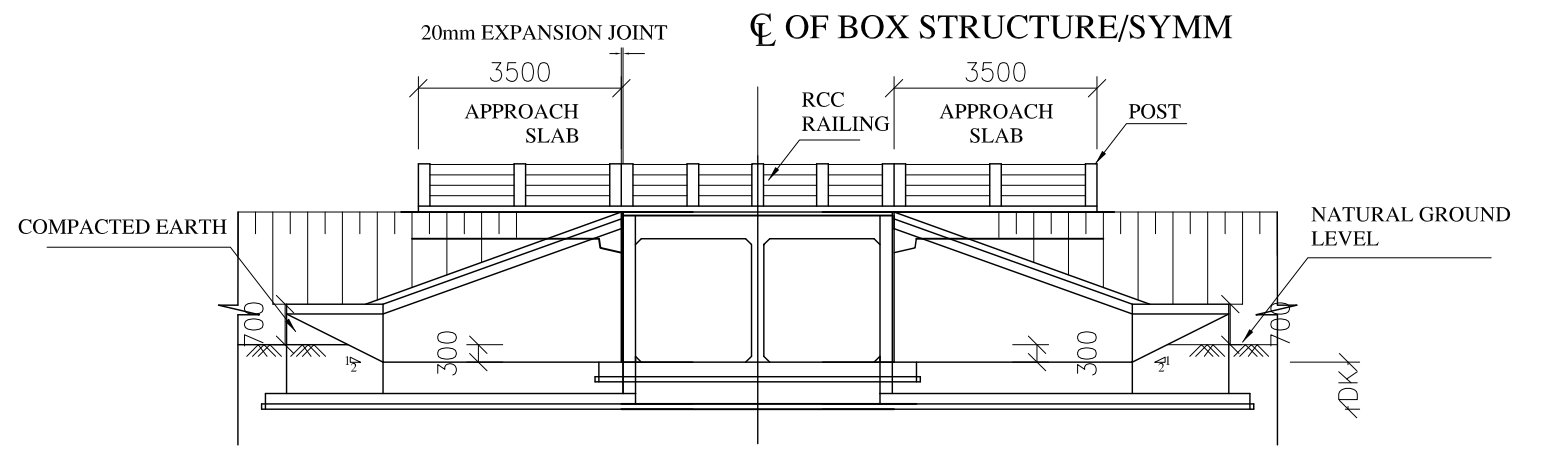

VIEW 3-3

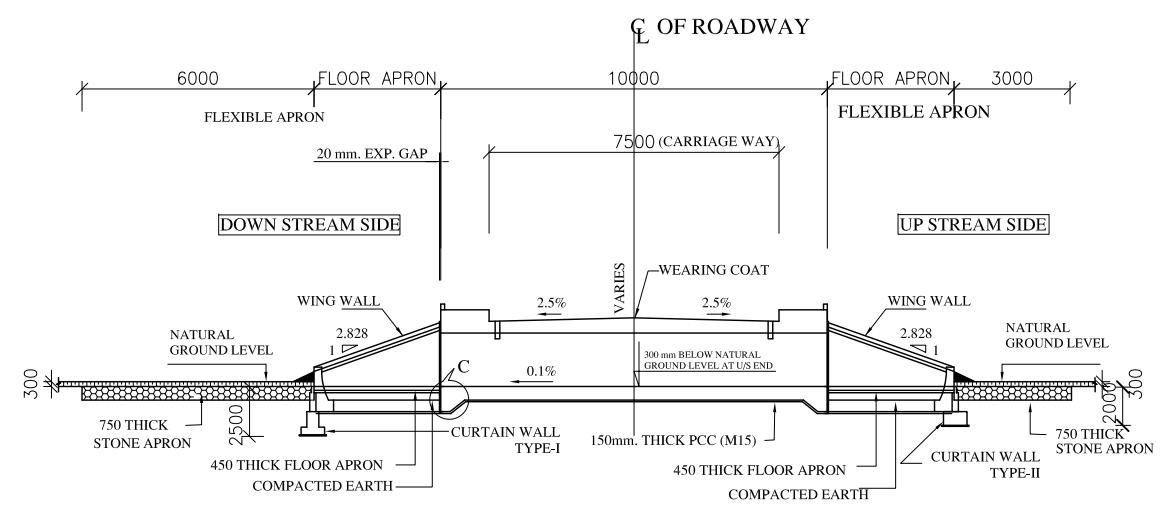

SECTION 1-1

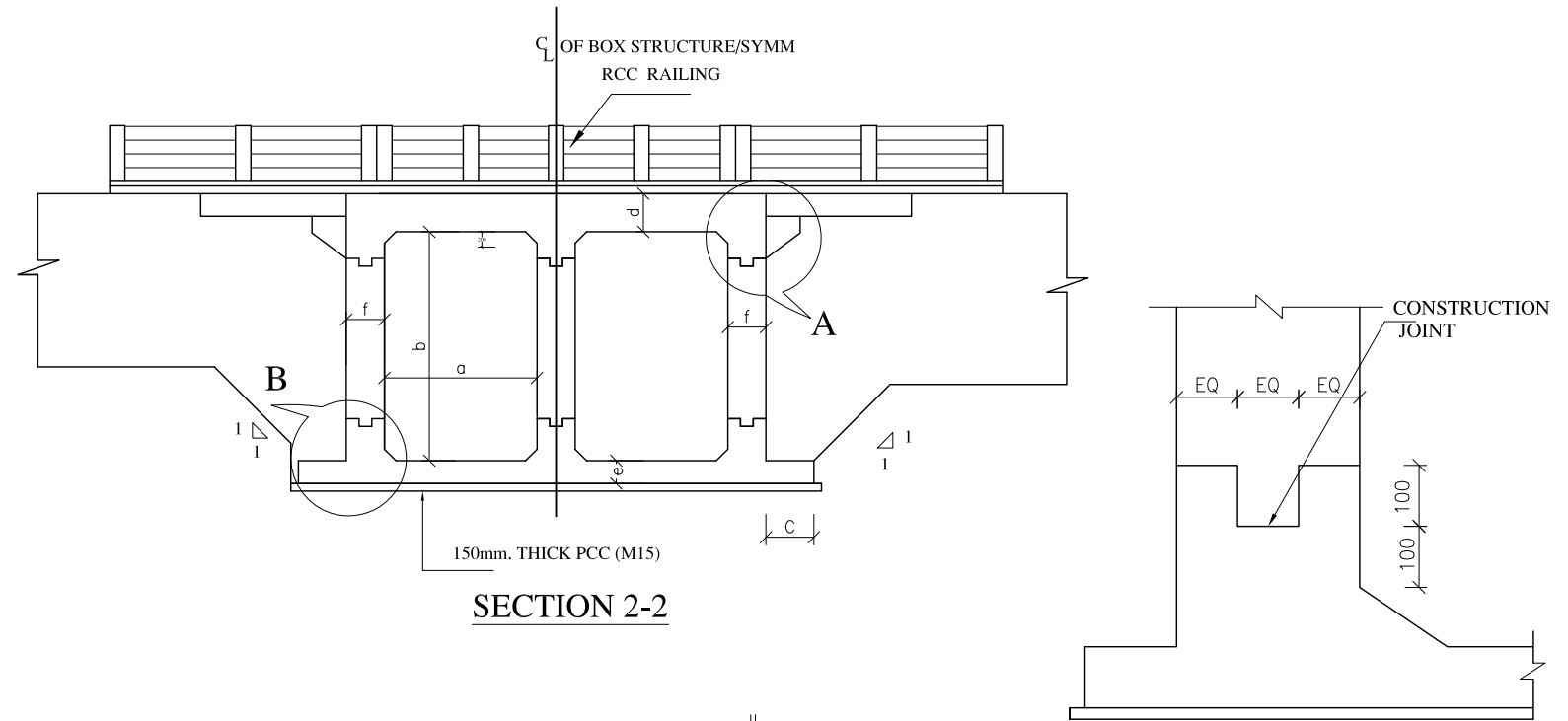

SECTION 2-2

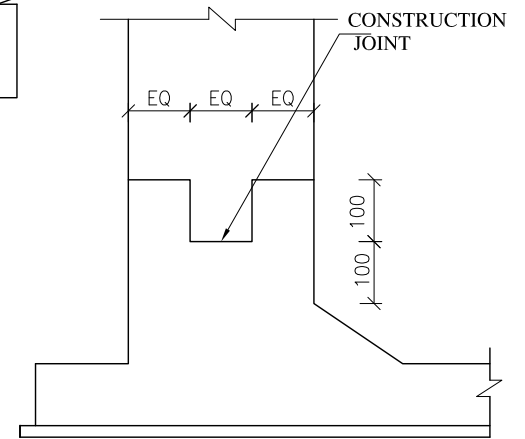

DETAIL B

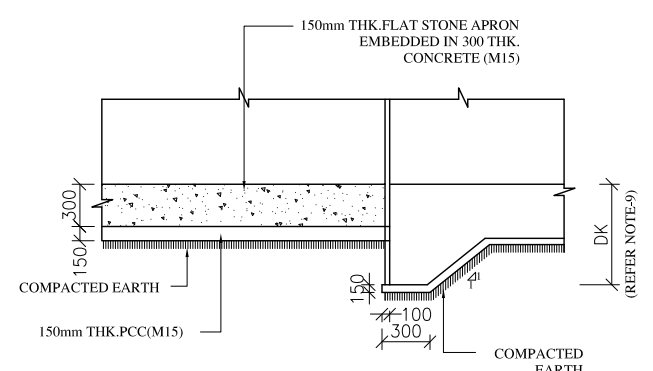

DETAIL -C
(Scale 1:200)

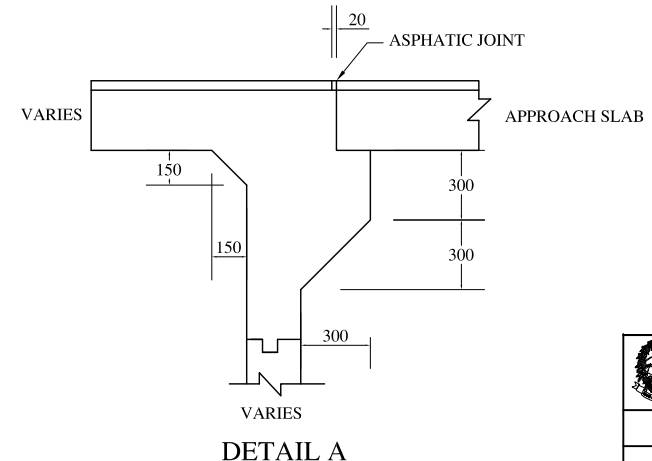

DETAIL A

TABLE SHOWING SALIENT DIMENSIONS OF DOUBLE CELL BOX CULVERT

Box Cell Designation	a (mm)	b (mm)	c (mm)	d (mm)	e (mm)	f (mm)	g (mm)	h (mm)	Design base Pressure t/m ²
2 m x 2 m	2000	2000	300	400	400	370	300	NA	8.9
2 m x 3 m	2000	3000	300	400	420	400	300	NA	10.3
3 m x 2 m	3000	2000	300	450	450	400	300	NA	7.6
3 m x 3 m	3000	3000	300	470	450	420	350	NA	8.5

Government of Nepal
Ministry of Physical Infrastructure & Transport
Department of Roads

STANDARD DRAWINGS FOR ROAD ELEMENTS

BOX CULVERT DOUBLE CELL WITHOUT EARTH CUSHION

GENERAL DETAILS

Recommended by	Approved by	SHEET. NO. 39
Signature: Arjun Jung Thapa	Signature: Devendra Karki	
Designation: Deputy Director General	Designation: Director General	

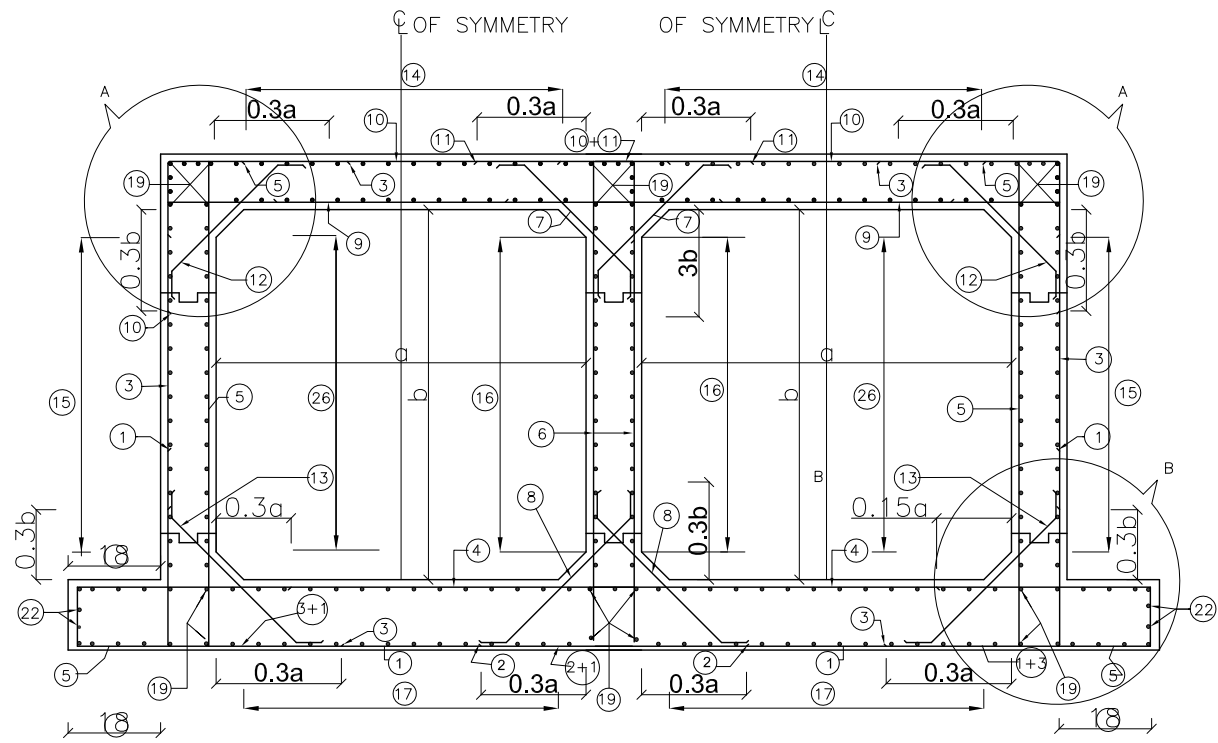

REINFORCEMENT DETAILS OF DOUBLE CELL BOX
CULVERT
(Scale 1:100)

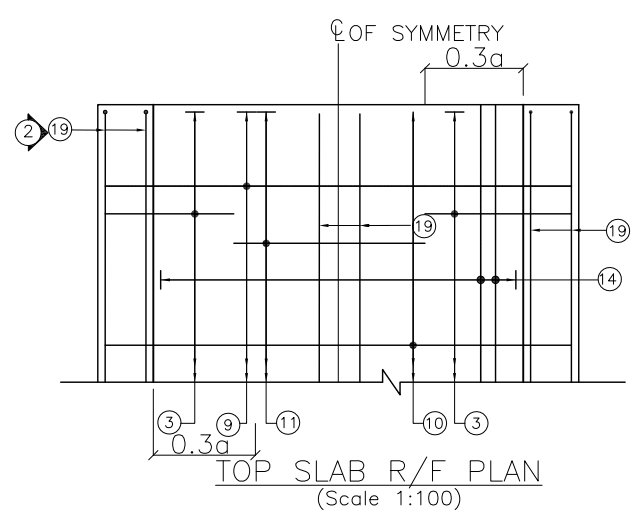

TOP SLAB R/F PLAN
(Scale 1:100)

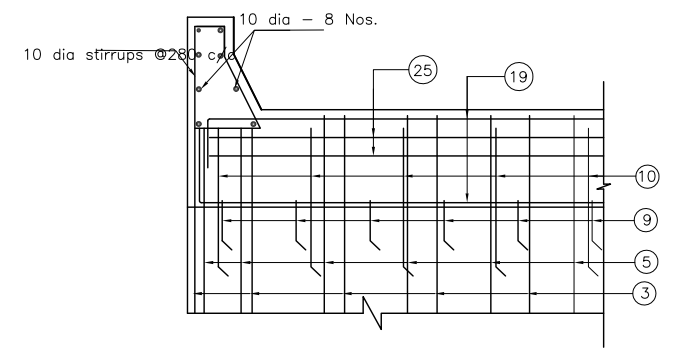

VIEW 2 - 2
(Scale 1:100)

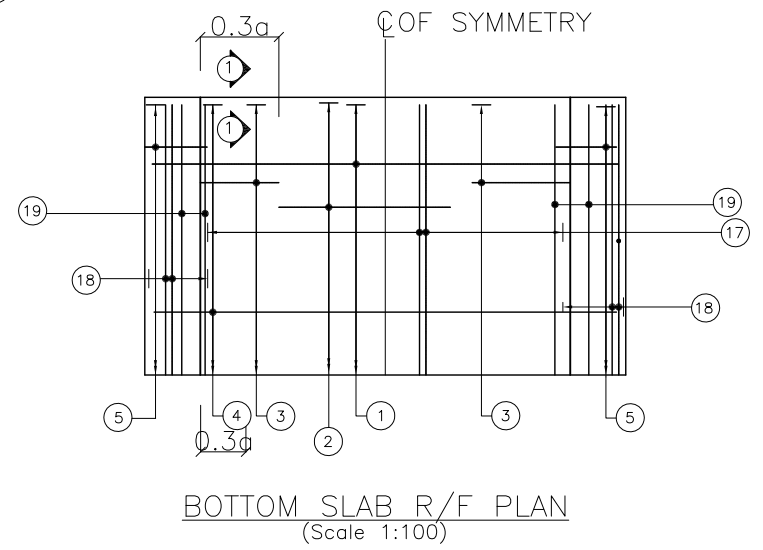

BOTTOM SLAB R/F PLAN
(Scale 1:100)

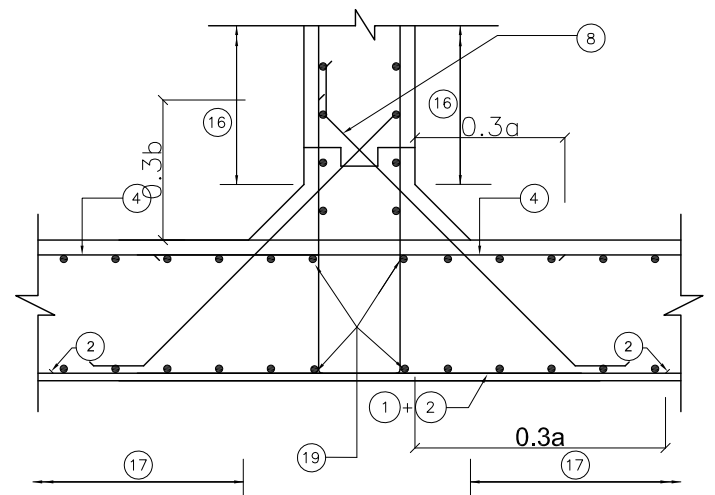

DETAIL - C
(Scale 1:100)

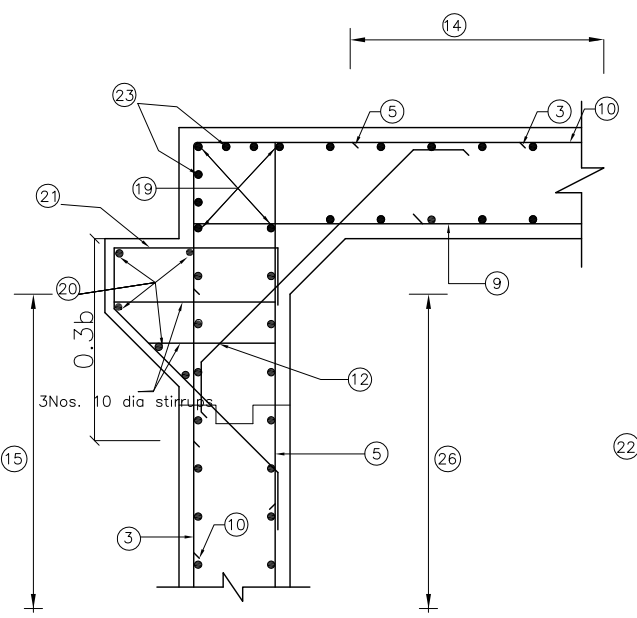

DETAIL - A
(Scale 1:100)

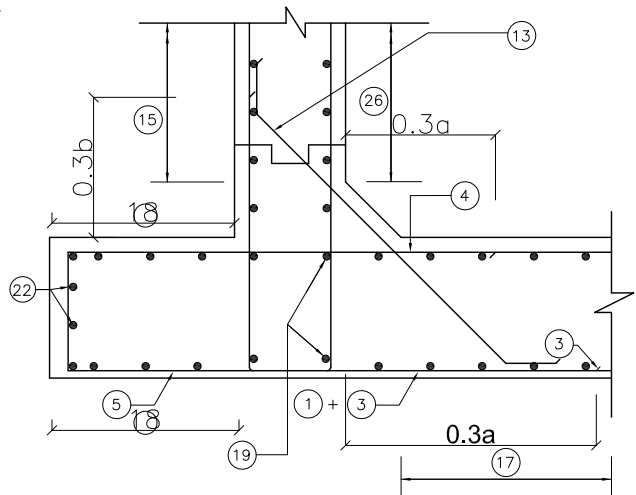

DETAIL - B
(Scale 1:100)

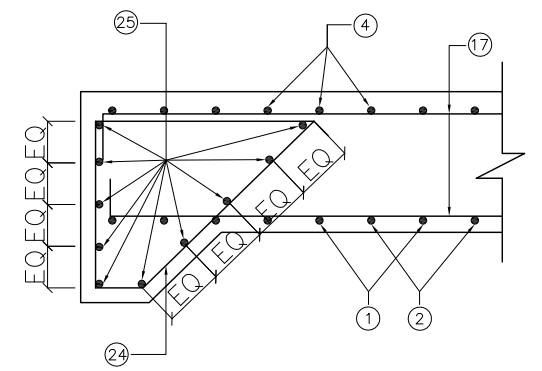

SECTION 1-1
(Scale 1:100)

NOTES:

1. FOR GENERAL NOTES REFER DRG. NO.
2. FOR GENERAL ARRANGEMENT REFER DRG.NO.
3. FOR BAR BENDING SCHEDULE REFER DRG. NO.
4. Bar required for kerbs and Railings are not included in the bar bending schedule.

LEGEND:

- : TOP FACE BARS / OUTER FACE BARS
- - - : BOTTOM FACE BARS / INNER FACE BARS

Government of Nepal Ministry of Physical Infrastructure & Transport Department of Roads			
STANDARD DRAWINGS FOR ROAD ELEMENTS			
DOUBLE CELL BOX CULVERT WITHOUT EARTH CUSHION			
REINFORCEMENT DETAILS			
Recommended by	Approved by		SHEET. NO. 40
Signature	Signature		
Arjun Jung Thapa	Devendra Karki		
Designation	Deputy Director General	Director General	

BAR MARK	BOX-CELL DESIGNATION No/ab/Ec SHAPE OF BARS (NOT TO SCALE)	Double Cell Box Culvert 2m x2m without earth cushion									Double Cell Box Culvert 2m x3m without earth cushion									Double Cell Box Culvert 3m x2m without earth cushion									Double Cell Box Culvert 3m x3m without earth cushion										
		BAR DIA. in mm.	SPACING in mm.	M1 in mm.	M2 in mm.	LENGTH in mm.	NO. OF BARS	TOTAL LENGTH in mm.	Wt/m, kg	Weight, kg	BAR DIA. in mm.	SPACING in mm.	M1 in mm.	M2 in mm.	LENGTH in mm.	NO. OF BARS	TOTAL LENGTH in mm.	Wt/m, kg	Weight, kg	BAR DIA. in mm.	SPACING in mm.	M1 in mm.	M2 in mm.	LENGTH in mm.	NO. OF BARS	TOTAL LENGTH in mm.	Wt/m, kg	Weight, kg	BAR DIA. in mm.	SPACING in mm.	M1 in mm.	M2 in mm.	LENGTH in mm.	NO. OF BARS	TOTAL LENGTH in mm.	Wt/m, kg	Weight, kg		
1		10	200	950	4940	6840	51	348840	0.62	216.3	10	200	1270	5000	7540	51	384540	0.62	238.4	10	200	1300	7000	9600	51	489600	0.62	303.6	10	200	1300	7090	9690	51	494190	0.62	306.4		
2		10	200	1500	0	1500	50	75000	0.62	46.5	10	200	1500	0	1500	50	75000	0.62	46.5	10	200	2100	0	2100	50	105000	0.62	65.1	10	200	2150	0	2150	50	107500	0.62	66.7		
3		12	200	920	2700	4540	102	463080	0.89	412.1	16	200	920	3720	5560	102	567120	1.58	896.0	16	200	1250	2800	5300	102	540600	1.58	854.1	16	200	1270	3820	6360	102	648720	1.58	1025.0		
4		12	150	300	5540	6240	67	418080	0.89	372.1	12	125	320	5600	6320	80	505600	0.89	450.0	16	200	350	7600	8350	51	425850	1.58	672.8	16	200	350	7690	8440	51	430440	1.58	680.1		
5		12	125	2700	570	5970	162	967140	0.89	860.8	12	175	3720	600	8040	116	932640	0.89	830.0	12	125	2800	600	6200	160	992000	0.89	882.9	20	200	3820	620	8260	162	1338120	2.47	3305.2		
6		16	200	260	2700	3220	102	328440	1.58	518.9	16	200	260	3720	4240	102	432480	1.58	683.3	12	125	200	2800	3200	160	512000	0.89	455.7	16	200	260	3820	4340	102	442680	1.58	699.4		
7		12	200	200	960	1360	102	138720	0.89	123.5	12	200	200	950	1350	102	137700	0.89	122.6	12	200	200	1030	1430	102	145860	0.89	129.8	12	200	200	1130	1530	102	156060	0.89	138.9		
8		12	200	200	960	1360	102	138720	0.89	123.5	12	200	200	990	1390	102	141780	0.89	126.2	12	200	200	1030	1430	102	145860	0.89	129.8	12	200	200	1100	1500	102	153000	0.89	136.2		
9		12	125	200	4940	5340	81	432540	0.89	385.0	12	125	200	5000	5400	81	437400	0.89	389.3	16	200	260	7000	7520	51	383520	1.58	606.0	16	200	260	7090	7610	51	388110	1.58	613.2		
10		10	200	950	4940	6840	51	348840	0.62	216.3	12	200	1250	5000	7500	51	382500	0.62	237.2	12	200	1000	7000	9000	51	459000	0.89	408.5	12	200	1320	7090	9730	51	496230	0.89	441.6		
11		16	200	1500	0	1500	50	75000	1.58	118.5	16	200	1500	0	1500	50	75000	1.58	118.5	16	200	2100	0	2100	50	105000	1.58	165.9	20	200	2150	0	2150	60	129000	2.47	318.6		
12		12	200	200	1060	1460	102	148920	0.89	132.5	12	200	200	1100	1500	102	153000	0.89	136.2	12	200	200	1170	1570	102	160140	0.89	142.5	12	200	200	1230	1630	102	166260	0.89	148.0		
13		12	200	200	1060	1460	102	148920	0.89	132.5	12	200	200	1130	1530	102	156060	0.89	138.9	12	200	200	1170	1570	102	160140	0.89	142.5	12	200	200	1200	1600	102	163200	0.89	145.2		
14		8	150	200	9900	10300	46	473800	0.4	189.5	10	150	250	9900	10400	46	478400	0.62	296.6	10	150	250	9900	10400	72	748800	0.62	464.3	10	150	250	9900	10400	72	748800	0.62	464.3		
15		8	150	200	9900	10300	23	236900	0.4	94.8	10	150	200	9900	10300	35	360500	0.62	223.5	10	150	200	9900	10300	23	236900	0.62	146.9	10	150	210	9900	10320	36	371520	0.62	230.3		
16		8	150	200	9900	10300	24	247200	0.4	98.9	10	150	160	9900	10220	35	357700	0.62	221.8	10	150	160	9900	10220	23	235060	0.62	145.7	10	150	160	9900	10220	36	367920	0.62	228.1		
17		8	150	200	9900	10300	48	494400	0.4	197.8	10	150	210	9900	10320	48	495360	0.62	307.1	10	150	225	9900	10350	72	745200	0.62	462.0	10	150	220	9900	10340	72	744480	0.62	461.6		
18		8	150	200	9900	10300	10	103000	0.4	41.2	10	150	210	9900	10320	12	123840	0.62	76.8	10	150	225	9900	10350	12	124200	0.62	77.0	10	150	220	9900	10340	12	124080	0.62	76.9		
19		10	-	160	9900	10220	16	163520	0.62	101.4	10	-	160	9900	10220	16	163520	0.62	101.4	10	-	160	9900	10220	16	163520	0.62	101.4	10	-	160	9900	10220	16	163520	0.62	101.4		
20		12	-	9900	0	9900	10	99000	0.89	88.1	12	-	9900	0	9900	10	99000	0.89	88.1	12	-	9900	0	9900	10	99000	0.89	88.1	12	-	9900	0	9900	10	99000	0.89	88.1		
21		12	200	1000	1260	2260	99	223740	0.89	199.1	12	200	1000	1260	2260	99	223740	0.89	199.1	12	200	1000	1260	2260	102	230520	0.89	205.2	12	200	1000	1260	2260	102	230520	0.89	205.2		
22		10	-	160	9900	10220	2	20440	0.62	12.7	10	-	160	9900	10220	2	20440	0.62	12.7	10	-	160	9900	10220	2	20440	0.62	12.7	10	-	160	9900	10220	2	20440	0.62	12.7		
23		10	-	180	9900	10260	4	41040	0.62	25.4	10	-	180	9900	10260	4	41040	0.62	25.4	10	-	160	9900	10220	4	40880	0.62	25.3	10	-	160	9900	10220	4	40880	0.62	25.3		
24		10	150	1100	1550	4150	76	315400	0.62	195.5	10	150	1100	1550	4150	76	315400	0.62	195.5	10	150	1100	1550	4150	102	423300	0.62	262.4	10	150	1100	1550	4150	104	431600	0.62	267.6		
25		10	-	160	5540	5860	20	117200	0.62	72.7	10	-	160	5600	5920	20	118400	0.62	73.4	10	-	160	7600	7920	20	158400	0.62	98.2	10	-	160	5540	5860	20	117200	0.62	72.7		
26		10	250	180	9900	10260	16	164160	0.62	101.8	10	250	200	9900	10300	16	164800	0.62	102.2	10	250	200	9900	10300	16	164800	0.62	102.2	10	250	210	9900	10320	16	165120	0.62	102.4		
									5077.3										6336.7										7150.7										10361.0

NOTES:

1. Joint or lapping of bars shall be suitably Staggered as per clause 304.6 of IRC: 21-2000.
2. This Drawing shall be read in conjunction with other relevant Drawings.
3. Quantity of steel includes 5% extra for wastage and laps.
4. Quantity of steel are for per metre width.

Government of Nepal Ministry of Physical Infrastructure & Transport Department of Roads			
STANDARD DRAWINGS FOR ROAD ELEMENTS			
BOX CULVERT DOUBLE CELL NO EARTH CUSHION			
BAR BENDING SCHEDULE			
	Recommended by	Approved by	
Signature			SHEET. NO. 41
Designation	Deputy Director General	Director General	

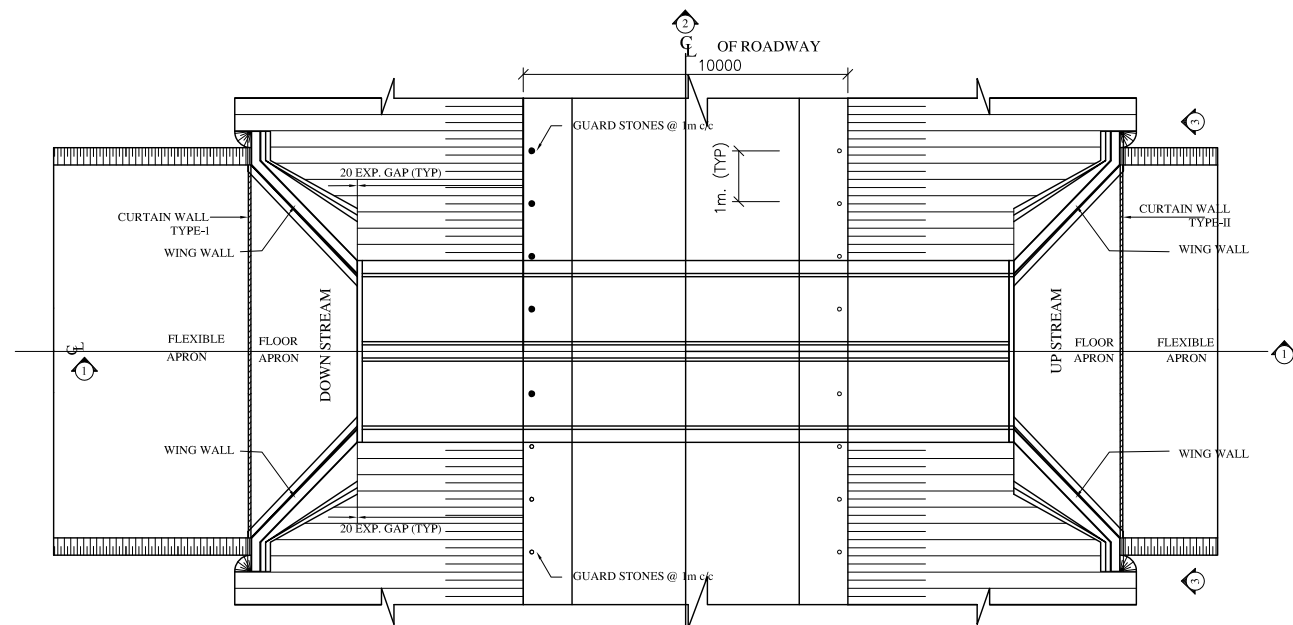

PLAN AT ROAD LEVEL
(Scale 1:200)

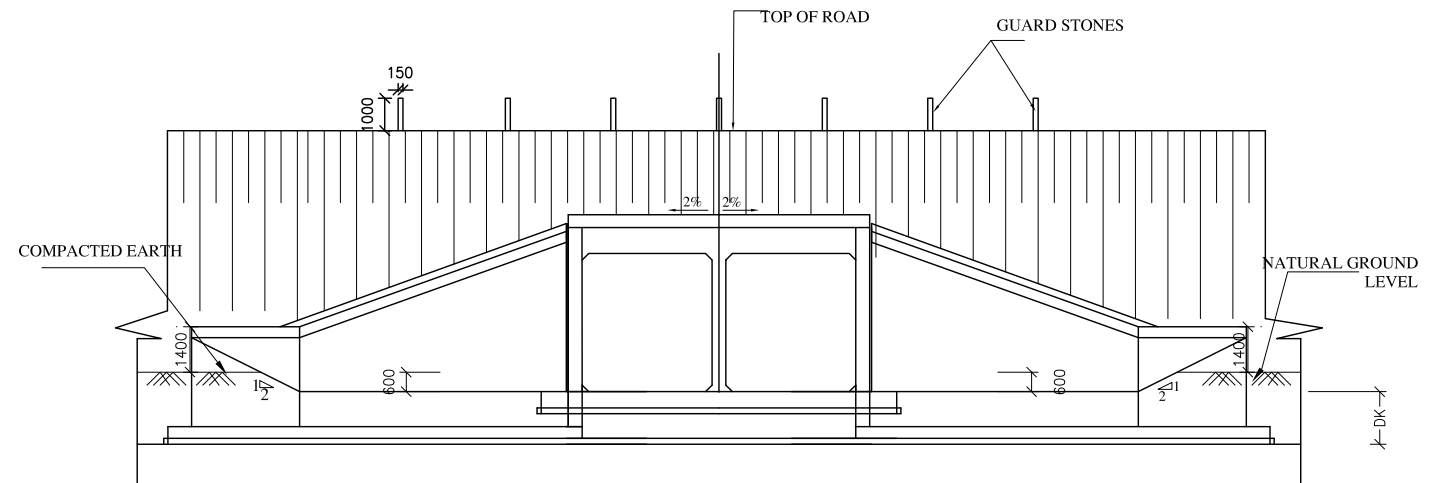

VIEW 3-3
(Scale 1:200)

DK(REFER NOTE-11)

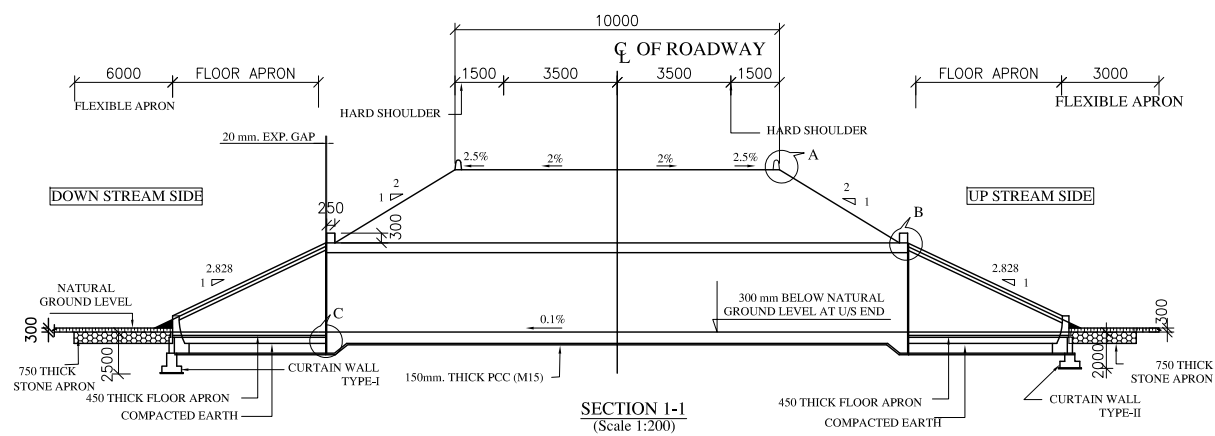

SECTION 1-1
(Scale 1:200)

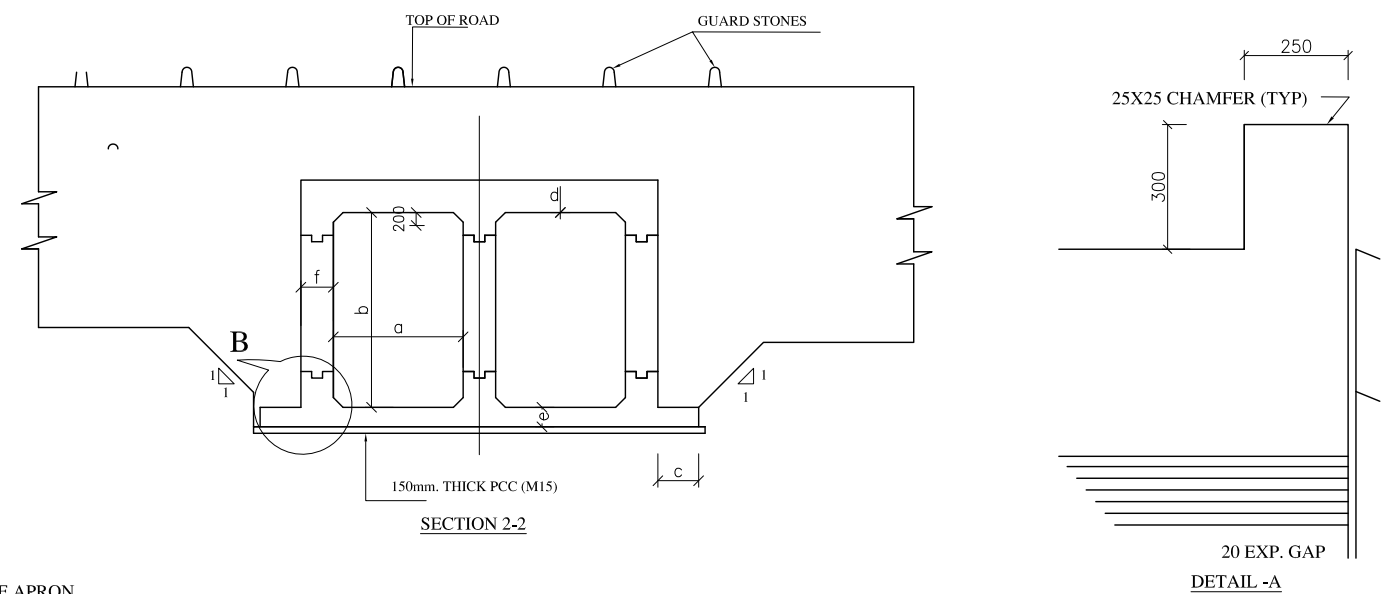

SECTION 2-2

DETAIL -A

TABLE SHOWING SALIENT DIMENSIONS OF DOUBLE CELL BOX CULVERT

Box Cell Designation	a (mm)	b (mm)	c (mm)	d (mm)	e (mm)	f (mm)	g (mm)	Design base Pressure t/m ²
2 m x 2 m	2000	2000	300	270	300	250	300	7.7
3 m x 2 m	3000	2000	300	400	420	300	250	7.9
3 m x 3 m	3000	3000	300	400	420	350	250	8.5

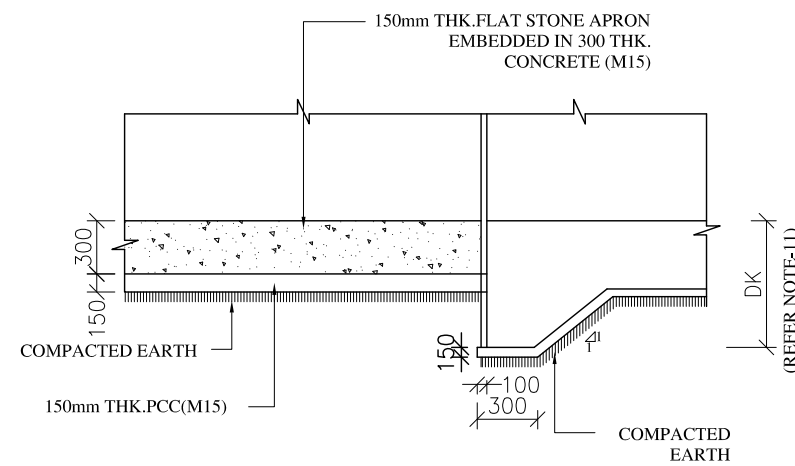

DETAIL -C
(Scale 1:200)

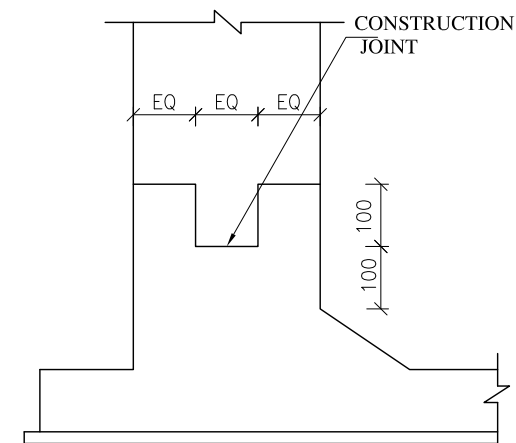

DETAIL B

Government of Nepal Ministry of Physical Infrastructure & Transport Department of Roads			
STANDARD DRAWINGS FOR ROAD ELEMENTS			
BOX CULVERT DOUBLE CELL WITH 3M EARTH CUSHION			
GENETAL DETAILS			
Recommended by	Approved by		SHEET. NO. 42
Signature	Signature		
Designation	Designation		
Arjun Jung Thapa	Devendra Karli		
Deputy Director General	Director General		

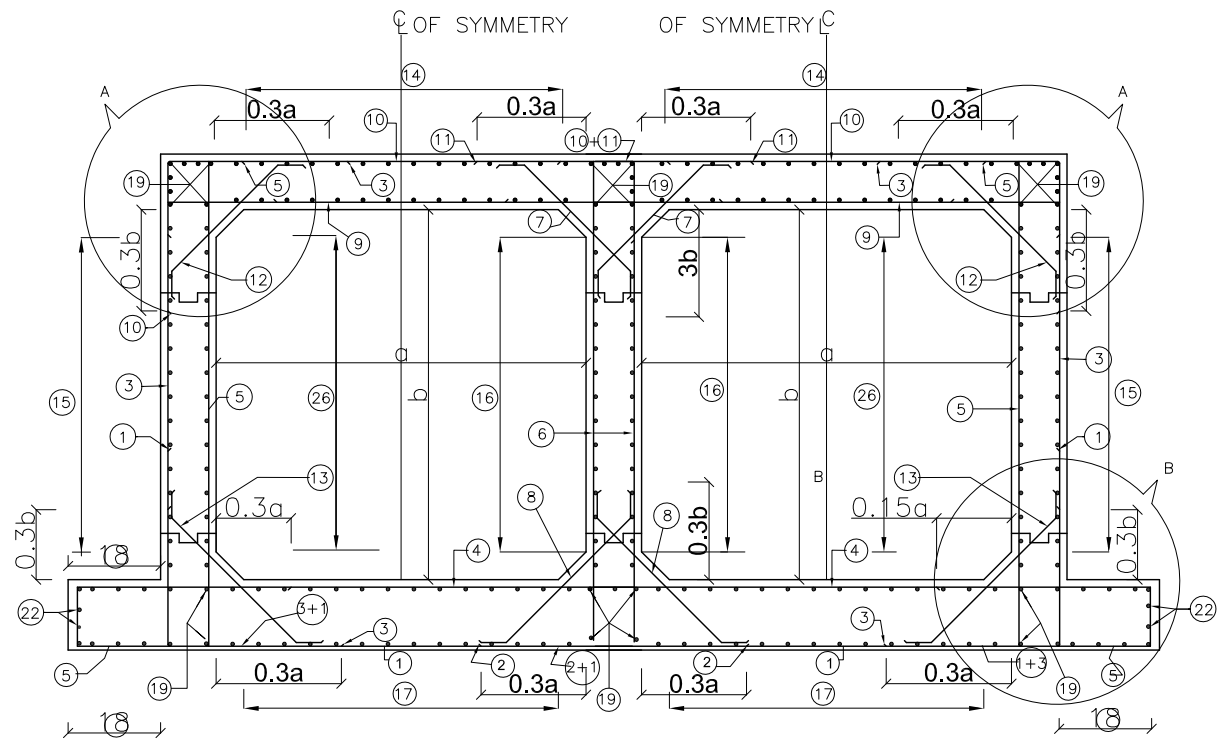

REINFORCEMENT DETAILS OF DOUBLE CELL BOX CULVERT
(Scale 1:100)

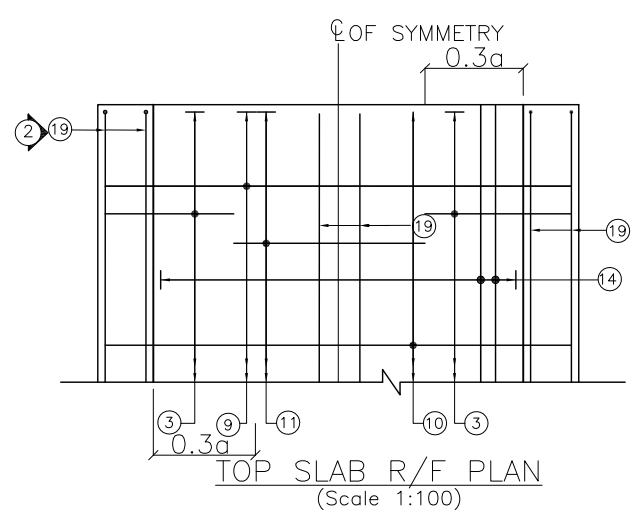

TOP SLAB R/F PLAN
(Scale 1:100)

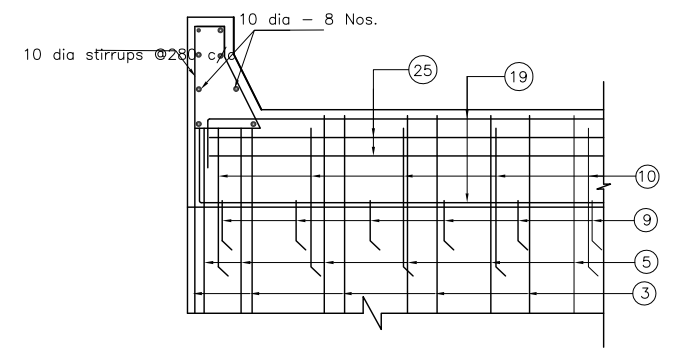

VIEW 2 - 2
(Scale 1:100)

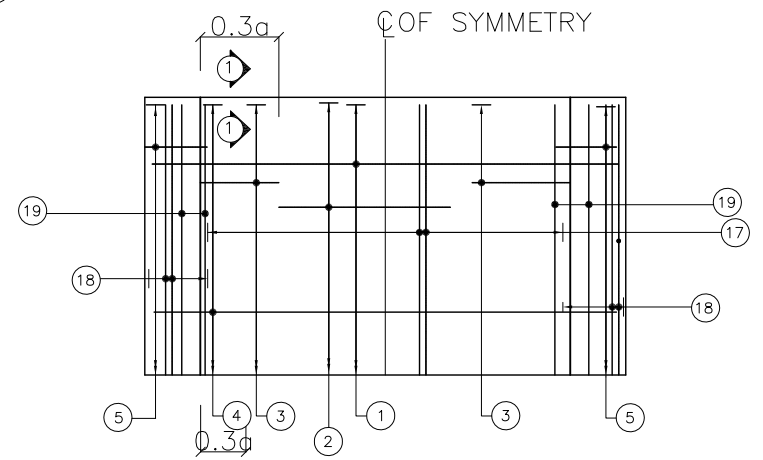

BOTTOM SLAB R/F PLAN
(Scale 1:100)

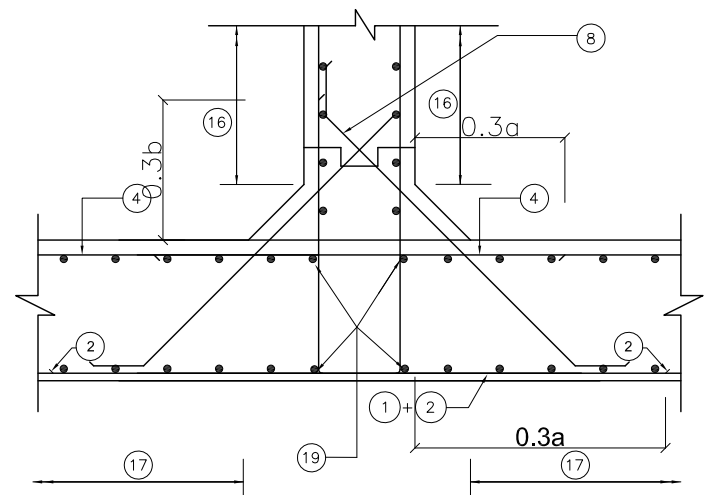

DETAIL - C
(Scale 1:100)

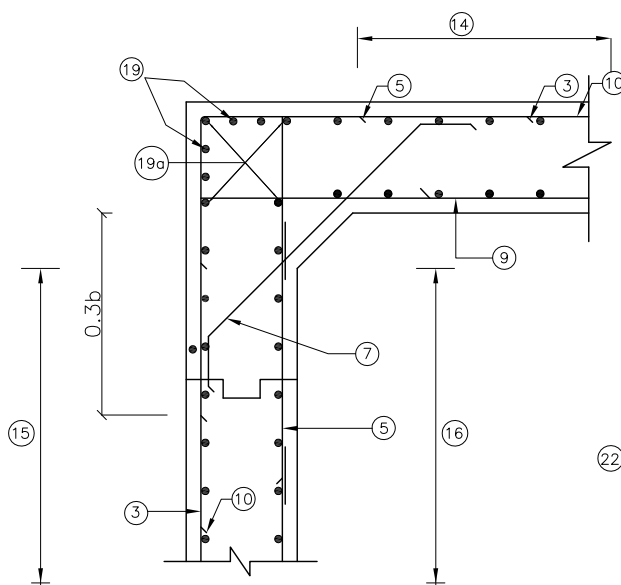

DETAIL - A
(Scale 1:100)

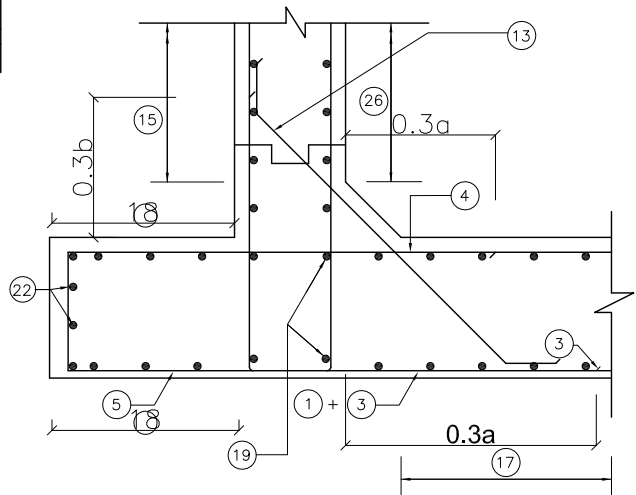

DETAIL - B
(Scale 1:100)

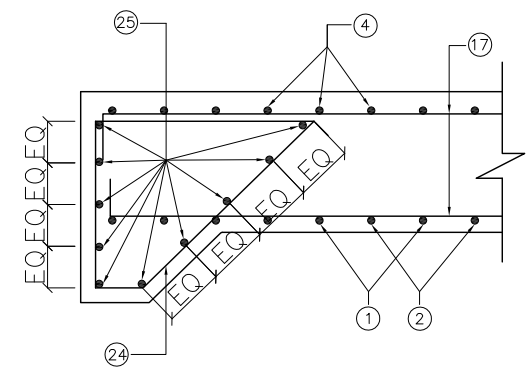

SECTION 1-1
(Scale 1:100)

NOTES:

1. FOR GENERAL NOTES REFER DRG. NO.
2. FOR GENERAL ARRANGEMENT REFER DRG.NO.
3. FOR BAR BENDING SCHEDULE REFER DRG. NO.
4. Bar required for kerbs and Railings are not included in the bar bending schedule.

LEGEND:

- : TOP FACE BARS / OUTER FACE BARS
- - - : BOTTOM FACE BARS / INNER FACE BARS

Government of Nepal Ministry of Physical Infrastructure & Transport Department of Roads			
STANDARD DRAWINGS FOR ROAD ELEMENTS			
DOUBLE CELL BOX CULVERT WITH 3M EARTH CUSHION			
REINFORCEMENT DETAILS			
Recommended by	Approved by		SHEET NO. 43
Signature	Signature		
Arjun Jung Thapa	Devendra Karki		
Designation	Deputy Director General	Director General	

BAR MARK	BOX-CELL DESIGNATION Nc/lab/Ec SHAPE OF BARS (NOT TO SCALE)	Double Cell Box Culvert 2m x2m with 3m earth cushion									Double Cell Box Culvert 2m x3m with 3m earth cushion									Double Cell Box Culvert 3m x3m with 3m earth cushion									
		BAR DIA. in mm.	SPACING in mm.	M1 in mm.	M2 in mm.	LENGTH in mm.	NO. OF BARS	TOTAL LENGTH in mm.	Wt/m, kg	Weight, kg	BAR DIA. in mm.	SPACING in mm.	M1 in mm.	M2 in mm.	LENGTH in mm.	NO. OF BARS	TOTAL LENGTH in mm.	Wt/m, kg	Weight, kg	BAR DIA. in mm.	SPACING in mm.	M1 in mm.	M2 in mm.	LENGTH in mm.	NO. OF BARS	TOTAL LENGTH in mm.	Wt/m, kg	Weight, kg	
1		12	240	850	4650	6350	94	596900	0.89	531.2	12	250	970	6750	8690	90	782100	0.89	696.1	12	200	1270	6850	9390	113	1061070	0.89	944.4	
2		12	240	1450	0	1450	93	134850	0.89	120.0	16	250	2050	0	2050	89	182450	1.58	288.3	12	200	2050	0	2050	112	229600	0.89	204.3	
3		10	240	800	2470	4070	188	765160	0.62	474.4	12	250	1150	2720	5020	180	903600	0.89	804.2	12	200	1200	3720	6120	226	1383120	0.89	1231.0	
4		10	125	200	4650	5250	180	945000	0.62	585.9	12	120	320	6750	7470	188	1404360	0.89	1249.9	16	200	320	6850	7570	113	855410	1.58	1351.5	
5		10	200	2470	450	3320	226	750320	0.62	465.2	10	200	2720	500	3620	226	818120	0.62	507.2	10	200	3720	550	4670	224	1046080	0.62	648.6	
6		10	250	160	2470	2790	190	530100	0.62	328.7	10	250	160	2720	3040	190	577600	0.62	358.1	10	250	160	3720	4040	180	727200	0.62	450.9	
7		10	240	200	700	1100	188	206800	0.62	128.2	10	250	200	960	1360	180	244800	0.62	151.8	10	200	200	1030	1430	224	320320	0.62	198.6	
8		10	240	200	750	1150	188	216200	0.62	134.0	10	250	200	990	1390	180	250200	0.62	155.1	10	200	200	1060	1460	224	327040	0.62	202.8	
9		12	220	200	4640	5040	103	519120	0.89	462.0	12	150	200	6740	7140	150	1071000	0.89	953.2	12	170	200	6840	7240	132	955680	0.89	850.6	
10		10	240	820	4650	6290	94	591260	0.62	366.6	12	250	820	6750	8390	90	755100	0.89	672.0	12	200	1250	6850	9350	113	1056550	0.89	940.3	
11		16	240	1450	0	1450	94	136300	1.58	215.4	16	250	2050	0	2050	89	182450	1.58	288.3	16	200	2050	0	2050	112	229600	1.58	362.8	
12		10	240	200	700	1100	188	206800	0.62	128.2	10	250	200	890	1290	190	245100	0.62	152.0	10	200	200	890	1290	224	288960	0.62	179.2	
13		10	240	200	750	1150	188	216200	0.62	134.0	10	250	200	920	1320	190	250800	0.62	155.5	10	200	200	920	1320	224	295680	0.62	183.3	
14		10	250	200	22400	22800	14	319200	0.62	197.9	10	250	200	22400	22800	22	501600	0.62	311.0	10	250	200	22400	22800	22	501600	0.62	311.0	
15		10	250	200	22400	22800	14	319200	0.62	197.9	10	250	160	22400	22720	14	318080	0.62	197.2	10	250	175	22400	22750	22	500500	0.62	310.3	
16		10	250	200	22400	22800	28	638400	0.62	395.8	10	250	160	22400	22720	28	636160	0.62	394.4	10	250	160	22400	22720	44	999680	0.62	619.8	
17		10	250	200	22400	22800	28	638400	0.62	395.8	10	220	210	22400	22820	44	1004080	0.62	622.5	10	240	210	22400	22820	46	1049720	0.62	650.8	
18		10	250	200	22400	22800	12	273600	0.62	169.6	10	220	210	22400	22820	12	273840	0.62	169.8	10	250	210	22400	22820	12	273840	0.62	169.8	
19		10	-	160	22400	22720	20	454400	0.62	281.7	10	-	160	22400	22720	20	454400	0.62	281.7	10	-	160	22400	22720	20	454400	0.62	281.7	
20		Bar not used									10	-	160	22400	22720	2	45440	0.62	28.2	10	-	160	22400	22720	2	45440	0.62	28.2	
21		10	150	150	470	620	64	39680	0.62	24.6	10	150	150	600	750	92	69000	0.62	42.8	10	150	150	470	620	92	57040	0.62	35.4	
22		10	-	160	4650	4970	16	79520	0.62	49.3	10	-	160	6750	7070	16	113120	0.62	70.1	10	-	160	4650	4970	16	79520	0.62	49.3	
23		10	150	1100	1550	1700	64	108800	0.62	67.5	10	150	1100	1550	1700	92	156400	0.62	97.0	10	150	1100	1550	1700	100	170000	0.62	105.4	
24		12	-	200	4650	5050	20	101000	0.89	89.9	12	-	200	6750	7150	20	143000	0.89	127.3	12	-	200	6850	7250	20	145000	0.89	129.1	
									5943.9										8773.6										10438.9

NOTES:

1. Joint or lapping of bars shall be suitably Staggered as per clause 304.6 of IRC: 21-2000.
2. This Drawing shall be read in conjunction with other relevant Drawings.
3. Quantity of steel includes 5% extra for wastage and laps.
4. Quantity of steel are for per metre width.

Government of Nepal Ministry of Physical Infrastructure & Transport Department of Roads			
STANDARD DRAWINGS FOR ROAD ELEMENTS			
BOX CULVERT DOUBLE CELL WITH 3M EARTH CUSHION			
BAR BENDING SCHEDULE			
	Recommended by	Approved by	
Signature			SHEET. NO. 44
Designation	Deputy Director General	Director General	

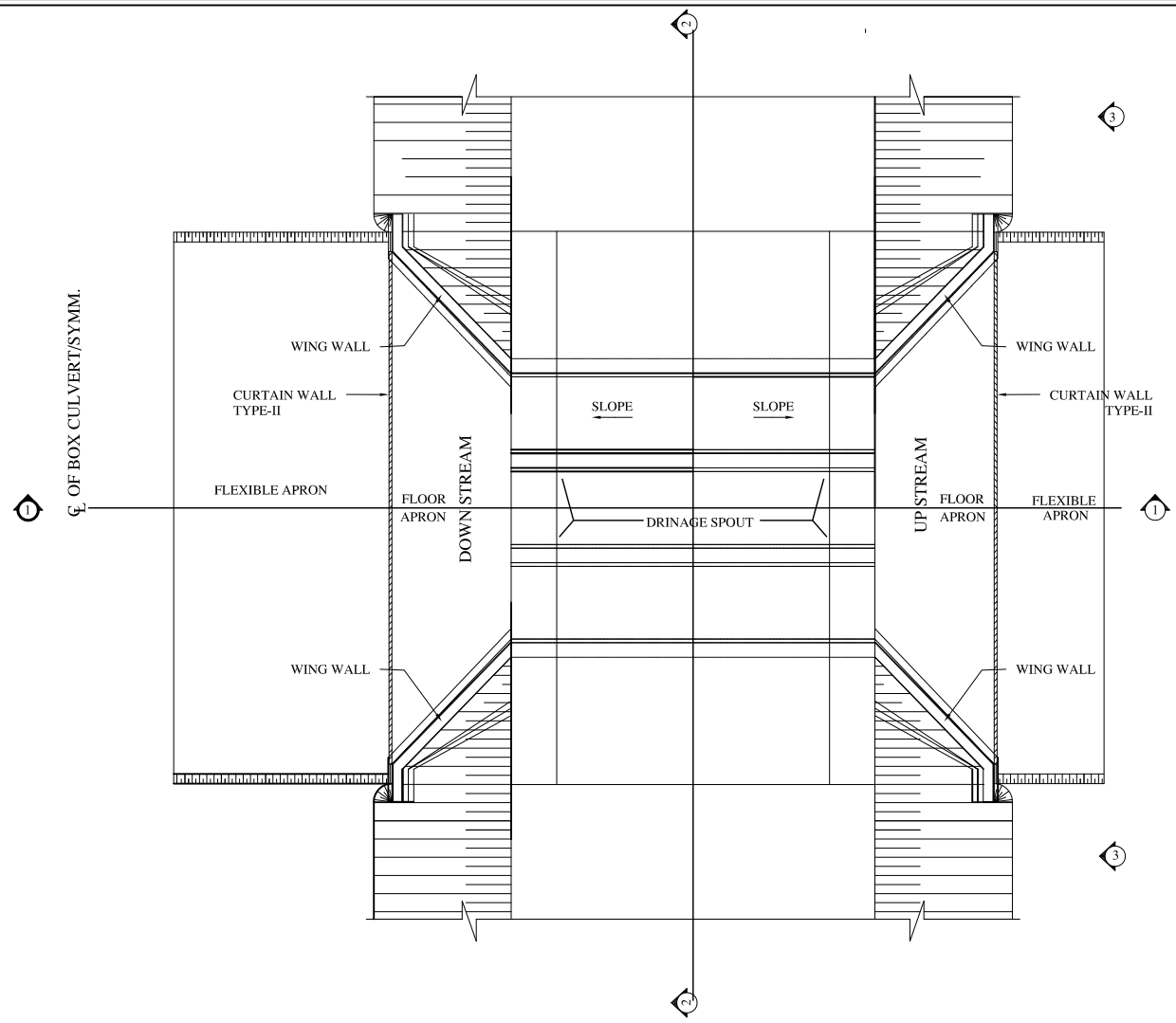

PLAN AT ROAD LEVEL

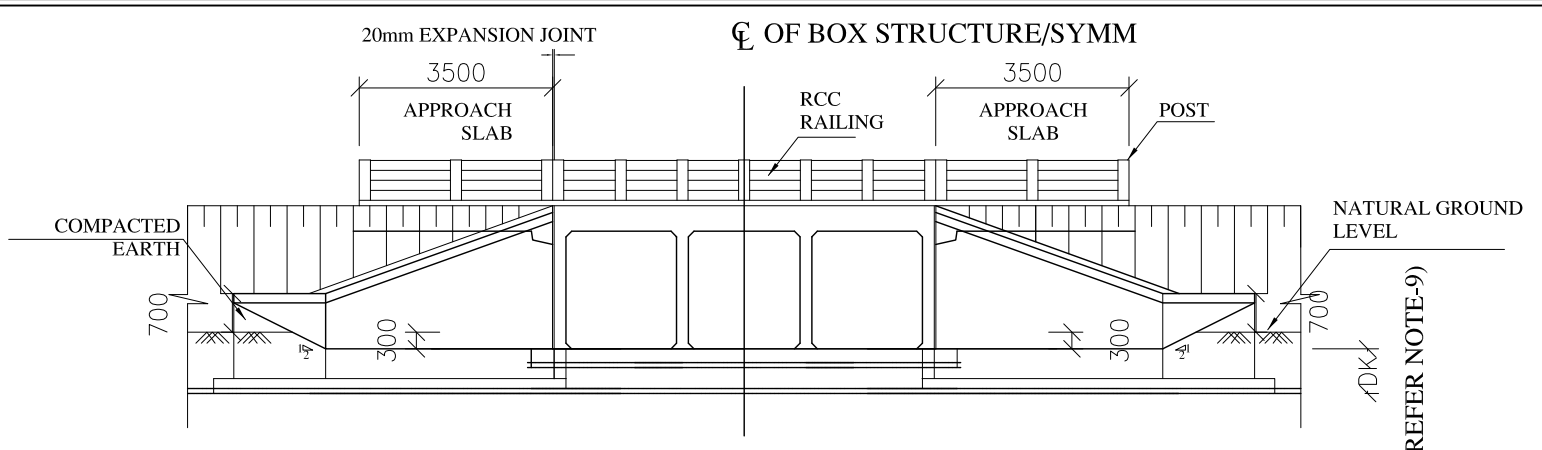

VIEW 3-3
(Scale 1:200)

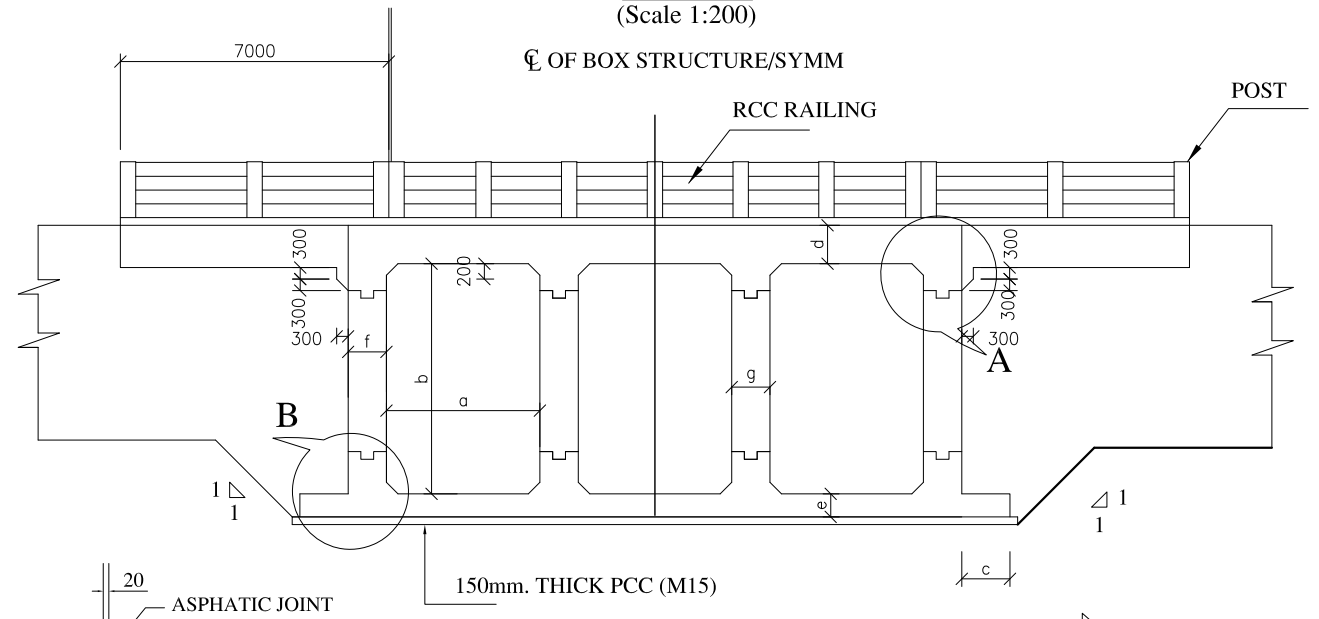

SECTION 2-2

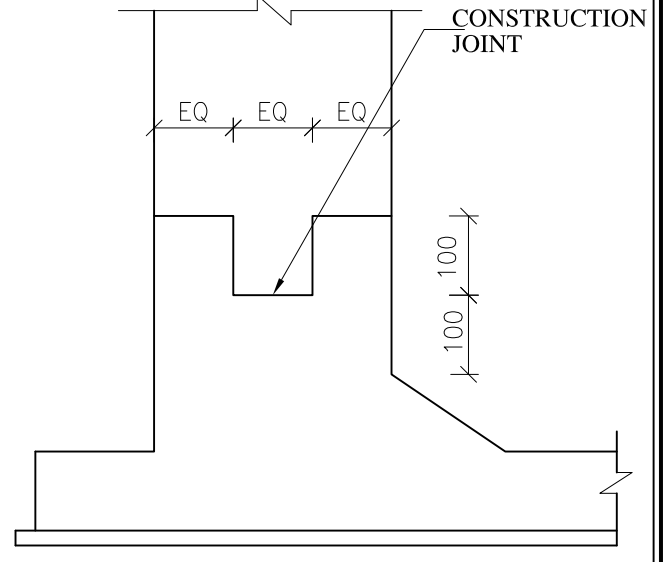

DETAIL B

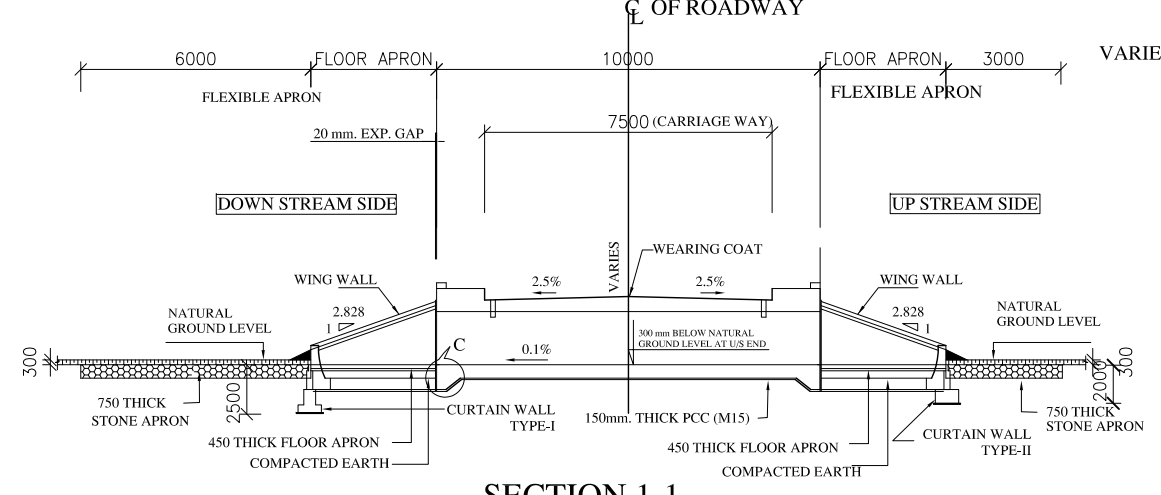

SECTION 1-1

TABLE SHOWING SALIENT DIMENSIONS OF TRIPLE CELL BOX CULVERT

Box Cell Designation	a (mm)	b (mm)	c (mm)	d (mm)	e (mm)	f (mm)	g (mm)	h (mm)	Design base Pressure t/m ²
2 m x 2 m	2000	2000	300	370	370	370	300	NA	7.50
3 m x 3 m	3000	3000	300	450	500	470	400	NA	7.1

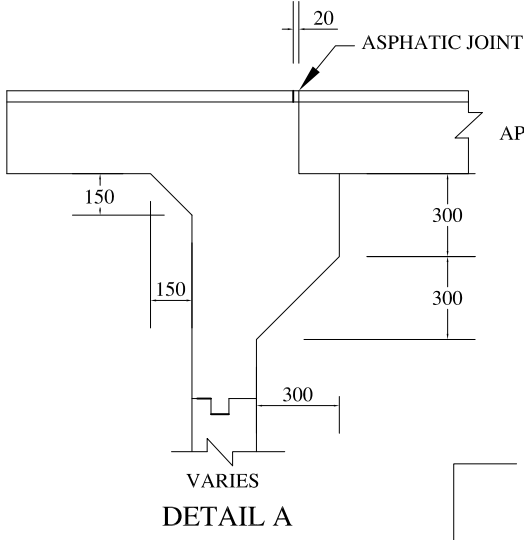

DETAIL A

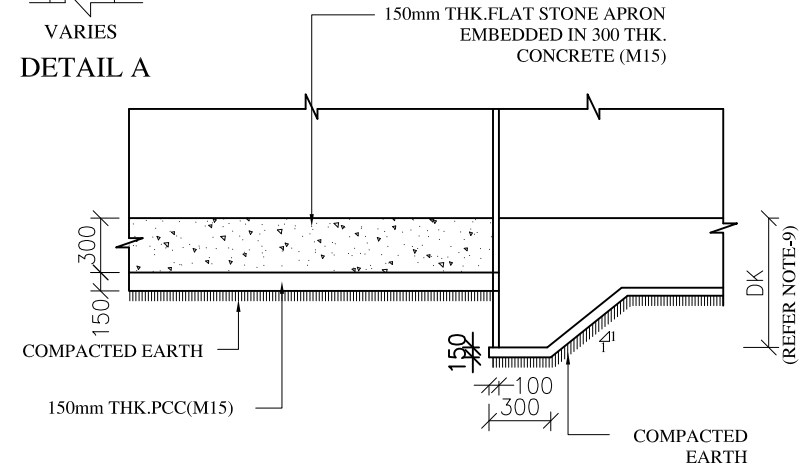

DETAIL -C
(Scale 1:200)

Government of Nepal
Ministry of Physical Infrastructure & Transport
Department of Roads

STANDARD DRAWINGS FOR ROAD ELEMENTS

BOX CULVERT TRIPPLE CELL WITHOUT EARTH CUSJOPN

GENERAL DETAILS

Recommended by	Approved by	SHEET. NO. 45
Signature: Arjun Jung Thapa	Signature: Devendra Karki	
Designation: Deputy Director General	Designation: Director General	

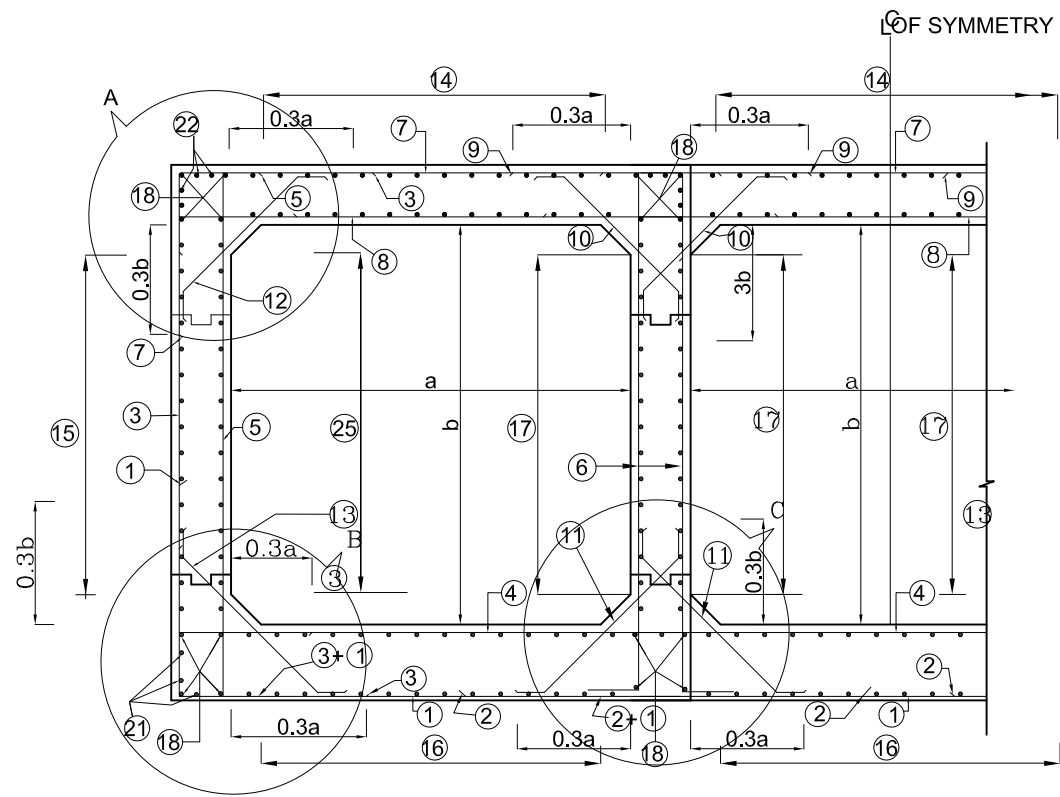

REINFORCEMENT DETAILS OF TRIPPLE CELL BOX
CULVERT
(Scale 1:100)

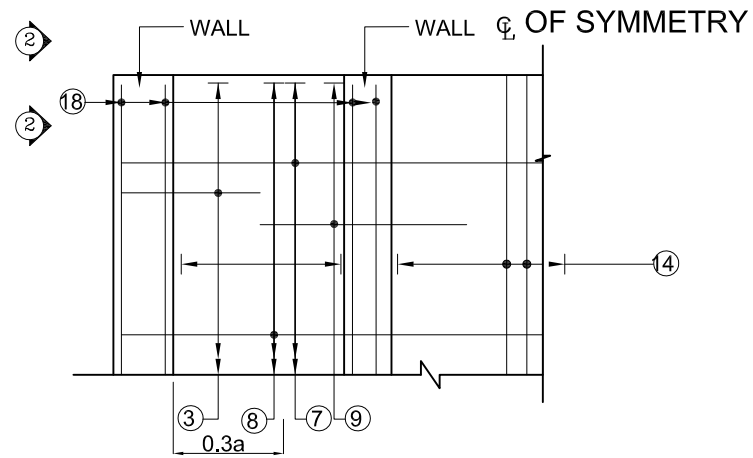

TOP SLAB R/F PLAN
(Scale 1:100)

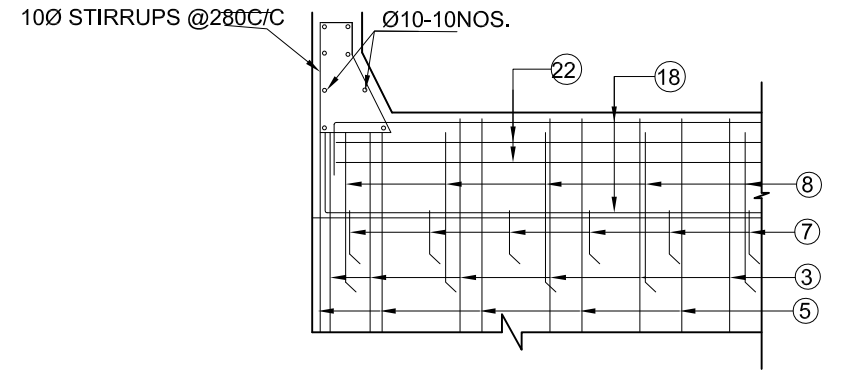

VIEW 2-2
(Scale 1:100)

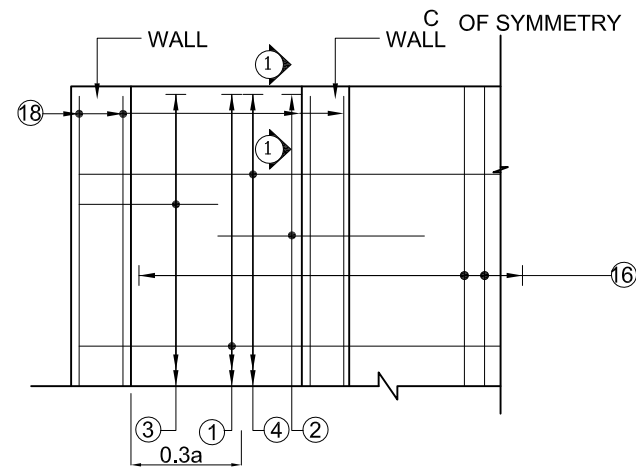

BOTTOM SLAB R/F PLAN
(Scale 1:100)

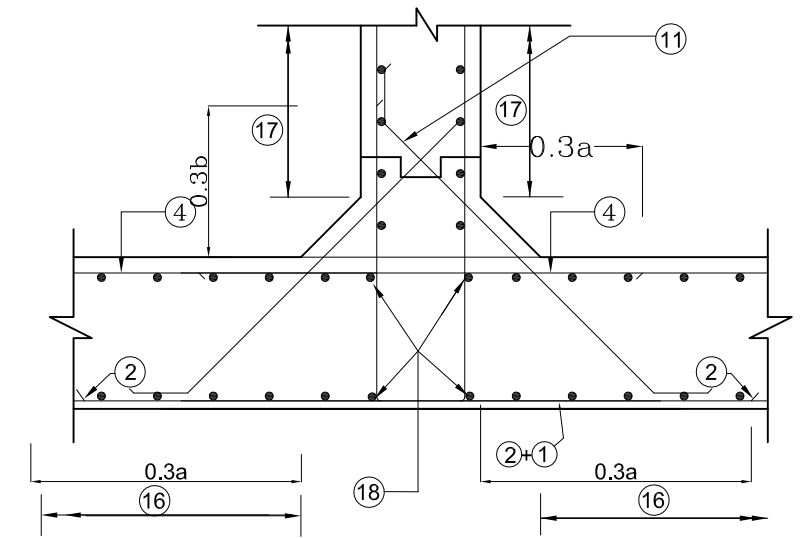

DETAIL - C
(Scale 1:100)

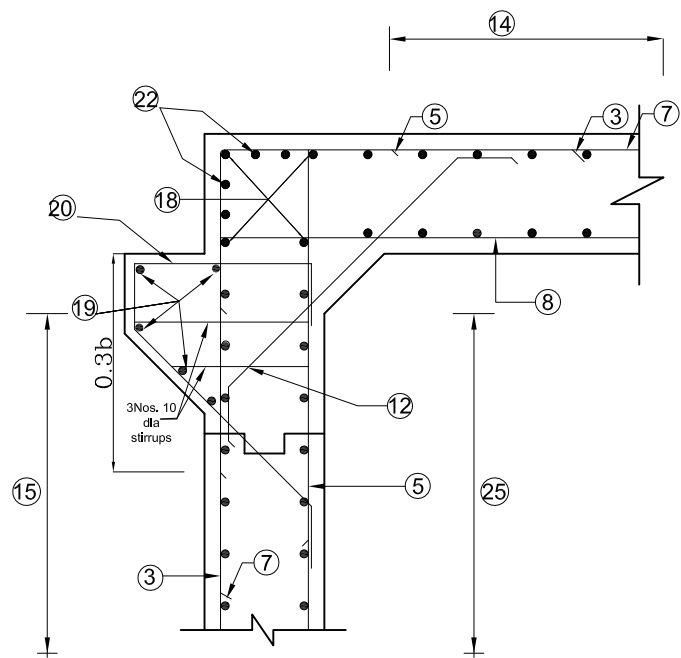

DETAIL - A
(Scale 1:100)

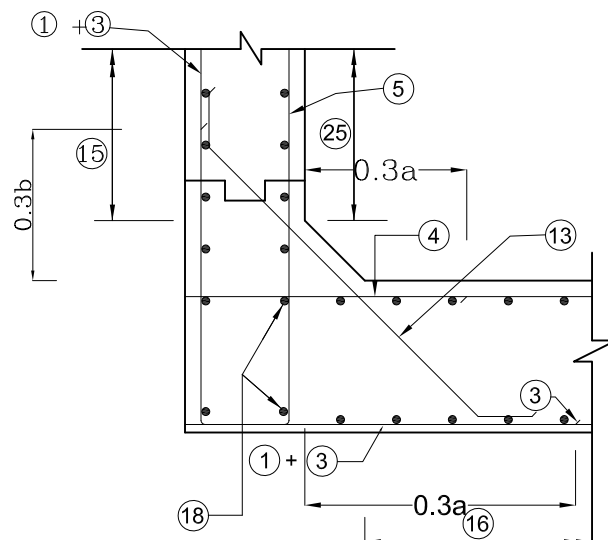

DETAIL - B
(Scale 1:100)

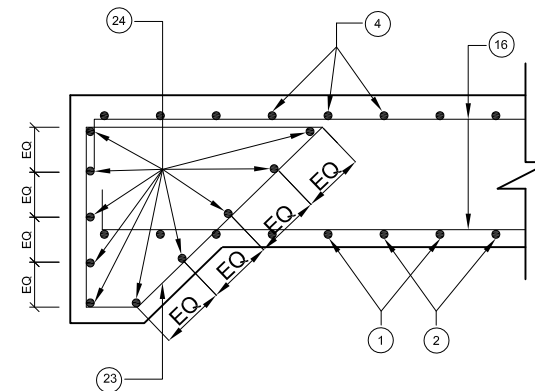

SECTION 1-1
(Scale 1:100)

LEGEND:
 ——— : TOP FACE BARS / OUTER FACE BARS
 - - - : BOTTOM FACE BARS / INNER FACE BARS

Government of Nepal Ministry of Physical Infrastructure & Transport Department of Roads			
STANDARD DRAWINGS FOR ROAD ELEMENTS			
TRIPPLE CELL CULVERT WITHOUT EARTH CUSHION			
REINFORCEMENT DETAIL			
Recommended by	Approved by	SHEET. NO.	
Signature <i>Arjun Jung Thapa</i>	Signature <i>Devendra Karki</i>	46	
Designation Deputy Director General	Designation Director General		

BAR MARK	BOX-CELL DESIGNATION Nc/ab/Ec SHAPE OF BARS (NOT TO SCALE)	Triple Cell Box Culvert 2m x2m without earth cushion									Triple Cell Box Culvert 3m x3m without earth cushion								
		BAR DIA. in mm.	SPACING in mm.	M1 in mm.	M2 in mm.	LENGTH in mm.	NO. OF BARS	TOTAL LENGTH in mm.	Wt/m, kg	Weight, kg	BAR DIA.	SPACING	M1 in mm.	M2 in mm.	LENGTH in mm.	NO. OF BARS	TOTAL LENGTH in mm.	Wt/m, kg	Weight, kg
1	M1 M2 M1	16	250	920	7240	9080	40	363200	1.58	573.9	16	200	1350	10640	13340	50	667000	1.58	1053.9
2	M1	12	250	1500	0	1500	80	120000	0.89	106.8	12	200	2200	0	2200	100	220000	0.89	195.8
3	M2 M1 M1	16	250	920	2640	4480	80	358400	1.58	566.3	16	200	1320	3850	6490	102	661980	1.58	1045.9
4	M1 M2 M1	16	250	200	7240	7640	40	305600	1.58	482.8	20	200	200	10640	11040	50	552000	2.47	1363.4
5	M2 M1 M1	16	250	260	2640	3160	80	252800	1.58	399.4	16	200	260	3850	4370	102	445740	1.58	704.3
6	M2 M1 M1	20	250	320	2640	3280	160	524800	2.47	1296.3	20	200	320	3850	4490	204	915960	2.47	2262.4
7	M1 M2 M1	16	250	920	7240	9080	40	363200	1.58	573.9	16	200	1300	10640	13240	50	662000	1.58	1046.0
8	M1 M2 M1	20	250	320	7240	7880	40	315200	2.47	778.5	20	200	320	10640	11280	50	564000	2.47	1393.1
9	M1	16	250	1500	0	1500	80	120000	1.58	189.6	16	200	2200	0	2200	102	224400	1.58	354.6
10	M1 M2 M1	10	250	200	920	1320	160	211200	0.62	130.9	10	200	200	1170	1570	204	320280	0.62	198.6
11	M1 M2 M1	10	250	200	920	1320	160	211200	0.62	130.9	10	200	200	1240	1640	204	334560	0.62	207.4
12	M1 M2 M1	10	250	200	1020	1420	80	113600	0.62	70.4	10	200	200	1270	1670	102	170340	0.62	105.6
13	M1 M2 M1	10	250	200	1020	1420	80	113600	0.62	70.4	10	200	200	1340	1740	102	177480	0.62	110.0
14	M1 M2 M1	10	250	230	9900	10360	40	414400	0.62	256.9	10	200	270	9900	10440	82	856080	0.62	530.8
15	M1 M2 M1	12	250	190	9900	10280	14	143920	0.89	128.1	12	200	230	9900	10360	28	290080	0.89	258.2
16	M1 M2 M1	12	250	190	9900	10280	42	431760	0.89	384.3	12	200	250	9900	10400	82	852800	0.89	759.0
17	M1 M2 M1	12	250	190	9900	10280	30	308400	0.89	274.5	12	200	190	9900	10280	56	575680	0.89	512.4
18	M1 M2 M1	12	-	200	9900	10300	32	329600	0.89	293.3	12	-	200	9900	10300	32	329600	0.89	293.3
19	M1	12	-	9900	0	9900	10	99000	0.89	88.1	12	-	9900	0	9900	10	99000	0.89	88.1
20	M1 M2	12	250	1000	1260	2260	80	180800	0.89	160.9	12	200	1000	1300	2300	102	234600	0.89	208.8
21	M1 M2 M1	10	-	160	9900	10220	4	40880	0.62	25.3	10	-	160	9900	10220	4	40880	0.62	25.3
22	M1 M2 M1	10	-	160	9900	10220	4	40880	0.62	25.3	10	-	160	9900	10220	4	40880	0.62	25.3
23	M1 M2 M1	12	150	1100	1550	4150	100	415000	0.89	369.4	12	200	1100	1550	4150	102	423300	0.89	376.7
24	M1 M2 M1	12	-	190	7240	7620	20	152400	0.89	135.6	12	-	190	10640	11020	20	220400	0.89	196.2
25	M1 M2 M1	10	250	180	9900	10260	16	164160	0.62	101.8	10	250	230	9900	10360	24	248640	0.62	154.2
										7613.8									13469.2

- NOTES:
1. Joint or lapping of bars shall be suitably Staggered as per clause 304.6 of IRC: 21-2000.
 2. This Drawing shall be read in conjunction with other relevant Drawings.
 3. Quantity of steel includes 5% extra for wastage and laps.
 4. Quantity of steel are for per metre width.

Government of Nepal
Ministry of Physical Infrastructure & Transport
Department of Roads

STANDARD DRAWINGS FOR ROAD ELEMENTS
BOX CULVERT TRIPLE CELL WITHOUT EARTH CUSHION

BAR BENDING SCHEDULE

	Recommended by	Approved by	SHEET. NO.
Signature			47
	Arjun Jung Thapa	Devendra Karki	
Designation	Deputy Director General	Director General	

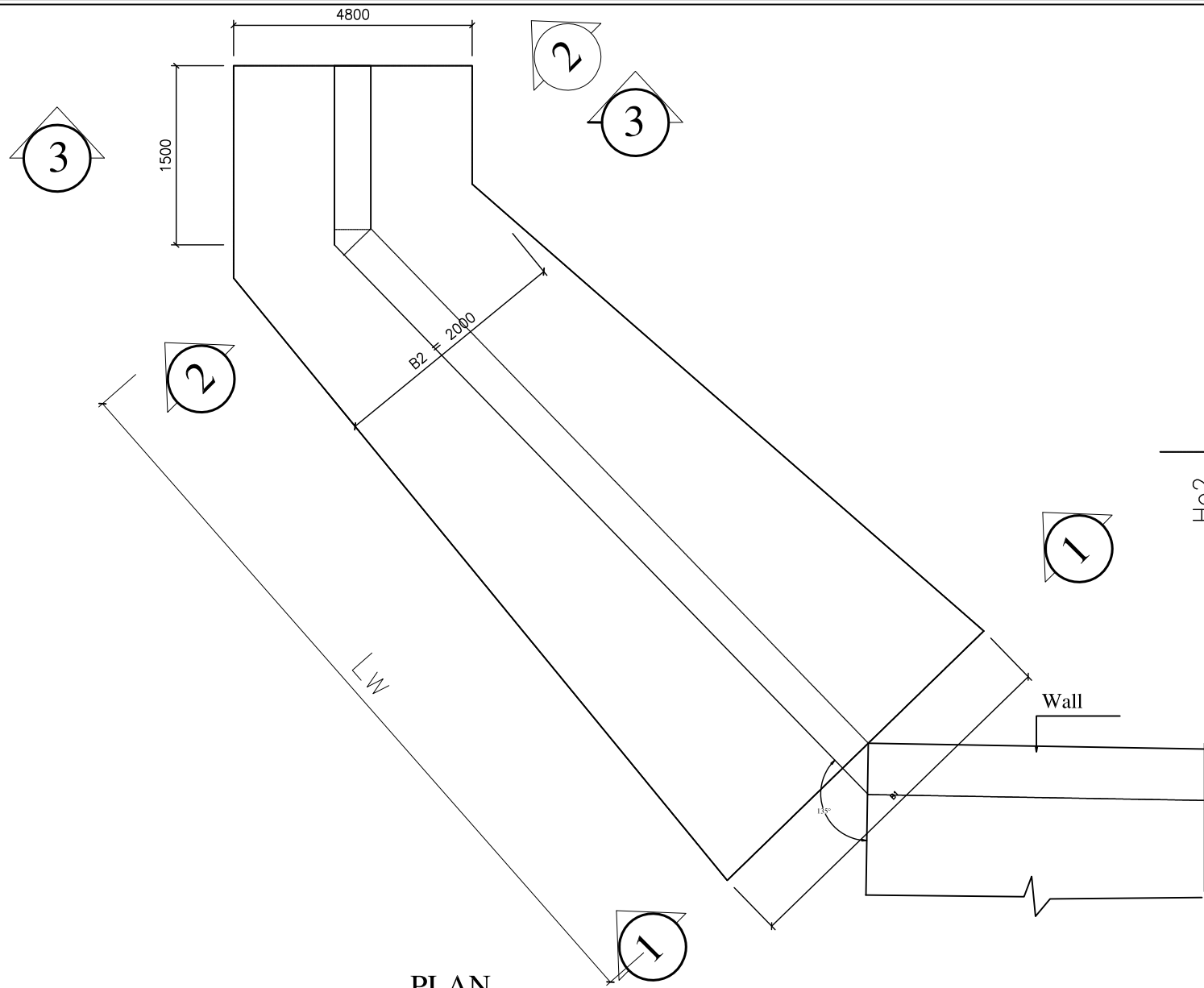

PLAN

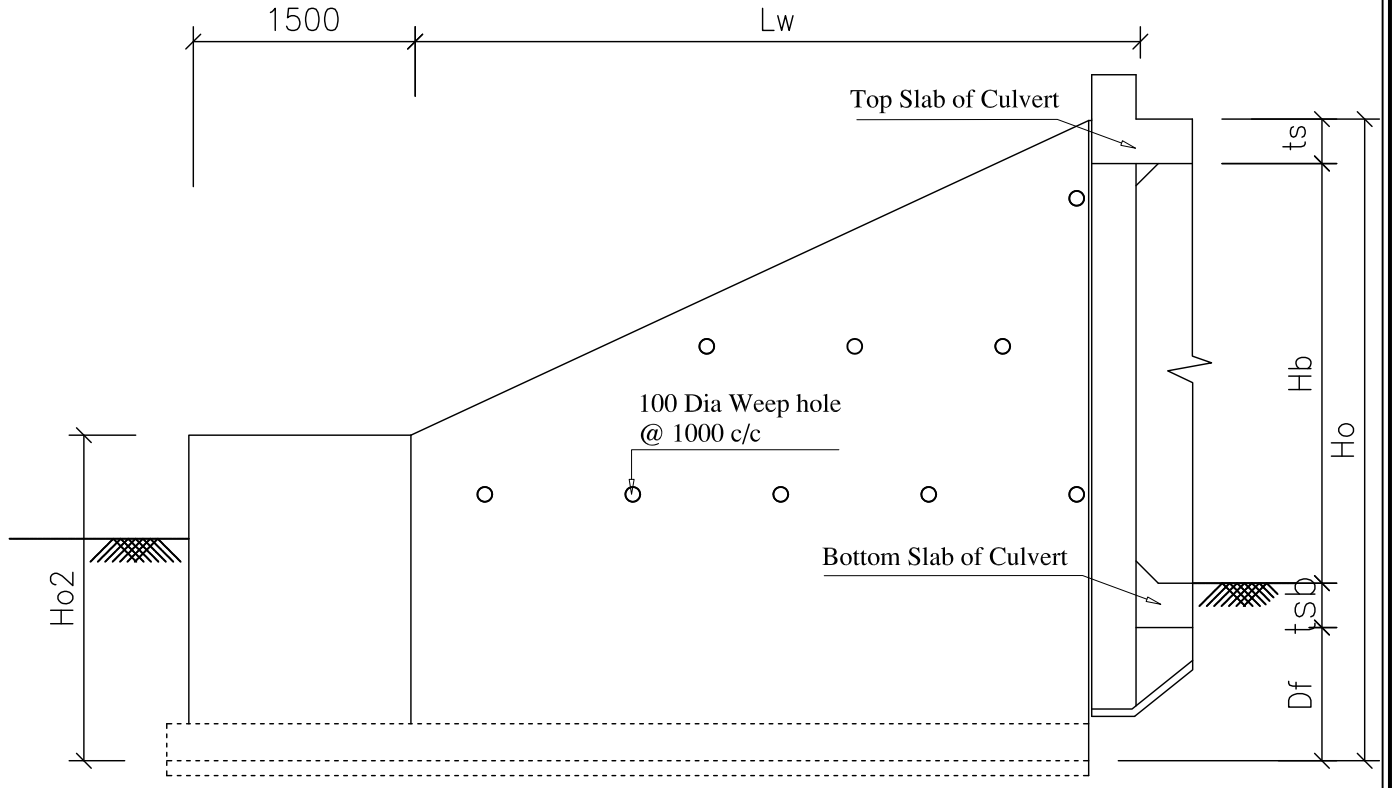

ELEVATION

S.No.	Height of Opening, Hb (mm)	Depth of Foundation, Df (mm)	Max. ht. Ho (mm)	Length of wing wall, Lw (mm)	Section 1 -1				Section 2 -2 and 3 -3			
					T (mm)	T1 (mm)	B (mm)	D1 (mm)	T (mm)	T1 (mm)	B (mm)	D1 (mm)
1	2000	1500	3450	3535	200	450	2450	500	200	400	2000	500
2	3000	1500	4570	6702	200	500	2600	500	200	400	2000	500
3	4000	1500	5670	9813	200	550	3000	500	200	400	2000	500

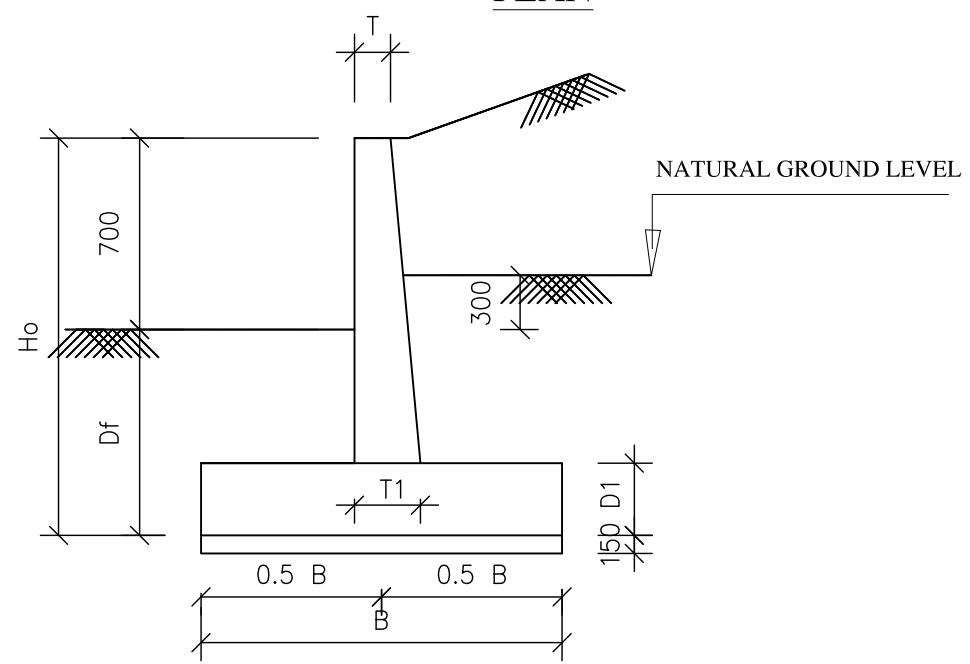

SECTION 2-2 and 3-3

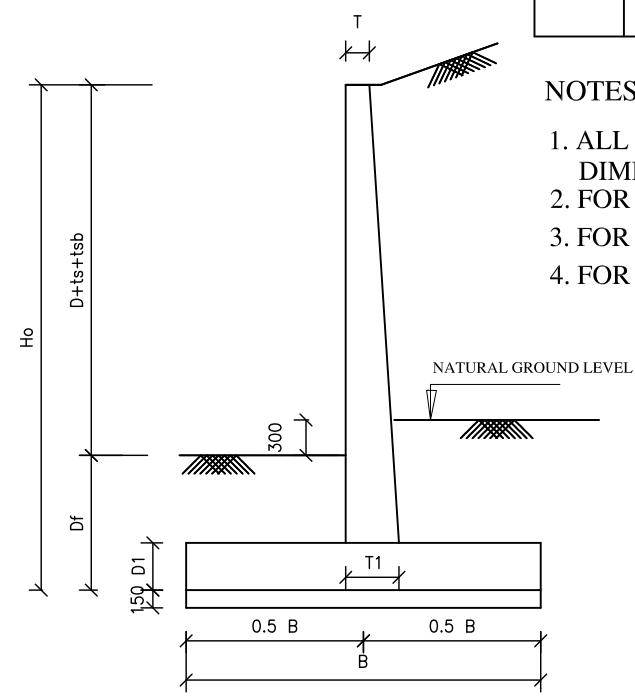

SECTION 1-1

NOTES:

1. ALL DIMENSIONS ARE IN MILLIMETERS UNLESS OTHERWISE MENTIONED. ONLY WRITTEN DIMENSIONS ARE TO BE FOLLOWED.
2. FOR GENERAL NOTES AND REFERENCE DRAWINGS REFER DRG NO.
3. FOR REINFORCEMENT DETAIL REFER DRG. NO.
4. FOR DETAILS OF WING WALL REFER \DRG. NO.

Government of Nepal Ministry of Physical Infrastructure & Transport Department of Roads			
STANDARD DRAWINGS FOR ROAD ELEMENTS			
BOX CULVERT WING WALL			
GENERAL DETAILS			
Recommended by	Approved by		SHEET. NO. 48
Signature	Signature		
Arjun Jung Thapa	Devendra Karki		
Designation	Deputy Director General	Director General	

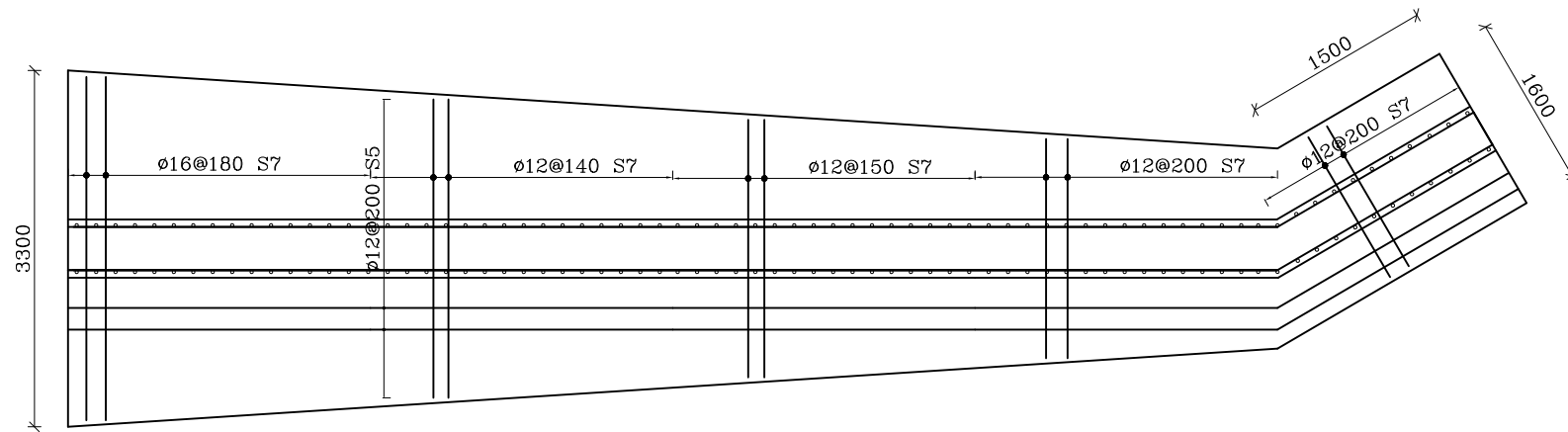
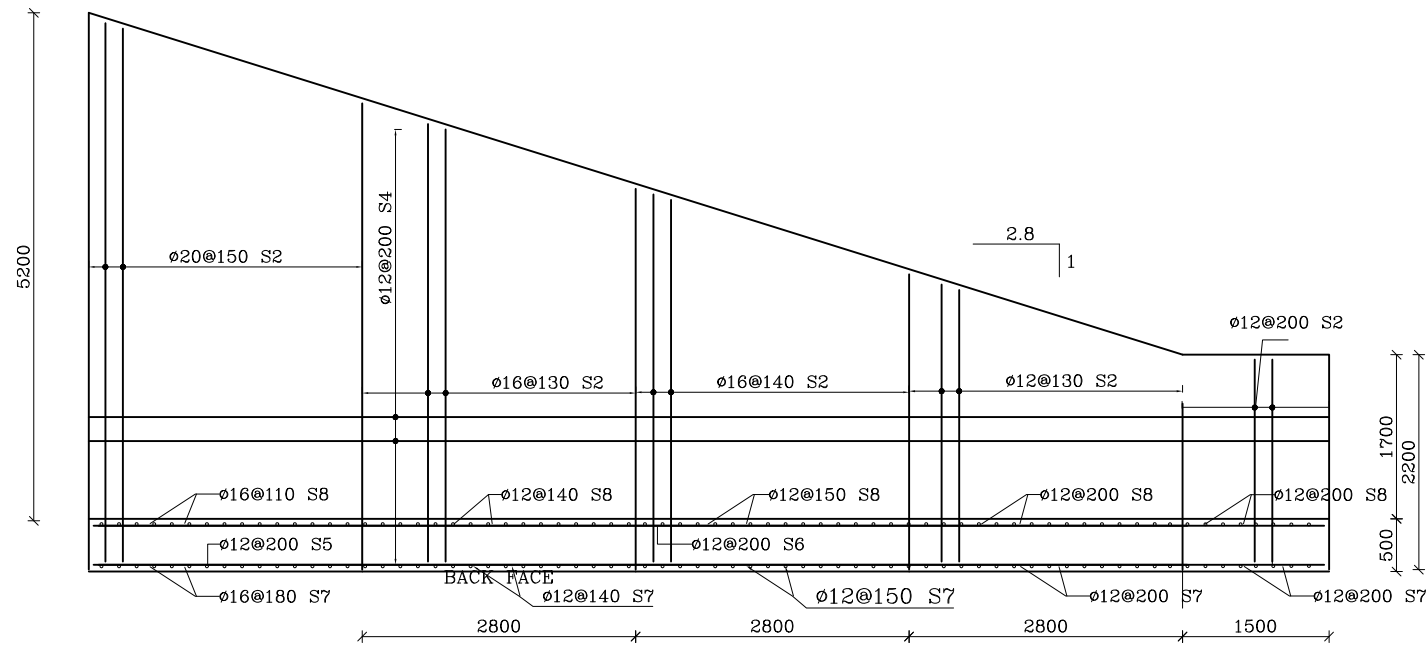

PLAN (BOTTOM)

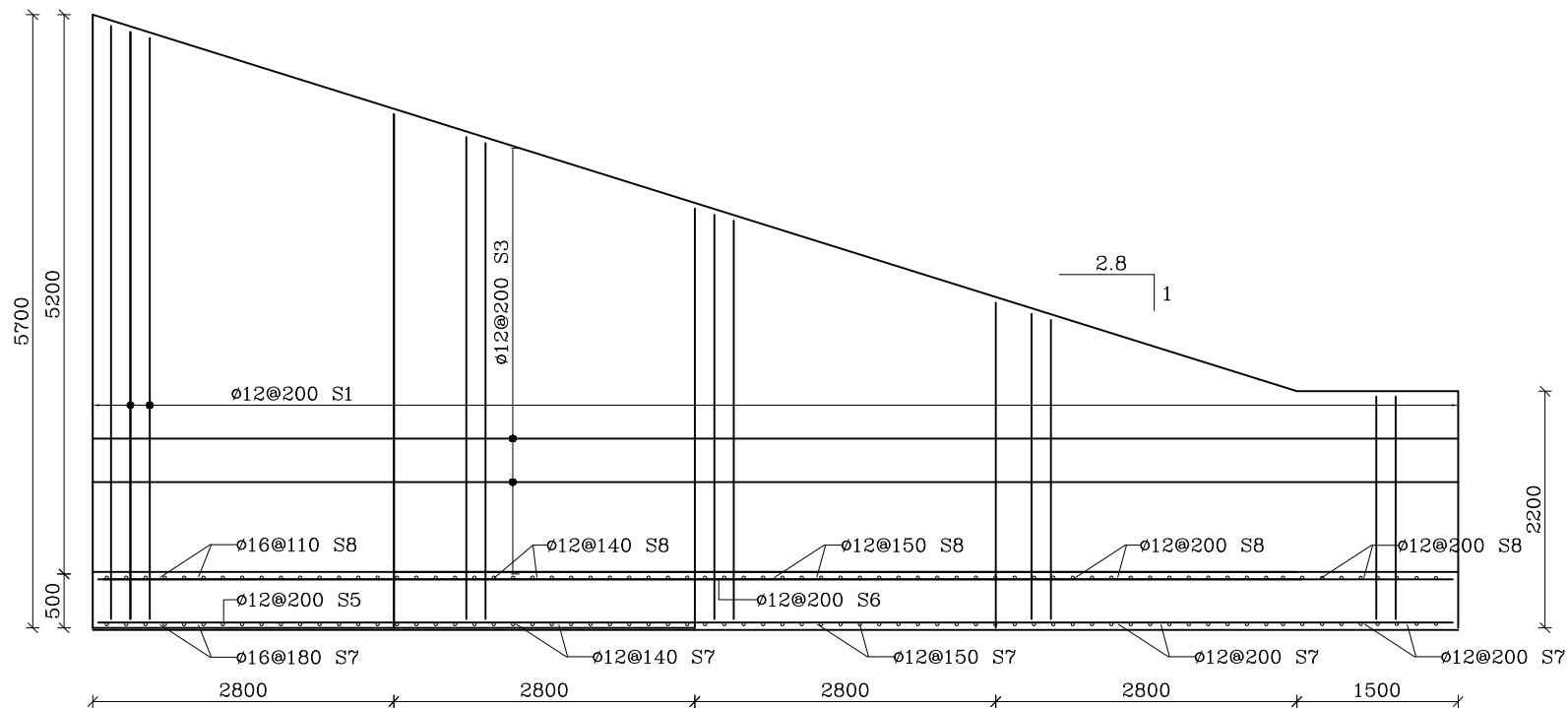

FRONT FACE

BAR MARK	SHAPE OF BAR (NOT TO SCALE)	Depth of Opening 4 m	Depth of Opening 4 m						Depth of Opening 3 m						Depth of Opening 2 m																	
			BAR DIA in mm	SPACING in mm	NO. OF BARS	LENGTH in mm	Wt. in kg	Wt. in kg	BAR DIA in mm	SPACING in mm	NO. OF BARS	LENGTH in mm	Wt. in kg	Wt. in kg	BAR DIA in mm	SPACING in mm	NO. OF BARS	LENGTH in mm	Wt. in kg	Wt. in kg												
1	M2	M1	12	200	300	2100	2400	8	2.4	0.89	17.09	12	200	300	2100	2400	8	2.4	0.89	17.09	12	200	300	2100	2400	8	2.4	0.89	17.09			
	M2		M1	12	200	300	AV 3800	4100	49	4.1	0.89	178.80	12	200	300	AV 2300	2835	26	2.63	0.89	60.86	12	200	300	AV 2700	3000	18	3.0	0.89	48.06		
	M2	M1	12	200	300	2100	2400	8	2.4	0.89	17.09	12	200	300	2100	2400	8	2.4	0.89	17.09	12	200	300	2100	2400	8	2.4	0.89	17.09			
	M2		M1	12	130	300	AV 2350	2650	7	2.65	0.89	16.51	12	200	300	AV 2300	2800	7	2.60	0.89	16.2	12	200	300	AV 2300	2800	7	2.60	0.89	16.2		
2	M2	M1	16	140	300	AV 3100	3400	20	3.4	1.58	107.40	12	130	300	AV 2970	3270	21	3.27	0.89	61.1	12	130	300	AV 2900	3200	16	3.20	0.89	45.6			
	M2		M1	16	130	300	AV 4100	4400	22	4.4	1.58	152.90	16	130	300	AV 3990	4290	20	4.29	1.58	135.6	NA	NA	NA	NA	NA	NA	NA	NA	NA	NA	
	M2	M1	20	150	300	AV 5100	5400	19	5.4	2.47	253.40	NA	NA	NA	NA	NA	NA	NA	NA	NA	NA	NA	NA	NA	NA	NA	NA	NA	NA	NA		
	M1		M2	12	200	9700	1400	11100	2	11.1	0.89	177.80	12	200	6600	1400	8000	2	8.0	0.89	128.2	12	200	3500	1400	4900	2	4.90	0.89	78.50		
3 and 4	M1	M2	12	200	AV 5100	0	5100	2	5.1	0.89	157.00	12	200	AV 3550	0	3550	2	3.55	0.89	82.2	12	200	AV 1950	0	1.95	2	1.95	0.89	20.29			
	M1		M2	12	170	9700	1400	11100	2	11.1	0.89	256.80	12	180	6000	1400	8000	2	8.0	0.89	156.6	12	180	3400	1400	4800	2	4.80	0.89	93.98		
5 and 6	M1	M2	12	170	AV 5100	0	5100	2	5.1	0.89	72.60	12	180	AV 3300	0	3300	2	3.30	0.89	23.5	12	180	AV 1700	0	1.70	2	1.70	0.89	12.10			
	M1		M2	12	200	100	1800	2000	7	2.0	0.89	12.50	12	200	100	1800	2000	7	2.0	0.89	12.5	12	200	100	1800	2000	7	2.0	0.89	12.5		
	M1	M2	12	200	100	AV 2025	2225	14	2.225	0.89	27.60	12	200	100	AV 2025	2225	5	2.25	0.89	10.0	12	200	100	AV 2100	2300	14	2.30	0.89	28.6			
	M1		M2	12	150	100	AV 2330	2530	19	2.53	0.89	42.80	12	150	100	AV 2275	2475	7	2.48	0.89	15.5	12	150	100	AV 2300	2500	4	2.50	0.89	8.9		
7	M1	M2	12	140	100	AV 2620	2820	20	2.82	0.89	50.20	12	140	100	AV 2450	2650	8	2.65	0.89	18.9	NA	NA	NA	NA	NA	NA	NA	NA	NA	NA		
	M1		M2	16	180	100	AV 2830	3030	8	3.03	1.58	38.30	NA	NA	NA	NA	NA	NA	NA	NA	NA	NA	NA	NA	NA	NA	NA	NA				
	M1	M2	12	200	100	1800	2000	7	2.0	0.89	12.50	12	200	100	1800	2000	7	2.0	0.89	12.5	12	200	100	1800	2000	7	2.0	0.89	12.5			
	M1		M2	12	200	100	AV 2025	2225	14	2.25	0.89	27.60	12	200	100	AV 2025	2225	5	2.25	0.89	10.0	12	200	100	AV 2100	2300	14	2.30	0.89	28.6		
8	M1	M2	12	150	100	AV 2330	2530	19	2.53	0.89	42.80	12	150	100	AV 2275	2475	7	2.48	0.89	15.5	12	150	100	AV 2300	2500	4	2.50	0.89	8.9			
	M1		M2	12	140	100	AV 2620	2820	20	2.82	0.89	50.20	12	140	100	AV 2450	2650	8	2.65	0.89	18.9	NA	NA	NA	NA	NA	NA	NA	NA	NA		
	M1	M2	16	180	100	AV 2820	3030	8	3.03	1.58	38.30	NA	NA	NA	NA	NA	NA	NA	NA	NA	NA	NA	NA	NA	NA	NA	NA	NA	NA			
	M1		M2	12	200	100	1800	2000	7	2.0	0.89	12.50	12	200	100	1800	2000	7	2.0	0.89	12.5	12	200	100	1800	2000	7	2.0	0.89	12.5		
Total			1750.2																		812.24						448.93					

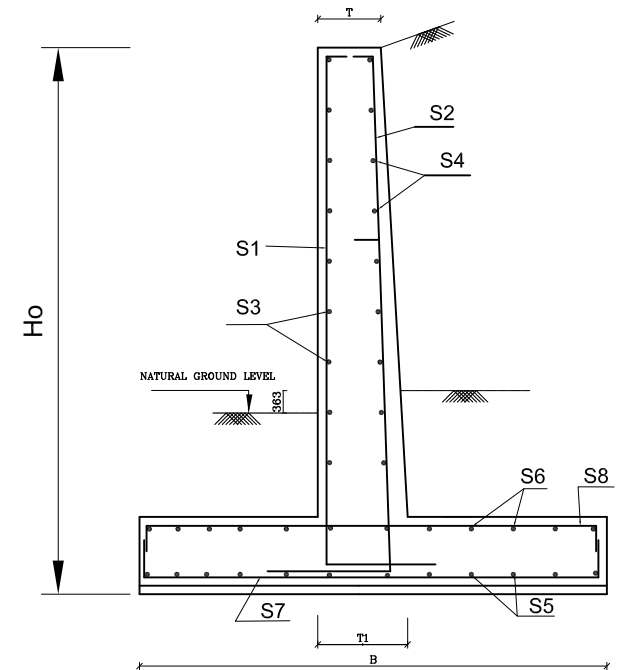

ARRANGEMENT OF REINFORCEMENTS

Government of Nepal
Ministry of Physical Infrastructure & Transport
Department of Roads

STANDARD DRAWINGS FOR ROAD ELEMENTS

BOX CULVERT

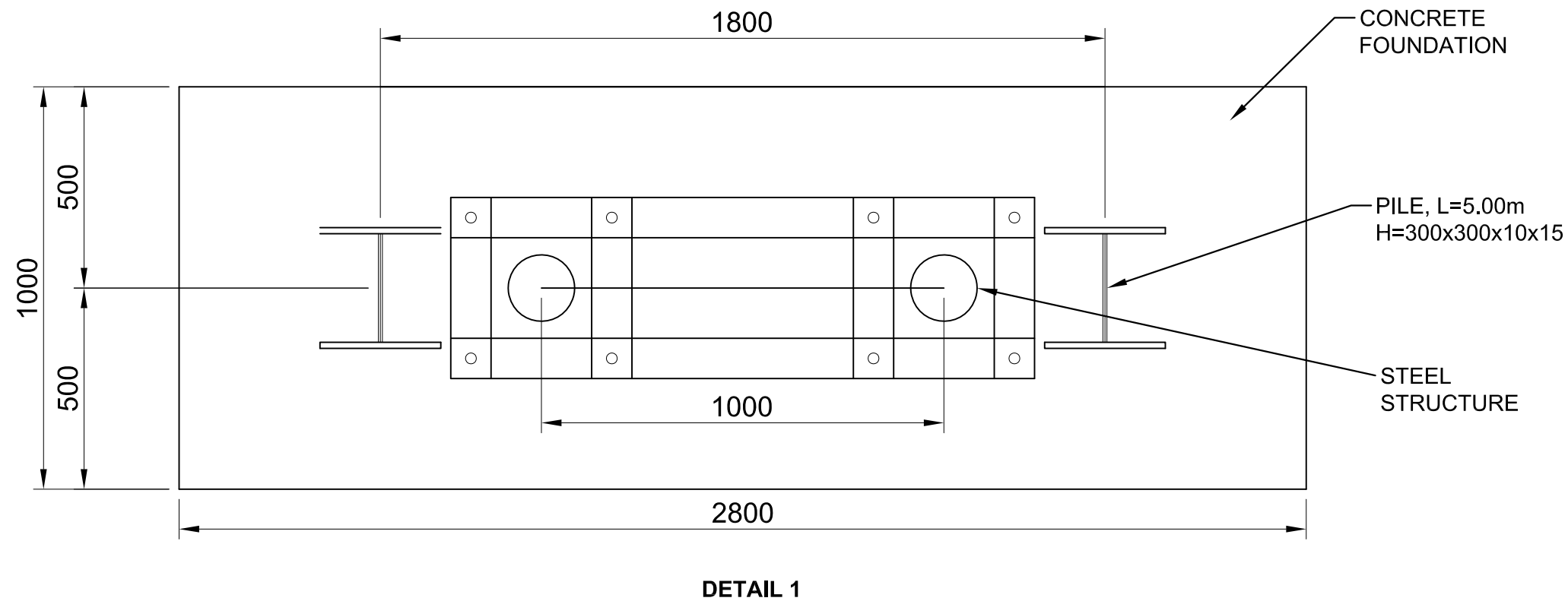
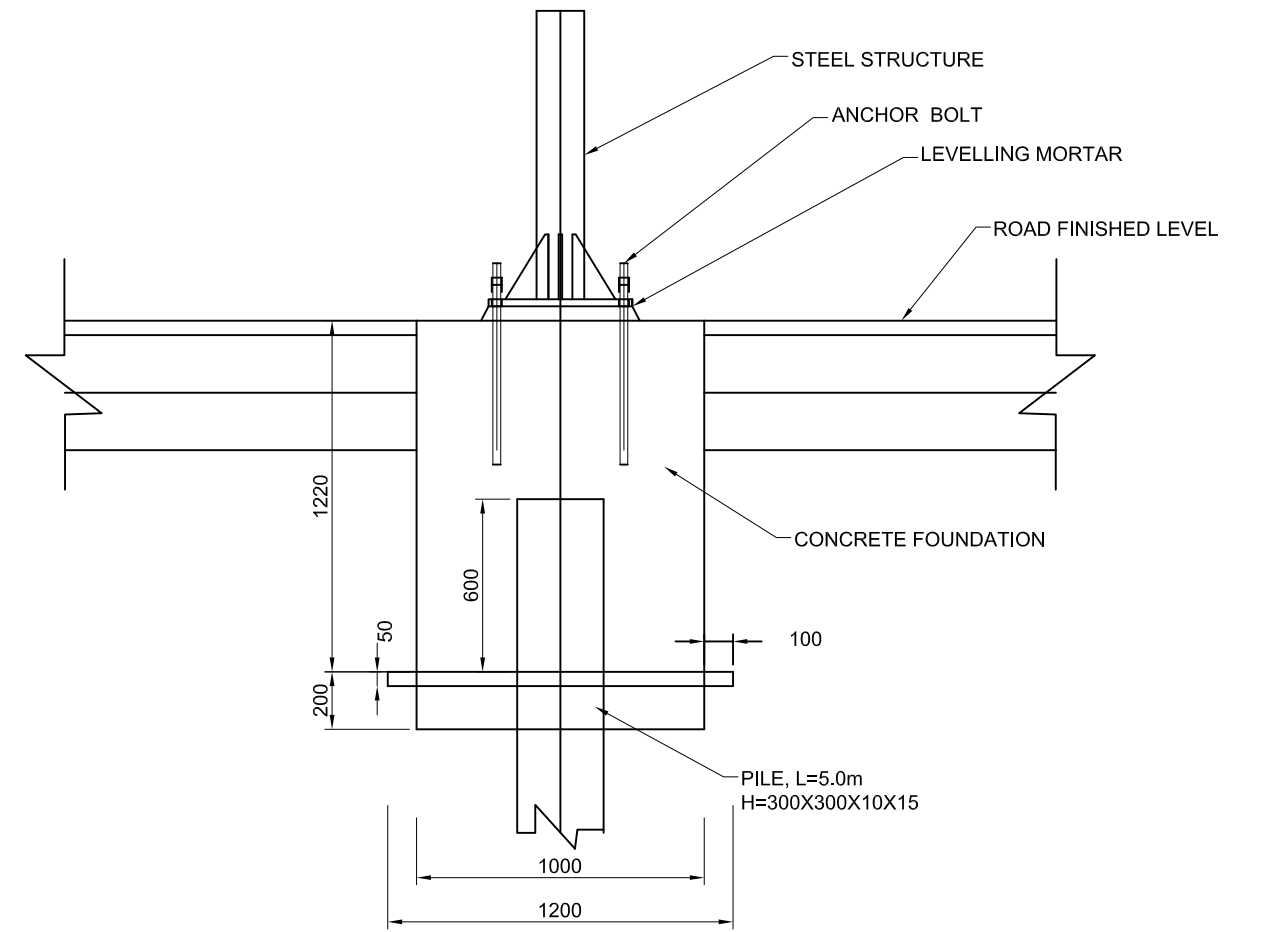
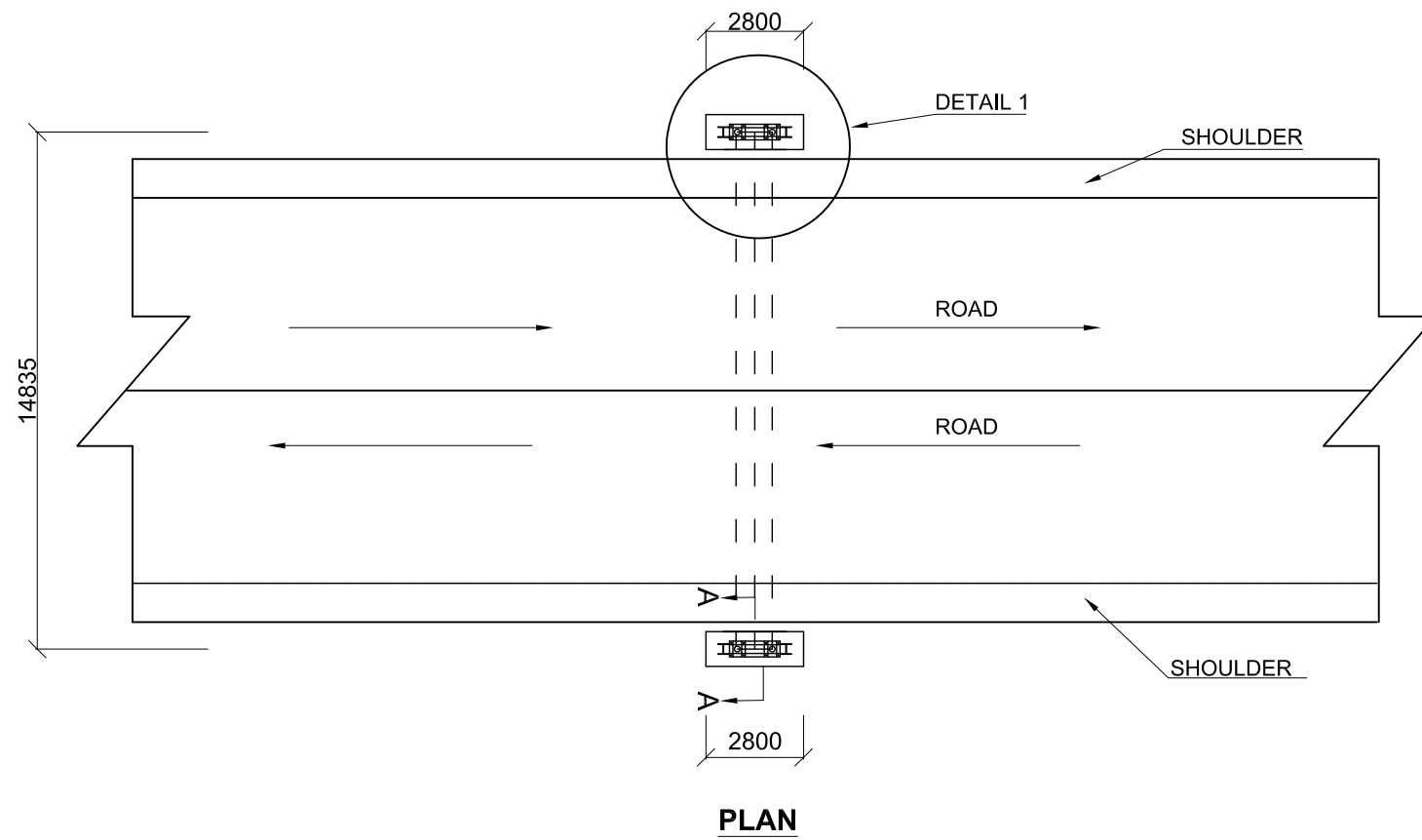

REINFORCEMENT DETAIL

	Recommended by	Approved by	SHEET. NO.
Signature	<i>[Signature]</i>	<i>[Signature]</i>	49
	Arjun Jung Thapa	Devendra Karli	
Designation	Deputy Director General	Director General	

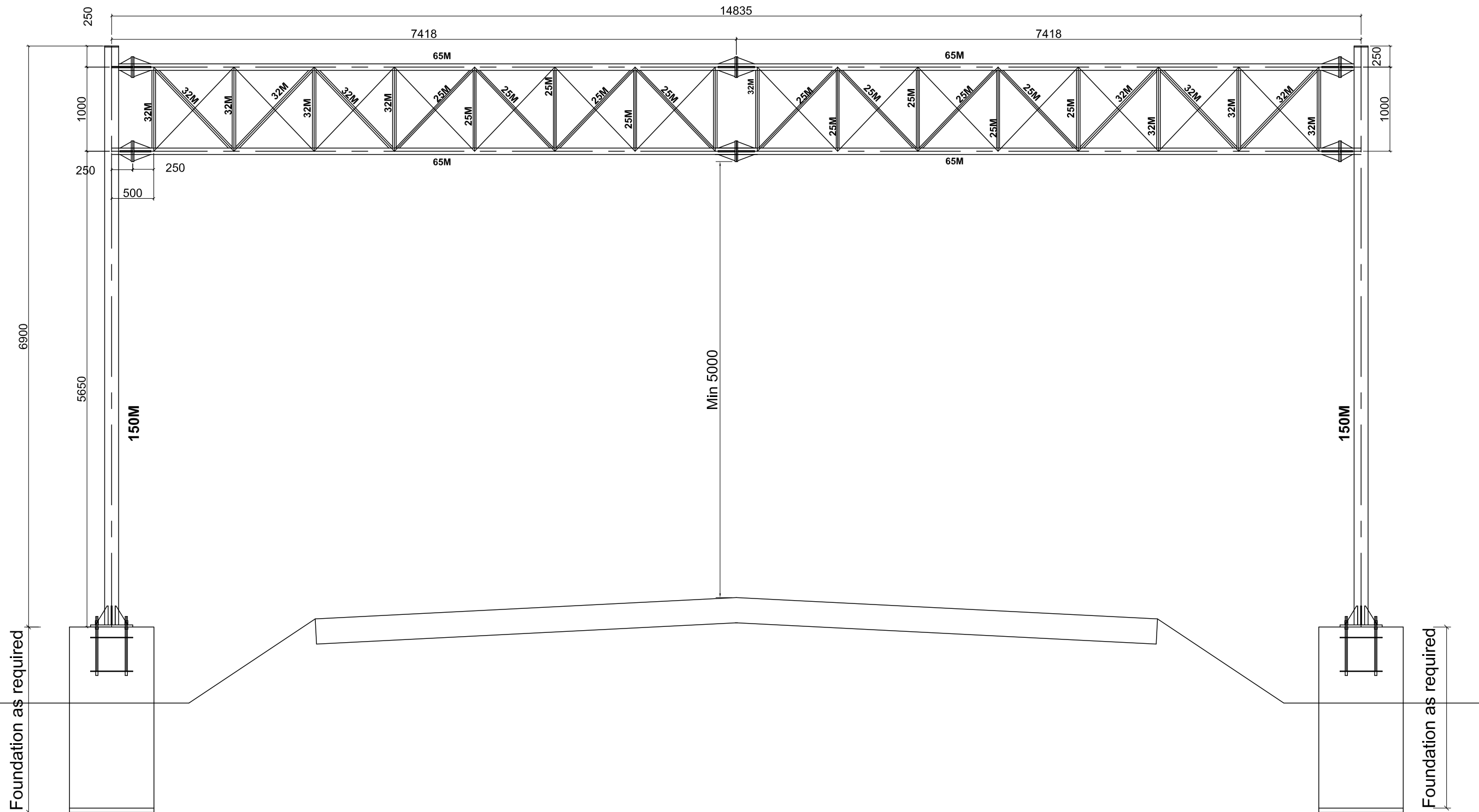

 Government of Nepal Ministry of Physical Infrastructure & Transport Department of Roads			
STANDARD DRAWINGS FOR ROAD ELEMENTS			
OVERHEAD TRAFFIC SIGN			
PLAN			
	Recommended by	Approved by	SHEET. NO.
Signature			50
	Arjun Jung Thapa	Devendra Karki	
Designation	Deputy Director General	Director General	



 Government of Nepal Ministry of Physical Infrastructure & Transport Department of Roads			
STANDARD DRAWINGS FOR ROAD ELEMENTS			
OVERHEAD TRAFFIC SIGN			
FRONT VIEW			
	Recommended by	Approved by	
Signature			SHEET. NO. 51
	Arjun Jung Thapa	Devendra Karki	
Designation	Deputy Director General	Director General	

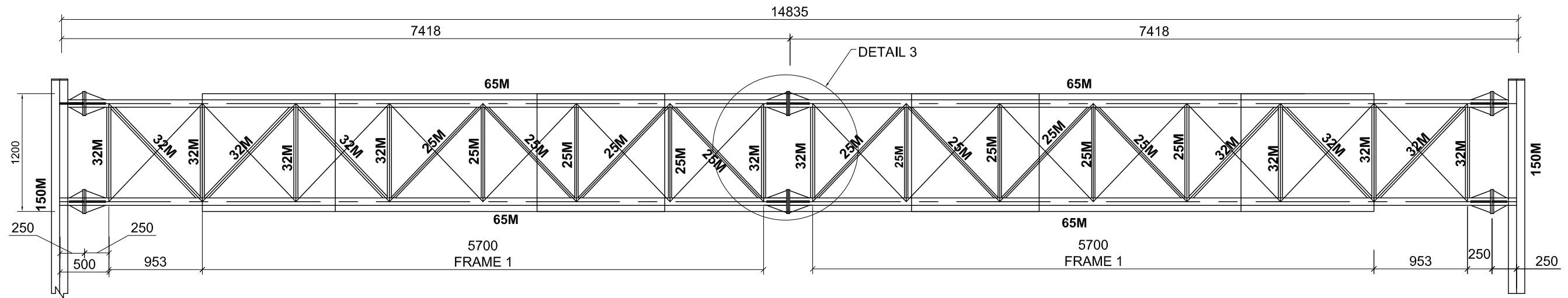

**FRONT VIEW
BEAM DETAILS**

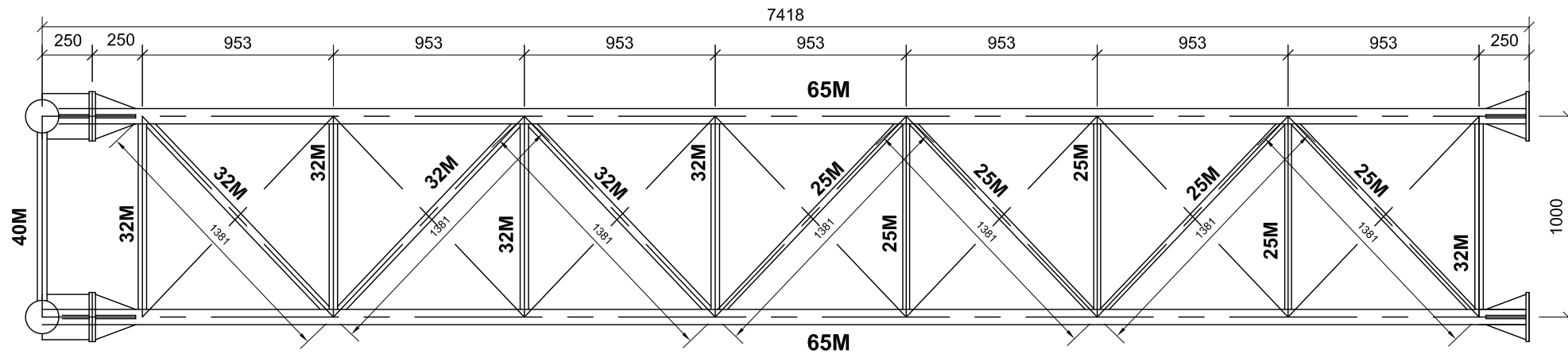

**HALF LONGITUDINAL
TOP VIEW OF GIRDER**

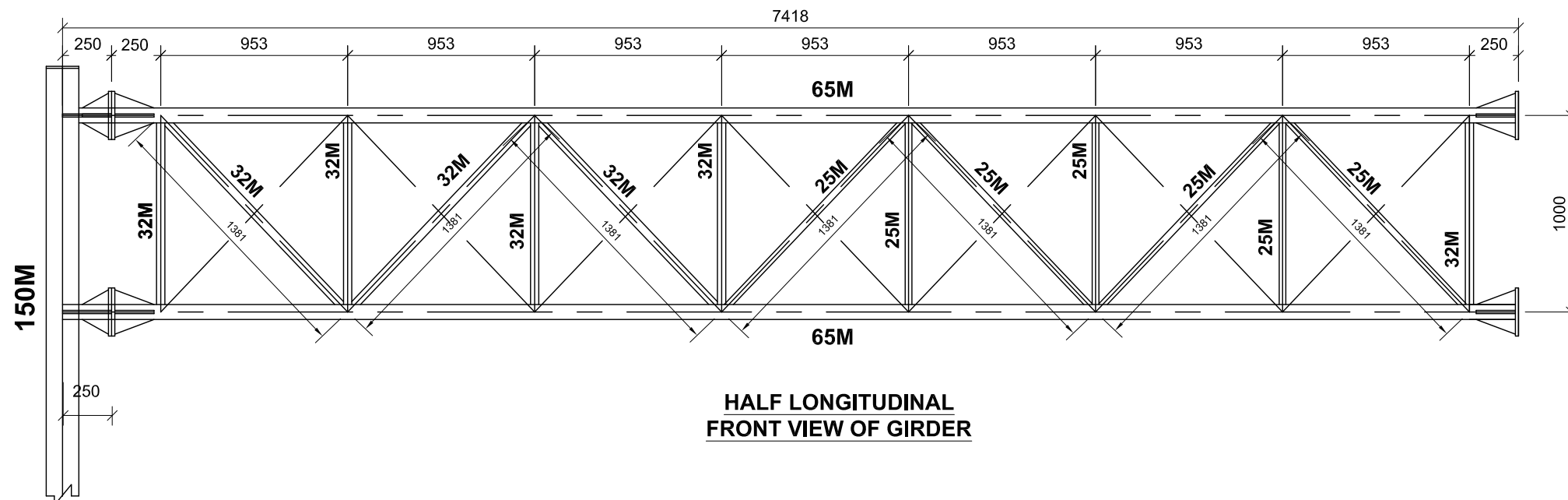

**HALF LONGITUDINAL
FRONT VIEW OF GIRDER**

 Government of Nepal Ministry of Physical Infrastructure & Transport Department of Roads			
STANDARD DRAWINGS FOR ROAD ELEMENTS			
OVEHEAD TRAFFIC SIGN			
GIRDER DETAILS			
	Recommended by	Approved by	SHEET. NO. 52
Signature			
	Arjun Jung Thapa	Devendra Karki	
Designation	Deputy Director General	Director General	

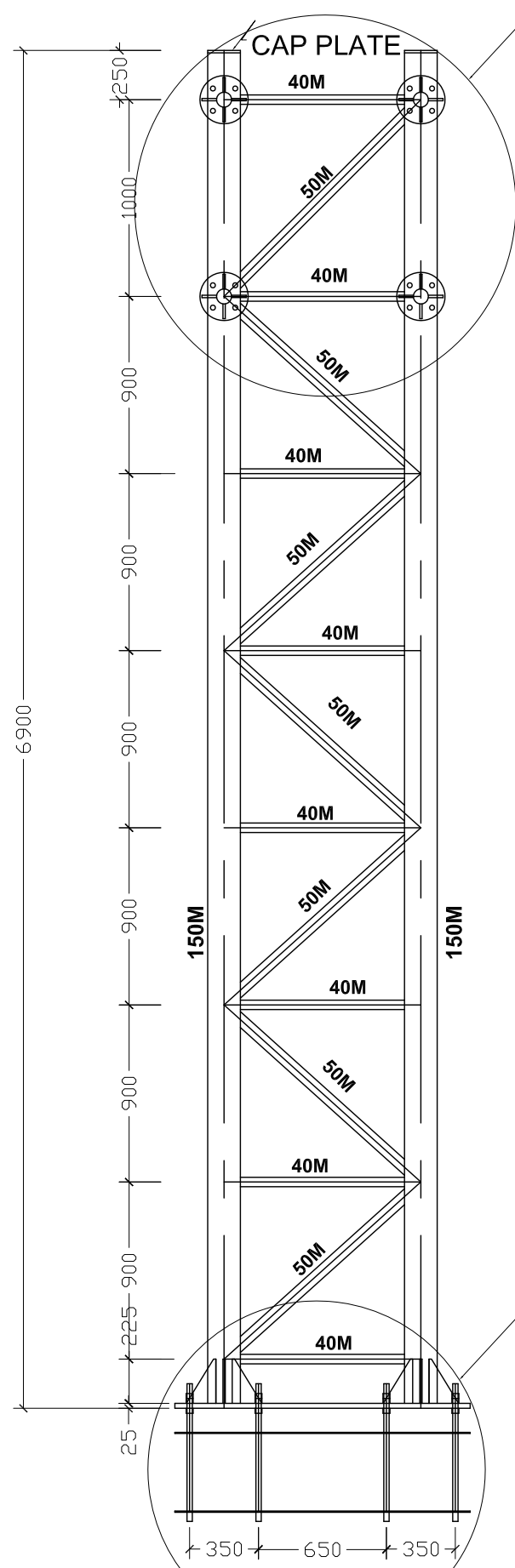

DETAIL 2

DETAIL 1

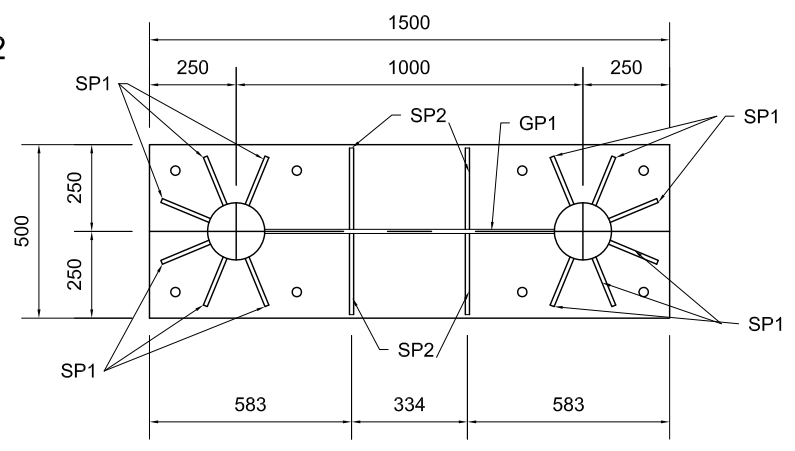

SECTION A-A

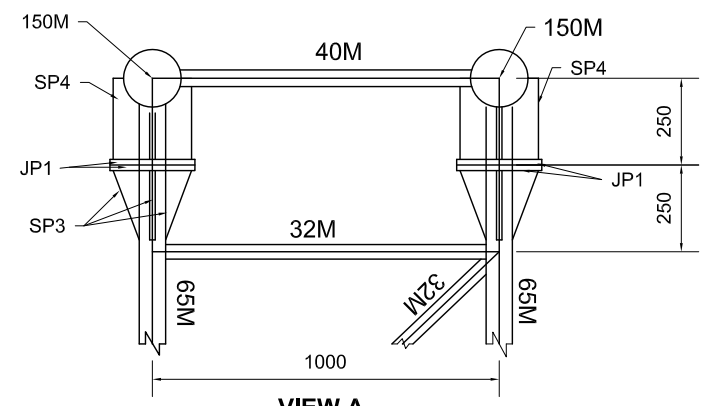

VIEW A

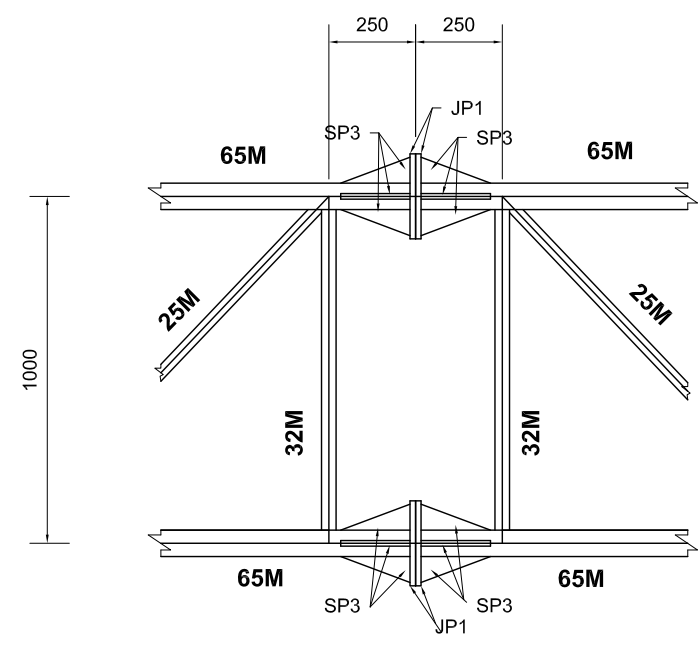

DETAIL AT 3

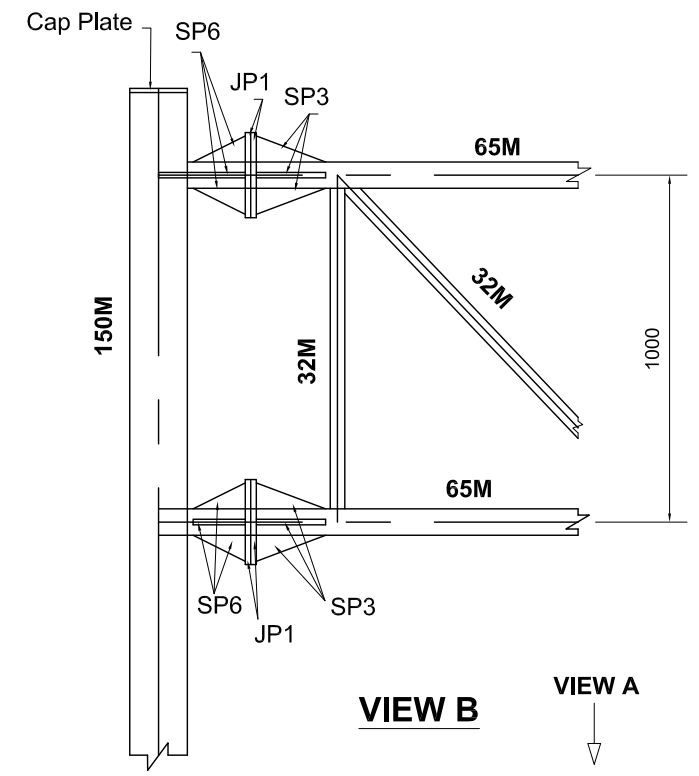

VIEW B

VIEW A

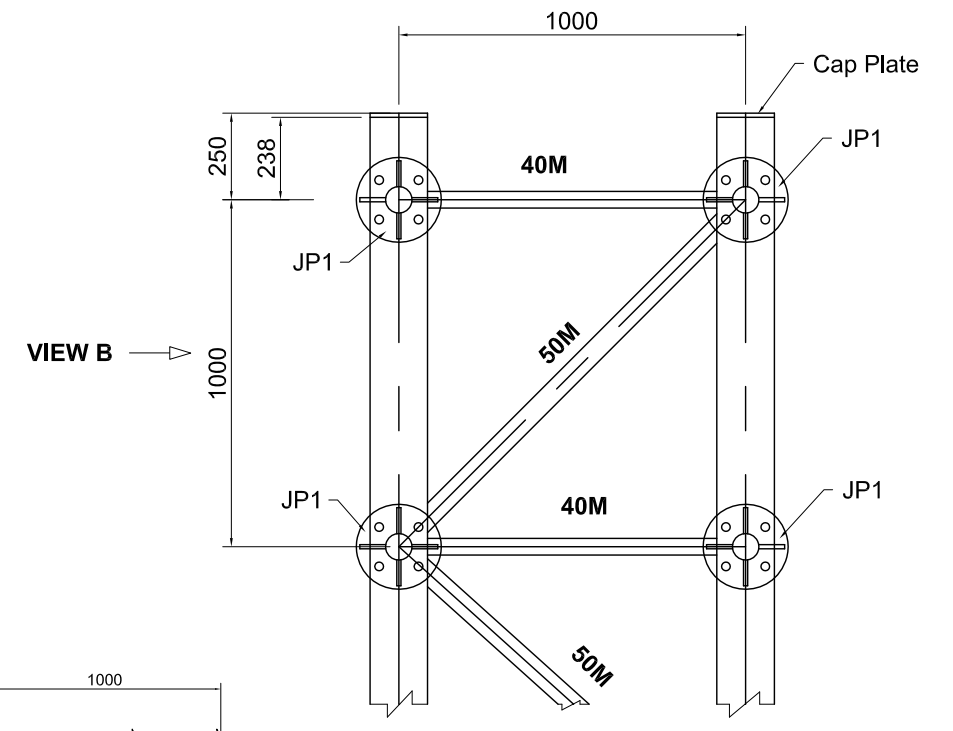

DETAIL AT 2

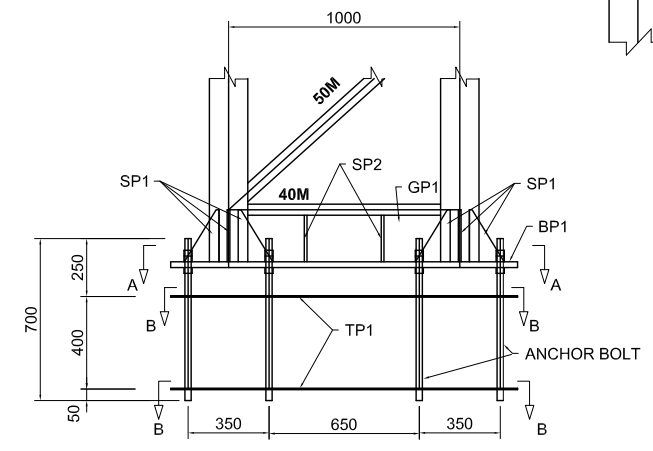

DETAIL AT 1

Government of Nepal Ministry of Physical Infrastructure & Transport Department of Roads			
STANDARD DRAWINGS FOR ROAD ELEMENTS			
OVERHEAD TRAFFIC SIGN			
SECTION DETAILS			
	Recommended by	Approved by	SHEET. NO. 53
Signature			
Designation	Deputy Director General	Director General	

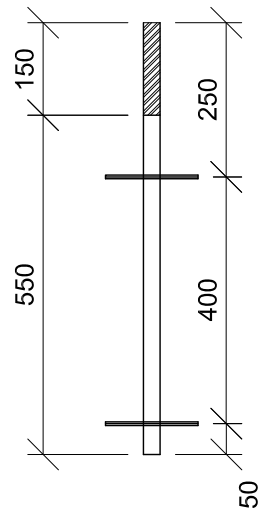

Anchor Bolt
Dia 25mm
(16 Nos)

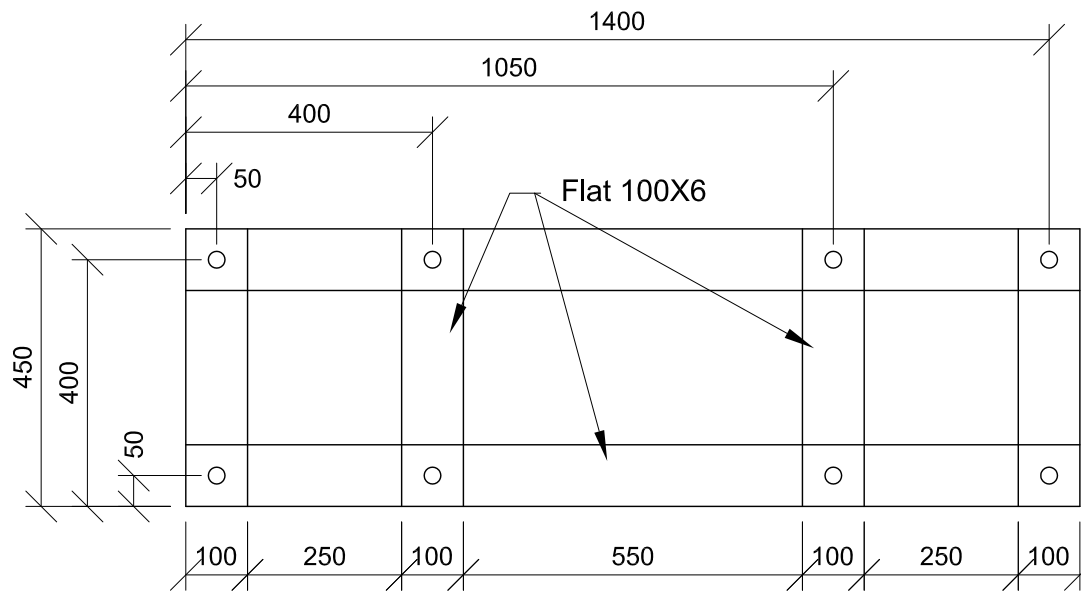

SECTION B-B
TP1 (4 nos.)

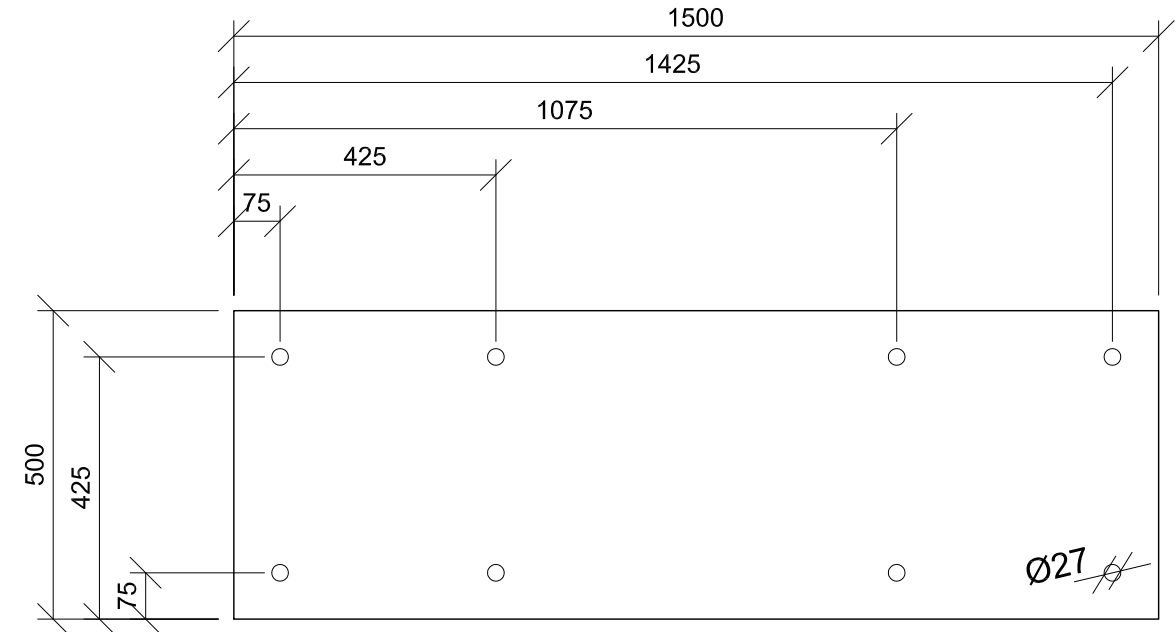

BP1 (25mm thick)
(2 nos.)

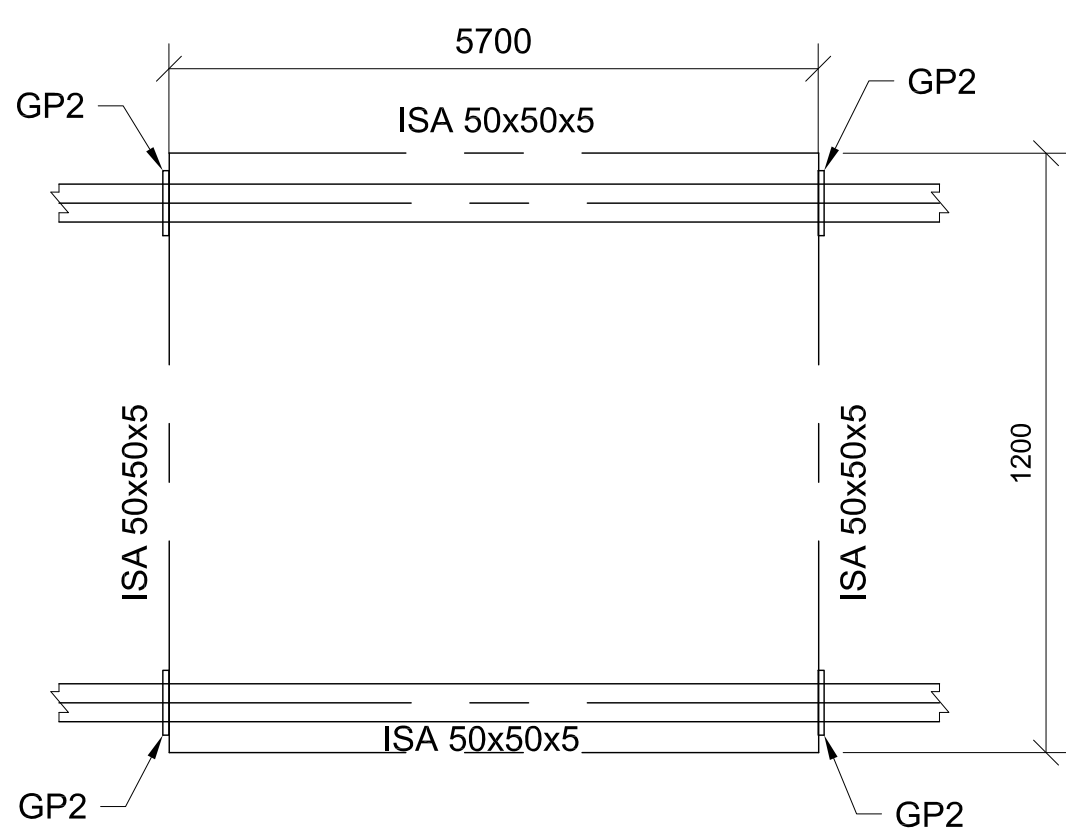

FRAME 1

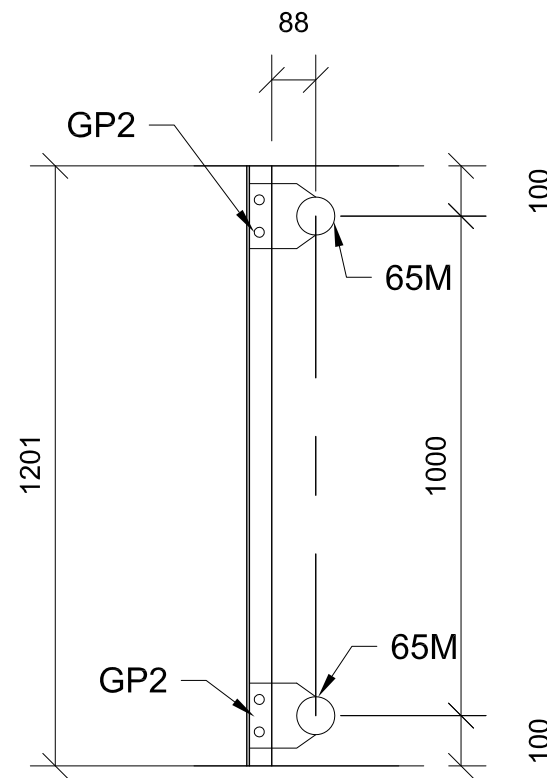

SECTION C-C

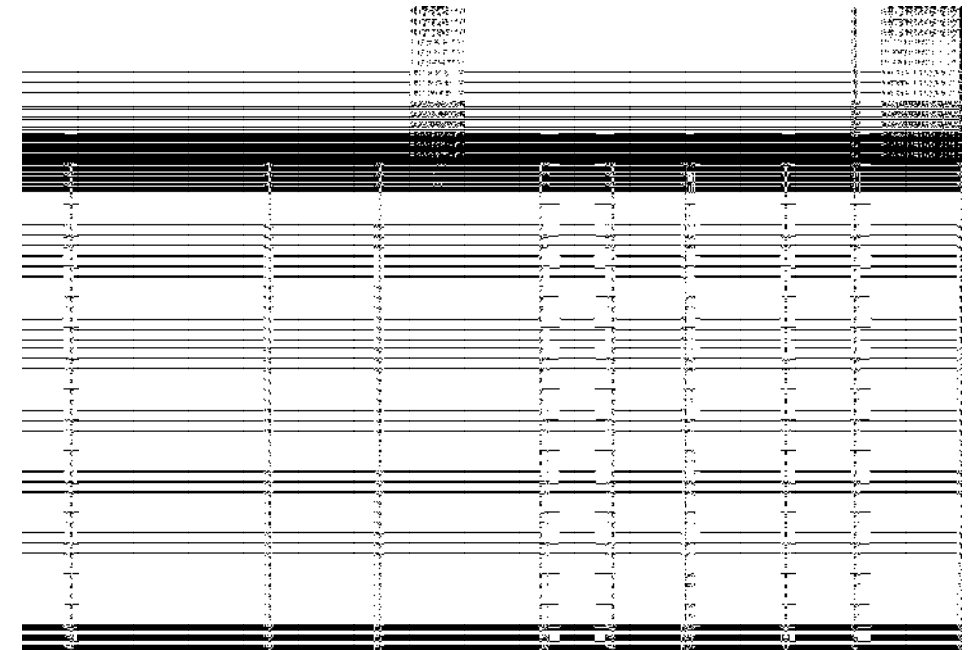

Government of Nepal Ministry of Physical Infrastructure & Transport Department of Roads			
STANDARD DRAWINGS FOR ROAD ELEMENTS			
OVERHEAD TRAFFIC SIGN			
ADDITIONAL DETAILS			
	Recommended by	Approved by	SHEET. NO. 54
Signature			
	Arjun Jung Thapa	Devendra Karki	
Designation	Deputy Director General	Director General	

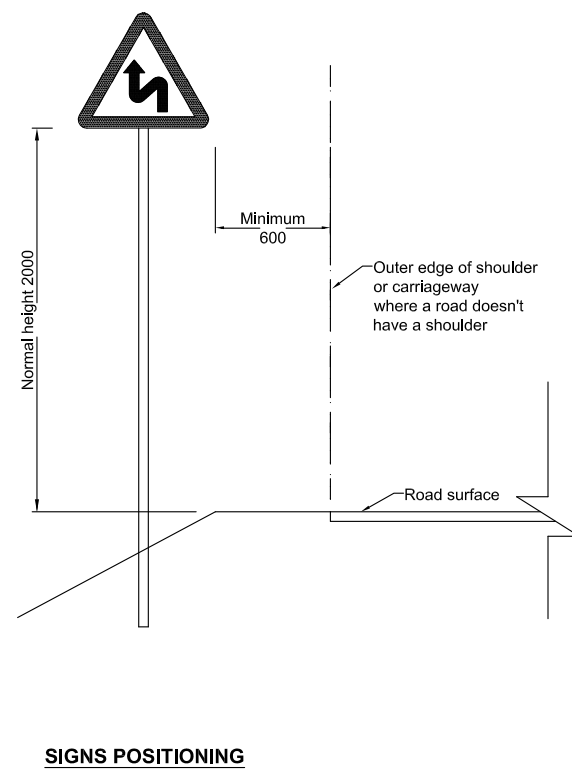
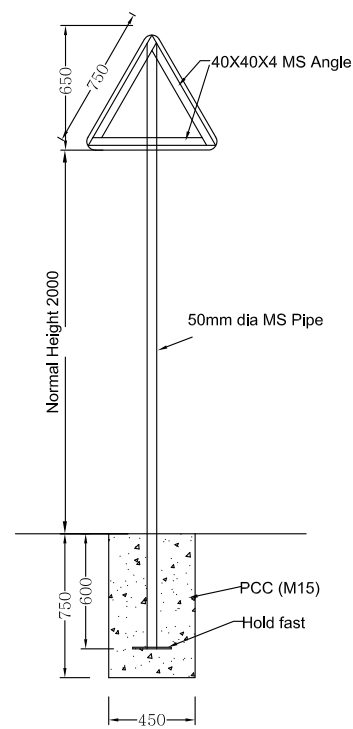
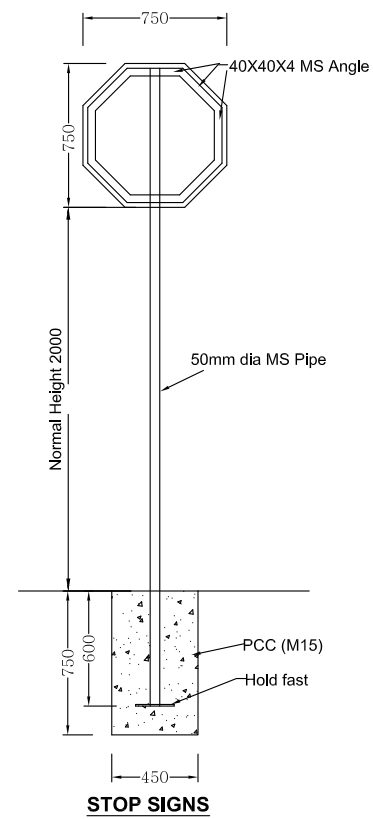
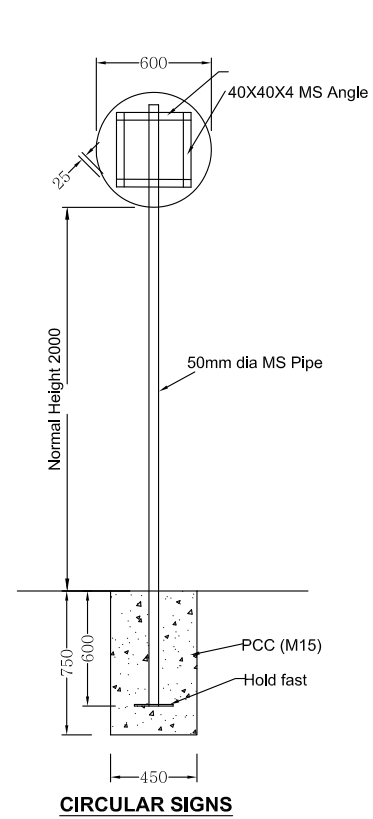

Note: For the dimensions of board signs and letter, please refer Traffic Signs Manual Vol 1 & 2

Government of Nepal Ministry of Physical Infrastructure & Transport Department of Roads			
STANDARD DRAWINGS FOR ROAD ELEMENTS			
ROAD TRAFFIC SIGNS			
TYPICAL DRAWING			
Signature	Recommended by	Approved by	SHEET. NO. 55
Designation	Deputy Director General	Director General	

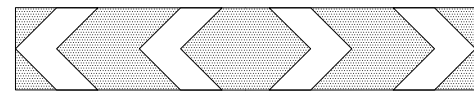

T-JUNCTION (TURN RIGHT OR LEFT ONLY)



DAANGEROUS OBSTRUCTION

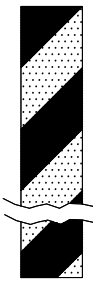

DAANGEROUS OBSTRUCTION

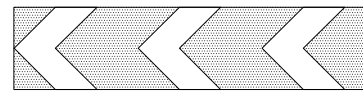
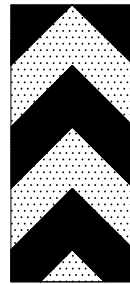

SHARP BEND (TEMPORARY DIVERSION)



TEMPORARY DIVERSION AHEAD

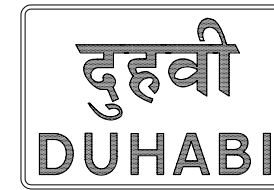

PLACE IDENTIFICATION SIGN (ENTRY TO BUILT-UP AREA)

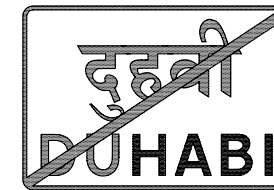

EXIT FROM BUILT-UP AREA

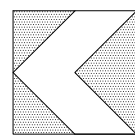
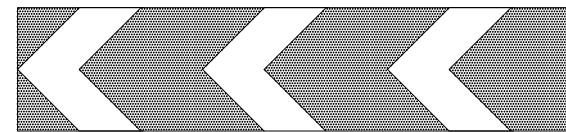

SHARP LEFT HAND BEND (RIGHT IF SIGN REVERSED)

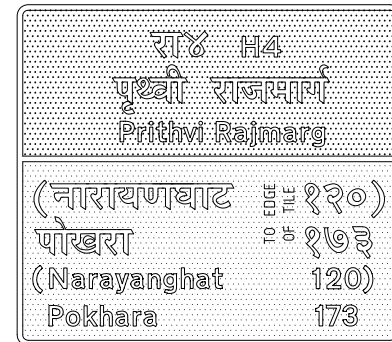

ROUTE CONFIRMATION SIGN-AFTER JUNCTIONS

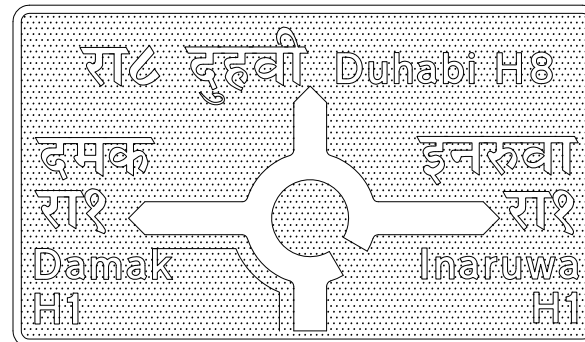

ON APPROACH TO JUNCTION

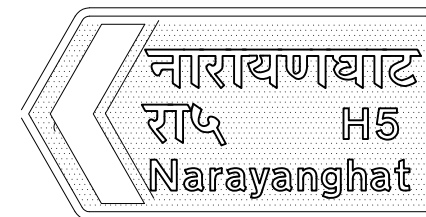

AT THE JUNCTION



TEMPORARY DIRECTION SIGN (DIVERSIONS)

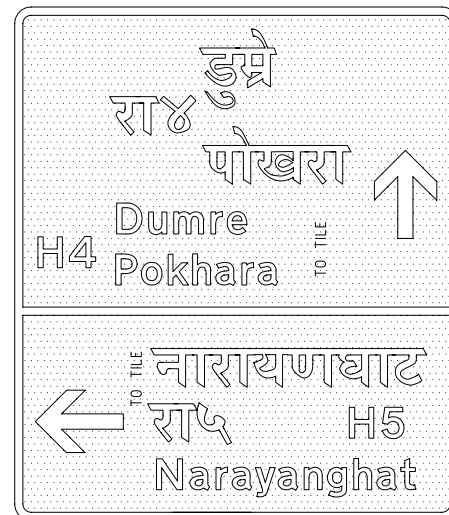

ON APPROACHES TO JUNCTION- (ALTERNATIVE)

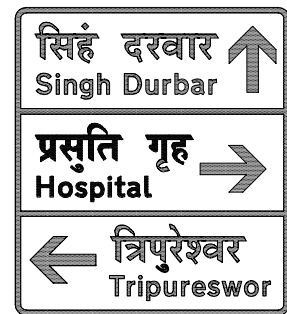

ON APPROACHES TO JUNCTIONS



BRIDGE NAME PLATE



TEMPORARY DIVERSION AHEAD

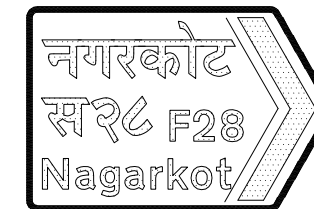

AT THE JUNCTION



D1 DISTANCE TO HAZARD D2 DISTANCE OVER WHICH HAZARD EXTENDS



D3 SCHOOL D4 EXCEPT BUSES



D5 FLOODING D6 SINGLE TRACK ROAD

SUPPLEMENTARY PLATES



D7 STOP D8 GIVE WAY



D9 SINGLE TRACK BRIDGE D10 ROAD CLOSED



D11 ACCIDENT D12 ICE

SUPPLEMENTARY PLATES



D13 ONE WAY D14 DUAL CARRIAGEWAY



D15 EXCEPT FOR ACCESS



D16 TIME PERIOD



D17 CAR D18 TRUCK

SUPPLEMENTARY PLATES WHITE BLACK



D19 BUS

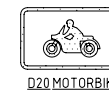

D20 MOTORBIKE



D21 TEMPO



D22 PEDAL CYCLE



D23 RICKSHAW



D24 ARROW TO THE RIGHT (ARROW MAY BE REVERSED)



D25 END



D26 END OF RESTRICTION

SUPPLEMENTARY PLATES WHITE BLACK

Note: For the dimensions of board signs and letter, please refer Traffic Signs Manual Vol 1 & 2

Government of Nepal Ministry of Physical Infrastructure & Transport Department of Roads			
STANDARD DRAWINGS FOR ROAD ELEMENTS			
ROAD TRAFFIC SIGNS			
TYPICAL DRAWINGS			
Signature	Recommended by	Approved by	SHEET. NO. 56
Designation	Deputy Director General	Director General	